



National *RADIO* News

Vol. 6—No. 6

WASHINGTON, D. C.

Feb.-Mar. 1935

IN THIS ISSUE

Newark's Police Radio

Auto Radio Battery and
Antenna Chart

Selecting and Connecting
Suitable P.A. Systems

Marine Radio

Alumni Association
Election Results
Etc.

Full Index, Page 30

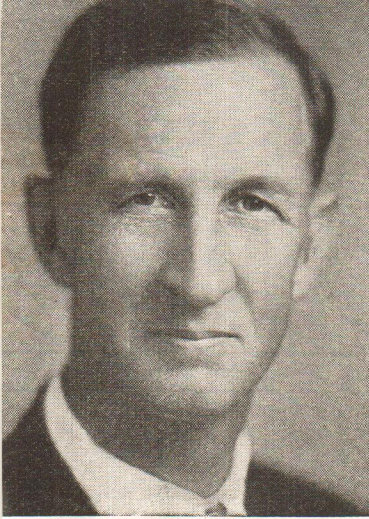

The President's Page

By J. E. Smith, President, N. R. I.

Airway Distress Waves

FOR years now it has been the practice of ships to have a Radio receiving set constantly tuned in on the distress calling frequency, 600 meters (500 kilocycles). Now, all Radio stations of the vast airway network of the Department of Commerce will be required to maintain a constant watch on the 96.5 meter and (3105 kilocycles).

When an SOS is flashed, it is the law of the sea that all other Radio traffic on that wave stops so that contact can be maintained with the vessel in distress. The reservation of the 3105 kilocycles channel will do the same for aerial navigation that the 500 kilocycle channel does for maritime navigation.

The Federal Airway Radio Service will cooperate with the private transport lines and their stations in establishing and maintaining this new service.

It is contemplated that all two way plane to ground communication with airway Radio stations will be conducted on the 3105 kilocycle as soon as all aircraft are equipped to use this national calling frequency. The plan is to have ground personnel follow all communications involving aircraft in flight over their particular sectors of the airway, so they can follow the progress of the flight and anticipate the requirements of pilots as to weather information and ground service.

— n r i —

Trade Optimistic

According to the trade reports that are being received from all localities, 1935 should offer

Page Two

exactly 365 happy days to the qualified Radio man.

That we have definitely withdrawn from the depression, is indicated by the anticipation of the Radio industry of a year which will exceed anything we have encountered since Radio's 1929-30 peak of nearly one billion dollars in retail trade.

The trend of Radio receivers of the 1934-35 model is for more refinement, higher price, greater ease of tuning and filtering out of extraneous noises. We are getting away from the cheaper midgets. We are going in for better Radios, for better reception, which seems to be what the ultimate purchasers desire.

Of course, since eighteen million homes are already equipped with Radios, the set makers can hardly expect to equal their peak year in 1935. But they, nevertheless, see tremendous gains ahead in replacements with these superior sets, the usual run of new installations, and the ever increasing strides in the sale of automobile Radios.

With eighteen million Radios to be serviced; nearly a billion dollar year of new sales in the offing, with higher priced receivers coming on the market (for service on which owners will be willing to pay larger fees) there is every reason for the trade to be optimistic—there is every reason for us to say there are happy days ahead for the qualified Radio-Trician.

— n r i —

A Correction

Due to an oversight of the proofreader, there was an error in Mr. Smith's page in the December-January issue of NATIONAL RADIO NEWS. A statement on this page read, "... as the Radio Industry of today gives employment to about 150,000 people." This should have read, "... as the *Manufacturing and Distribution branch* of the Radio Industry of today gives employment to about 150,000 people."—EDITOR.

— n r i —

Seasonable Felicitations

A University student who reached an examination question, "What causes a depression," wrote, "God knows! I don't! Merry Christmas!"

When the examination paper came back he found the professor's notation, "God gets 100. You get zero. Happy New Year!"

Newark's New Police Radio

THE tip of a flag pole serving as an antenna, hollow wires which, like water pipes, carry electricity without leaking, a quartz crystal scarcely thicker than a hair which acts as a control by vibrating 5,000,000 times a second, and operation in a wave band so remote from atmospheric disturbance that a bolt of lightning would cause only a barely audible click, are among the features of the Radio system which has just been placed in operation by the Police Department of the City of Newark.

The system operates on 30,100 kilocycles, an ultra-high frequency, being within a new frequency band tentatively assigned for police Radio work by the Federal Communications Commission. This frequency is about 20 times higher than the medium frequency band regularly assigned for police work and which is used by most police Radio systems now in operation. So popular has Radio proved for police service that in certain sections of the country few channels in the medium frequency band remain unassigned. Hence the Commission's decision to open up new frequencies for this service.

Operation on an ultra-high frequency, as embodied in the Newark system, possesses advantages for municipal stations. Freedom from atmospheric disturbance is one. Newark motor patrolmen listening to their receivers will not be troubled by static, thunderstorms or other types of interference which are ordinarily picked up by receivers in the medium frequency bands.

As the wave length to be used determines the length of the antenna, the extremely short waves used in the ultra-high frequency system mean proportionately shorter antennas. In the Newark system a short upper section of the 100 foot flag pole on the National Newark & Essex Bank Building serves as a very efficient antenna. To operate in the medium wave a longer antenna is necessary. The shortness of the antenna makes possible construction of transmitters which are mobile. Should Newark authorities at any time decide to establish two-way Radio service, transmitters could be installed in police cars, thus enabling the motor patrolmen to talk to headquarters as well as receive.

Ultra-high frequency waves have characteristics which prevent their being picked up over as great distances as can longer waves and consequently broadcasts made over ultra-high frequency systems confine themselves to smaller areas. A city as near as Albany, for instance, could probably use the same frequency as New-

(Page 18, please)

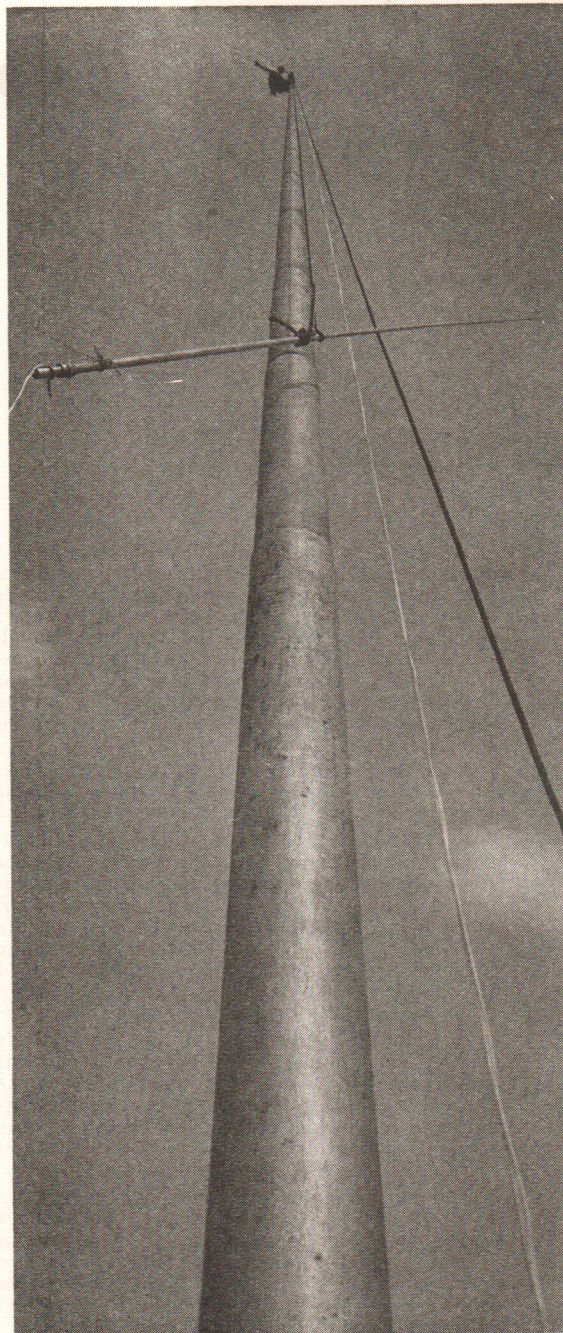

Steplejack erecting antenna of Newark Police Radio. 22 foot brass tube is being installed on top of 100 foot flag-pole. Antenna tube is 600 feet above ground.

Page Three



E. R. Haas,
Vice-President and
Director

Too Many Irons in the Fire

A few days ago a friend of mine, who is a Radio dealer, dropped into my office to discuss and get my opinion on some plans he has for the coming year. He has done fairly well in his Radio store and made the statement that he could probably increase his business, and consequently his earnings, by taking on additional lines of receivers—enabling him to offer a wider choice and price range to his prospective customers.

This brings up a problem which has been placed before me any number of times—"Should a dealer sell one or several makes of Radios?"

At first glance a person would naturally assume that the more lines of receivers you had, the more money you could make, and any number of Radio dealers operate as a result of this "first glance." But to get to the real meat of the subject, we must go below the surface—we must realize that there are a number of problems which enter into the matter and which must be carefully considered.

If a Radio dealer has a limited capital—let us say less than \$15,000—he should certainly stock and sell only one make of receiver. On the other hand, if he has more available capital, it often means that he should stock other lines of sets in order to use his capital to good advantage—keep it working for him.

The small dealer—the man with less than \$15,000 capital—should select what he considers is the best receiver made, and the best selling receiver in the price range that appeals most to his customers. He must himself become thoroughly sold on this receiver and then push it to his customers as hard as possible.

There is no doubt that the man handling only one line of receivers does lose an occasional sale because he does not carry the various competing makes, and this provides a strong temp-

Page Four

tation to add competitive lines. But usually the solution of this problem may be reached—not by investing heavily in the competitive product, but more thoroughly developing his sales force and his sales arguments with regard to the one receiver he is carrying.

I have known dealers who added competitive lines and immediately began to close more sales. But when the balance sheet was struck at the end of the accounting period, they found that their profits had *decreased*. What is the cause of this?

Well—the more capital they have tied up, the smaller rate of turnover they will have on their receivers. The more sets they have on display, means more floor space necessary, and consequently, greater rent, greater overhead, greater stock room space, greater personnel in the stock room, office, and sales room.

Then, there is an old sales principle which is violated when a dealer is handling more than one line of Radios—that is, the customer is confused—is doubtful as to which set to purchase—after seeing both or several. And we must also consider the additional time required to demonstrate two receivers, which is an additional overhead.

I have also found that in a sales organization, the individual salesmen will have their preferences. The individual salesman cannot become as sold on each of two makes as he can on one. He will usually push the line on which he is most sold and the greater volume of business will usually be on one line, rather than split between several lines. This means that the turnover on the added lines is far below what it should be, and finally represents a lot of frozen capital.

It must be remembered that in Radio selling, just like in any other kind of selling, it is not your gross sales figure which reflects the amount of profit. There are many organizations doing hundreds of thousands of dollars worth of business, and not making as much net profit as other organizations which are grossing much less. It is not just sales that you are after—it is *sales at a profit*, which should be the motto of every live merchandiser. What if you do lose an occasional sale? Could the profit on that sale and a few others like it compensate for the carrying of additional lines at much greater expense? Most likely the answer is "No"—so then, why lose money?

Now there are certain dealers who carry one

(Page 25, please)

The Service Forum

MAJESTIC TREASURE CHEST MODELS 380-381

OSCILLATION

If all parts are okay—no open condensers, etc., experiment with the position of the green wire connecting from the stator of the first tuning condenser to the coil. Also move the red and the white plus B and plate leads through the slit in the shield to the other tuning condenser compartment. Bringing these wires together causes regeneration and after a certain point, oscillation. Be sure that you have the regular antenna connected to the receiver when doing this so that you will not decrease the sensitivity too much.

— n r i —

GRUNOW MODELS 901, 701 & 801

INTERFERENCE FROM AIRPORT BEACON STATIONS

There are a number of ways of overcoming this trouble. One would be to choose a new I. F. frequency and align the I. F. amplifier at about 270 or about 255 kilocycles. This would call for realignment of the set oscillator and would probably upset the calibration somewhat. Another method is to obtain an old I. F. transformer designed for 260 or 262 kc. operation and place either the primary or the secondary in series with the antenna and the receiver antenna binding post. The trimmer across that section of the transformer should be adjusted until the interfering signals are cut out. This hook-up of course acts as a wave trap and may be used on other sets employing an I. F. frequency which is the same as the operating frequency of the interfering station.

— n r i —

GRUNOW MODELS 751, 752 & 750

TROUBLE WITH TUNING KNOB

Knob stays pulled out, and will not stay in when pushed in. The shaft which holds the knob goes into a brass coupling, which is on ball bearings. From the other end of the coupling protrudes the shaft on which is wound the dial cable. This shaft is held in the coupling by two set screws. The front or knob shaft has a slit. There is a corresponding slit in the coupling, and a steel pin goes through both while the knob shaft is pushed in. When handled roughly, the knob shaft pushes the dial cable shaft out a bit, in spite of set screws, making the two slits out of line. Loosen set screws and push cable shaft in until the two slits are lined up, then tighten screws. If this

doesn't help, bend pin so it will protrude into the slit more.

— n r i —

CROSLEY MODEL 148

NO RECEPTION

Check the intermediate frequency transformer tuning condenser located under the square hole cut in the chassis between the 58 type tubes. The mica sometimes punctures. Slip a new piece of mica under the hinge part of the condenser plate and realign. The other condensers located on top of the chassis should be checked for this difficulty.

— n r i —

CROSLEY MODEL 148

OSCILLATION

Try connecting a .02 microfarad 600 volt condenser from the chassis to the power transformer side of the A. C. switch.

— n r i —

CROSLEY MODEL 148

FADING

Use a 6.3 volt pilot light in those sets employing a 42 type tube—do not use a 2.5 volt pilot light as this will result in fading.

— n r i —

PHILCO MODELS 60 & 38

DIAL SLIPPING

This condition is often caused by too much tension on the nuts at the back of the drive shaft. The slipping can be eliminated by loosening the nuts slightly to allow the rotor to turn more freely.

— n r i —

PHILCO MODELS 89 & 19

OSCILLATOR CEASES TO WORK

This condition has been traced to an open of the oscillator bias resistor's bypass condenser. A .0007 microfarad condenser can be used for replacement purposes. In the later model using the type 77 detector oscillator this condenser has been increased in capacity to .0014 microfarads.

— n r i —

CROSLEY MODEL 130

OSCILLATION, LACK OF VOLUME OR HUM

Check for a defect in the 4 microfarad 300 volt section of the dual cardboard type dry electrolytic condenser. The condenser frequently opens. Use a 450 volt replacement condenser in this position.

(Page 9, please)

Page Five

AUTOMOBILE RADIO, BATTERY AND ANTENNA CHART

Those readers of National Radio News who are doing work on automobile Radios will find the following chart very handy. The information is for 1934 model automobiles only.

Make of Car	Models	Antenna Lead-in	Battery Grounded	Make of Cars	Models	Antenna Lead-in	Battery Grounded
Auburn	6-52 8-50	R. H. windshield pillar R. H. windshield pillar	Pos. Pos.	Lincoln	145 (closed models) 136 (closed models)	R. H. pillar post R. H. pillar post	Neg. Neg.
Buick	Series 50 Series 60 Series 90	Left front corner post Left front corner post Left front corner post	Neg. Neg. Neg.	Nash	1220 1280 1290	Left front door pillar Left front door pillar Left front door pillar	Pos. Pos. Pos.
Cadillac	"D" Series 355-V-8 370 V-12 452 V-16	L. H. front pillar installed on dash R. H. rear quarter for rear set installations	Radio Pos.	Oldsmobile	All models	Left front corner post	Neg.
Chevrolet	All closed models but Cabriolet	L. H. windshield pillar	Neg.	Packard	1100 1101 1102 1103 1104 1105 1106 1107 1108	Right front pillar Right front pillar Right front pillar Right front pillar Right front pillar Right front pillar Right front pillar Right front pillar Right front pillar	Pos. Pos. Pos. Pos. Pos. Pos. Pos. Pos. Pos.
Chrysler	PE PF Special DR DS DT SE CY CA CU CV CW	Right "A" pillar Right "A" pillar Right "A" pillar Right "A" pillar Right "A" pillar Right floorboard Right floorboard Right "A" pillar Right floorboard Right floorboard Right floorboard	Pos. Pos. Pos. Pos. Pos. Pos. Pos. Pos. Pos. Pos. Pos.	Pierce-Arrow	S36-A 840-A 1240-A 1248-A	Right front door windlace Right front door windlace Right front door windlace Right front door windlace	Pos. Pos. Pos. Pos.
Dodge	All (closed models)	Right "A" post	Pos.	Later production 1934 models have lead-in down left front door windlace.			
Ford	40 (closed models)	R. H. front pillar	Pos.	Plymouth	Closed models	Right "A" Post	Pos.
Graham	67 68 69	Left front pillar Left front pillar Left front pillar	Pos. Pos. Pos.	Pontiac	All models	Left pillar No. 1	Neg.
Hudson	All models	Left front pillar	Pos.	Reo	S-4	R. H. windshield post	Neg.
Hupmobile	421-J 427-T 417-W	Right front pillar Right front pillar Left front pillar	Pos. Pos. Pos.	Studebaker	A B C	Left front pillar Left front pillar Left front pillar	Pos. Pos. Pos.
Lafayette	110	Left front door pillar	Pos.	Terraplane	All models	Left windshield pillar	Pos.
La Salle	345	L. H. front pillar	Pos.	Willys-Overland	77	None supplied	Neg.

Easy Measurement Charts

Simple Formulas And Charts For Determining Wattage Rating Of Resistors

IN the last edition of NATIONAL RADIO NEWS the Radio student was introduced to the primary considerations dealing with the flow of current in conductors. Ohm's Law was treated in its elementary form using simple formulas and easy reading charts.

It is very necessary, to get a thorough understanding of Radio, that the student learn to handle these three units, the volt, ampere and ohm, and become thoroughly familiar with their significance when dealing with Radio and electrical circuits.

It is the purpose of this article to go somewhat more deeply into detail regarding the resistance factor of Ohm's Law, inasmuch as resistance is probably the most important item in any circuit.

When making resistor calculations, two fundamental formulas are employed. One, known as Ohm's Law, shows the relation between voltage, current and resistance in the circuit while the wattage formula gives the power consumed in the circuit.

In Radio and electrical circuits it is not suf-

J. A. Dowie,
N. R. I. Chief
Instructor

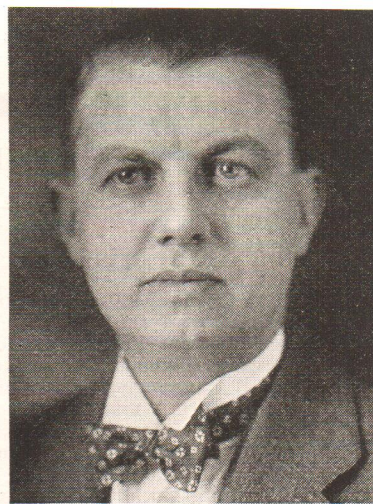

ficient to know that, for a given purpose a resistor of a certain value in ohms must be used. We must also know what wattage rating the resistor must have, in order to carry safely the required current. The wattage may be easily determined from the following simple formulas or charts shown in figures 1 and 2.

- (1) Watts (power) = Volts \times Amperes
- (2) Watts (power) = Current² \times Resistance
- (3) Watts (power) = Volts² \div Resistance

By working out a few examples using the above simple formulas and the charts will illustrate the usefulness of them.

Examples: Suppose the voltage across a 5 ohm resistor is 5 volts and the current 1 ampere. What wattage is the resistor dissipating?

- (1) $W = V \times A = 5 \times 1$ or 5 watts.
- (2) $W = I^2 \times R = 1 \times 1 \times 5$ or 5 watts.
- (3) $W = V^2 \div R = 5 \times 5 \div 5$ or 5 watts.

Another example, suppose the voltage across a 1 ohm resistor is 8½ (8.5) volts and the current is 8 amperes, the wattage dissipation is $8.5 \times 8 = 68$ watts.

Let us check these results with chart Figure 1. Draw a straight line with ruler and pencil between any of the two known values, volts, amperes or ohms, the point which intersects the watts scale, marks the value of the unknown in these examples 5 and 68 watts respectively.

A resistor has a voltage of 50 volts across its terminals and a current of 100 milliamperes is known to be flowing through the resistor. What wattage is this resistor dissipating? $W = E \times I = 50 \times .1 = 5$ watts. Suppose a current of 10 milliamperes is flowing through a resistor of 4000 ohms, what would be the wattage dissipation? $I^2 \times R = .01 \times .01 \times 4000 = .4$ watt.

A bias resistor for a vacuum tube has 40 volts across it. The resistance value is 2,000 ohms.

(Page 10, please)

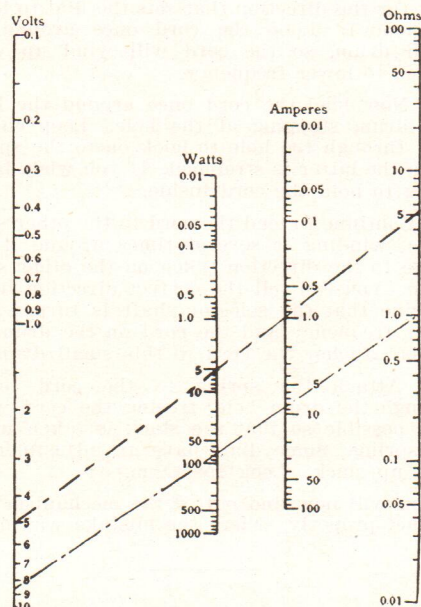

Fig. 1.

General Service Hints

By J. B. Straughn, N. R. I. Service Consultant



J. B. Straughn

How To Restring Selector Dial Cables

HAVE you ever tried to tune a receiver where a turn of the station selector did not produce an immediate action on the tuning condensers? If you have, you know how objectionable it can be, especially on distant stations. Every effort is made by the set designer to use a dial mechanism which has no back-lash. Even well made, cable driven, drum dials develop this defect; in fact, the cable sometimes breaks, making station adjustment impossible.

If the station selector acts stiff, lubricate the dial mechanisms and the bearings on the condenser. Should the control still bind, try aligning the condenser and dial mechanism.

Loose action or back-lash effect is probably due to a stretched cable, poor spring, stiff mechanism, or loose set screws. Remedies for this defect will be obvious, but I would like to say a few words about loose or stretched cables. When they are of the linen or fishing cord type I would wax the cable with beeswax; a wax with a little rosin in it is best. You can get this at a tailor shop. Then where the cord hooks on to the spring, I would tie the two ends into a knot farther up and rehook the cord. This will take up the slack and cause the spring to be stiffer.

When the cord breaks and you have enough cord to make a square knot at the break, do so. Should this be impractical, then you will have to buy a new cable.

You probably know that there are a large variety cable drive, in fact too many to consider, so I will have to take a typical case. It is always wise, where possible, to study the cable arrangement in a similar machine. Use this as a guide.

Now let's take a typical cable drive. The selector shaft has two small drums on which the ends of the cord are wound and tied. As the shaft is turned, the cord on one small drum

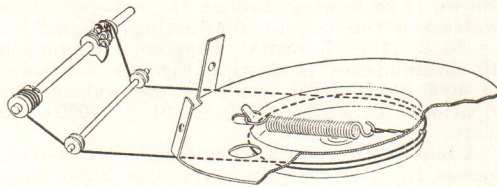

A typical drive cord arrangement

Page Eight

winds on, as the other winds off. As the cable moves, the grip it has on the drum valve causes the latter to turn and, of course, turns the variable condenser. If you bear in mind this general action your troubles in putting on a new cable will be greatly reduced.

Always take the radio chassis out of the cabinet, as this will simplify the work. If the cable has not come off entirely, study its assembly. Cables for the more popular receivers are available. Here are the usual steps that are taken.

1. Set the variable condenser at high frequency, condenser plate wide open, and hook the cable to the small drum that winds up as the selector shaft is turned in the clockwise direction (or the direction that sets the dial to lower frequency). Loop the cord once around the small drum, so the cord will wind up when turned to lower frequency.

2. Now lead the cord once around the large dial drum stopping at the hole. Loop enough of it through the hole to hook on to the spring, when the latter is stretched. If you wish, insert a peg to hold the cord inside.

3. Continue to lead the cord to the other small drum, winding it several times around it, opposite to the direction taken on the other small drum. You can tell the correct direction if you imagine that the selector shaft is turned to a lower frequency and the cord on the drum unwinds. Anchor the cord to this small drum.

4. Attach the spring to the cord looped through the drum hole, freeing the cord wherever possible so that the slack is taken up by the spring. Some dials have an adjustment to take up slack. Look for them.

You will now find out, if the mechanism does not act properly, where the mistake was made.

Graduates—join your alumni association.

Elevator Radio

Here's something new. So far as we know it remained for a young colored boy, the operator of an elevator in one of Washington's office buildings, to be the pioneer in elevator Radios.

He installed a small set on a shelf over the car controls and connected it to an antenna stretched across the roof of the car. He says that he put the Radio in his elevator to pep up the office workers as they came to work in the morning.

He has tried several different kinds of music, but finds that jazz is best for the early morning. He takes in his passengers at the ground floor with gloomy frowns on their faces and has them smiling by the time they reach their offices.

Although this young man gives "the smiles of his riders" as his reason for the elevator Radio, we have an idea that the Radio was put there chiefly because the elevator operator likes to listen to music as he goes about his day's work.

Regardless of the reason, however, there may be an idea in this for some wide-awake Radio men. Why not install small sets in office building elevators about town? Think it over.

— n r i —

Service Forum

(Continued from page 5)

**CROSLLEY
MODELS
53 & 54**

**OVERHEATING OR BURN-
OUT OF THE 1,650 OHM
BIAS RESISTOR OF THE
45 TYPE TUBE**

This is due to a break-down in the .5 mfd. condenser connected between the voice coil of the speaker and the filament end of the biasing resistor. A 600 volt replacement condenser can be employed.

— n r i —

**RCA VICTOR
MODEL M-34**

LOW GAIN

This may be caused by the antenna condenser being open or shorted. This condenser is not shown as such on a diagram of this circuit as it consists in the distributed capacity of two turns of wire around the second coil. There is another coupling of this type between the first two stages which must be in good shape for good gain of the receiver.

— n r i —

**RCA VICTOR
MODEL M-34**

INCREASING VOLUME

A 400,000 ohm resistor applied from the cathode of the 6A7 to the center tap of the (Page 22, please)

New CONTINENTAL Suppressor

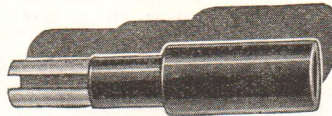

A new distributor suppressor, the CONTINENTAL Type T-13, with several new and distinctive features, has just been announced by Continental Carbon, Inc., 13900 Lorain Avenue, Cleveland, Ohio. In place of the older rating of 15,000 ohms, the Type T-13 has a standard resistance of 10,000 ohms. The new standard resistance operates satisfactorily without loss of suppressor efficiency.

A spring insert, molded into the bakelite housing of the suppressor, fits an eighth-inch below the top of the distributor well, thus minimizing high tension leakage. The insert is easily adjusted with a pair of pliers to fit any hole and with any desired spring tension.

A convenient screw terminal for the cable provides a waterproof joint. In addition the rubber cap, usually fitted around the high tension cable at the distributor sockets, may also be fitted around the Type T-13 Suppressor to further assure a waterproof connection with the cable.

— n r i —

Manson Publishing Company

The Manson Publishing Company of 521 Fifth Ave., New York City, is marketing three books entitled, "Broadcast Receiver Design," "All-Wave Receiver Design," and "High Fidelity Receiver Design."

These books are by Mr. G. S. Granger, recognized engineer and authority on Radio subjects—well known to the Radio serviceman for his articles which have appeared in many trade journals. He has prepared these three publications expressly for the serviceman, treating receiver design with a view towards thoroughly explaining the present type and those which will be marketed in the near future, so that the serviceman will be familiar with these sets when they come up for servicing.

The Manson Publishing Company offers these books for sale at fifty cents each, or the set of three for one dollar. Readers of NATIONAL RADIO NEWS who are interested in these publications should write to the Manson Publishing Company direct.

Page Nine

What wattage is the resistor dissipating? If the voltage and resistance are known, the wattage rating can be calculated for the formula (3) $W = V^2 \div R$. $40 \times 40 \div 2000 = 1600 \div 2000 = .8$ watt.

By knowing any two factors we do not necessarily have to use any formulas, all we have to do is to lay a ruler or straight-edge across the chart Fig. 2 from one known value to the other; the points at which this line, or its continuation intersects the other scales shows the other two values.

It should be understood that these formulas and charts only indicate the power in watts that is dissipated or used up in a resistor.

In practical Radio design, and when replacing resistors in a set it is quite customary to use resistors of a wattage rating about 50% to 75% greater than their maximum watts to be dissipated. This is done as a precaution against burn-outs where facilities for ventilation is poor.

It should be remembered that the heating of resistors, while chiefly due to the power dissipated in them, is also increased by their proximity to other warm parts or hot parts such as vacuum tubes and other resistors, and to lack of sufficient air circulation.

Therefore always add at least 50% to these figures to obtain a resistor that will give satisfactory service.

For example, suppose the current in the resistor is 20 milliamperes and that the resistor value is 4000 ohms. The current in amperes would be 20 milliamperes $\times .001 = .02$ of an ampere.

Now that we know the resistance in ohms and the current in amperes to be carried the voltage rating of the resistor using formula $W = I^2 \times R$ will be $.02 \times .02 = .0004 \times 4000 = 1.6$ watts.

It is obvious that a one watt resistor will not do. Even a two watt resistor would not be safe to use. A 3 or 5 watt resistor should be used. This is the usual practice.

Radio-Tricians will find many uses for these Wattage Formulas and charts in Radio work,

Page Ten

therefore it is advisable to preserve them for future reference.

I am mighty glad that these Easy Measurement Charts have met with such favor among the students and graduates of the National Radio Institute. Since the first one was published in the last issue of NATIONAL RADIO NEWS I have had a volume of favorable comments upon them. The fellows have asked that they be continued, and this I will do.

Also, I have received a number of letters asking if these charts could be supplied by the Institute. In various sizes and mounted on heavy material so that they would be more serviceable than in their present form in NATIONAL RADIO NEWS.

Due to the fact that each and every fellow who uses these charts has his own ideas about the size best fitted for his needs, it would be impossible to stock them here at the Institute.

But for those of you who would like to have them in a more permanent form, and in a different size, here is a suggestion: Take your copies of NATIONAL RADIO NEWS which contain the Charts

to a company which makes a business of making photostats. You'll probably find them listed in the phone book. Tell this company just what size you'd like to have them, and they will make up photostats of each chart, without damaging your NATIONAL RADIO NEWS in any way. The cost will not be very great. I imagine they can be made for about fifty cents each.

Then, when they are completed, mount them on canvas, heavy cardboard, or other material and they can be kept in your shop, office, workroom, or wherever you find them most convenient.

— n r i —

The Depression

Two darkies were talking about the depression. "Boy," said one, "what would you do if you had all de money in de worl' right now?"

"Well, suh," replied the other, "Ah reckon I'd pay hit on mah debts—fur as hit would go."

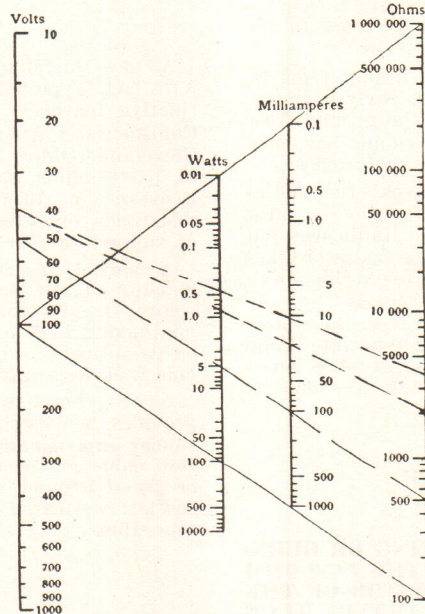
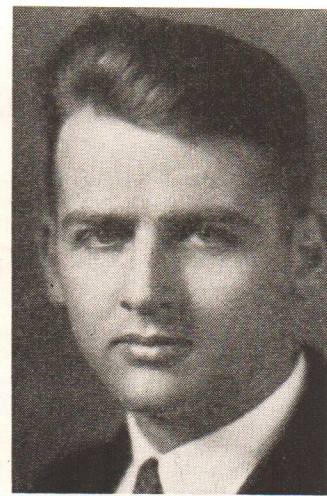

Fig. 2.

Selecting and Connecting Suitable Public Address Systems

By Paul Thomsen, N. R. I. Staff



THE selection of a suitable P. A. system always involves a careful study of what is needed. The environment, the audience, the space available for the equipment, type of power available, the audio quality and output power needed must all be expertly weighed. The general appearance of the equipment is important, for a makeshift assembly will discourage the customer. If the equipment is to be of a permanent character, ease of operation is a vital factor.

It is assumed that any reasonable Radio-Trician will consider manufactured equipment rather than assembling them from parts. It is good business to do this, because much time is necessary to assemble, install and maintain any P. A. System.

Generally speaking, all public address systems have an input, or pickup device, and output devices. The input pickup may consist of one or more microphones, a radio tuner or a phonograph pickup; or it may consist of a combination of these devices. Each of these pickups has its own characteristics; namely, that it will deliver at its output terminals A.F. energy at different levels. Furthermore, they will have different output impedances.

The output devices are without exception one or more loudspeakers because a public address system is a means of radiating sound energy at high levels.

Now let us take the pickup and output devices.

Pickup Devices. There are several types of microphones that have come into general use for public address systems. The two button carbon microphone has proven and still is the most popular type because it is relatively inexpensive, easily handled and has greater output in comparison to the other microphones.

Then, too, there are the crystal, condenser and inductor microphones which have less output but have more favorable quality characteristics.

Perhaps the most used high fidelity microphone at the present time is the velocity microphone which has a directional characteristic. That is, sound in certain directions only can be picked up. This is of particular advantage where there is a possibility of feedback from the loudspeaker to the microphone. All other microphones are considered non-directional. That is, they pick up sound energy from a wide angle.

Radio tuners are extensively used as pickups in public address systems. Any selective re-

ceiver having a power detector and perhaps one stage of audio amplification is suitable. The tuner is generally used to pickup local or semi-distant stations, as any P.A. system must reproduce quality rather than distance.

It is almost a universal practice to include a phonograph pickup unit in any public address system, as it has the commercial and practical advantages of being able to supply entertainment or attention getting material while talks are not projected to the audience. The most popular type of pickup is the magnetic type. Of course, with the pickup there should be an electrical turntable.

Reproducer Units. The moving coil reproducer is the most popular in the public address field. It may actuate a cone, the low frequencies reinforced by a flat or directional baffle; or the moving coil unit may move the mass of air by the use of a cone coupling. These are respectively referred to as dynamic speakers or horn dynamics or trumpet speakers. The trumpet speaker is particularly valuable where directive radiation of sound is desired.

The same is true to a lesser degree for directive baffles used with cone type speakers. The flat baffle cone dynamic is for general broad radiation of sound.

These speakers have a general overall frequency characteristic limited to a low of 60 to 120 cycles per second and an upper limit of approximately 4,000 to 5,000 cycles per second. To reinforce the higher frequencies, that is, to extend the frequency range of a P.A. system, the tweeter speaker which may be of the moving coil or crystal unit type, is generally employed. Their units move the air mass by means of a small trumpet horn. They are connected in parallel with the large speakers and add negligible load.

Of course, there are other types of loudspeakers which we must not overlook, particularly

(Page 12, please)

Page Eleven

Selecting and Connecting Suitable P.A. Systems

(Continued from page 11)

the simple magnetic cone reproducer. This unit has only a fair frequency response and will handle a limited power input. It is particularly used for small gatherings, and where it is not advisable to have a unit requiring a separate source of field excitation. For places where high fidelity is desired in a reproducer where no external excitation is available, a permanent magnet dynamic or moving cone unit is best.

Multiple headphone sets fall in the class of reproducers but are seldom used in public address work. However, they do find their use in churches and where gatherings are open to the public for people who cannot hear as well as the average.

Levels and Impedances. Every pickup unit will deliver a definite amount of output A.F. energy for normal input. This output, of

The real problem in public address systems is to combine the various pickups so that one may be used quickly in place of another and that their levels may be raised from some value far below 6 milliwatts to 5 or more watts. For this purpose the amplifiers play an important part.

For example, if the speakers are to be fed with 30 d b power and a -60 db. microphone output is used, then the amplifier must at least supply 60 plus 30 or 90 db. of amplification. Of course, a little more is necessary in order to take care of volume regulation.

Impedance Matching. It is not possible merely to connect a pickup to an amplifier and the loudspeaker to the amplifier and hope to get quality and efficient reproduction even though the necessary gain has been introduced. It is

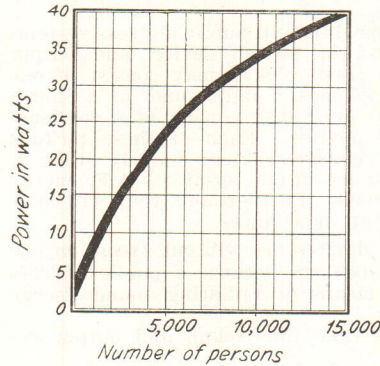
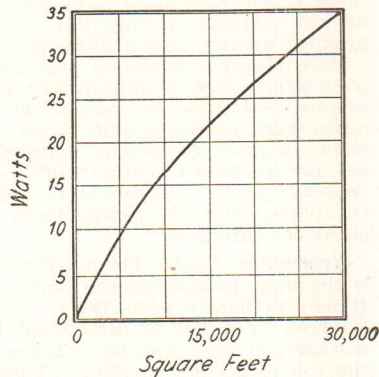

Fig. 1

course, is measured in watts or milliwatts. A more universal measure is the decibel which is a means of comparing ratios of power. When one power is not compared to another the level referred to is 6 milliwatts. 6 milliwatts is therefore called zero d b.

With the decibel as the gauge of output level you can understand the relative response of various pickup devices when we say that a double button carbon microphone will deliver -30 d b, a velocity or condenser microphone -60 d b, a phonograph pickup -10 d b, a radio tuner, of course, may deliver as much as 0 d b without the need of one stage of A.F. amplification.

Turning to the reproducers, try to bear in mind that the average moving coil loudspeaker will handle approximately 5 watts of power. Of course, in many cases it takes more than one speaker to cover a definite audience, therefore, two or more may be used together.

important that these various devices be connected so that the impedance of one, matches the impedance of the other at the point of connection. Pickups have various output impedances. That is, their output terminals not only have a definite level but a definite impedance. You shouldn't connect a 2,000 ohm phonograph pickup unit to a 200 ohm input amplifier. A matching device is necessary. There are two types of impedance matching devices generally used. One is the transformer which will match with high efficiency and is always used to connect two devices together where power must be conserved. On the other hand, if you wish to connect two devices together and introduce a definite loss, as for example, you would want to connect a radio tuner to a high gain amplifier, a resistive matching pad is generally employed.

(Page 28, please)

RADIO-TRICIAN SERVICE SHEET

REQ. U. S. PAT. OFF.

COMPILED SOLELY FOR STUDENTS & GRADUATES



GRUNOW RADIO Receiver Models 670-671 Chassis Type 6-D

ALIGNMENT

1. Equipment

A—Test Oscillator

A modulated Oscillator capable of producing signals at 455 K. C., 600 K. C., 1400 K. C., 4500 K. C., 12 M. C. and 21 M. C. is necessary for alignment of the Type 6D Chassis.

B—Coupling Means

Coupling Condensers of 200 Mmf., 25 Mfd., and a 400 Ohm resistor should be used when coupling oscillator, to receiver during alignment as specified in following paragraphs.

2. Dial Setting

Turn dial knob until condensers are fully meshed. The dial pointer should be on the horizontal line of the dial.

3. I. F. Alignment

Connect signal lead of test Oscillator to grid of the 6A7 (1st Detector Tube) through .25 Mfd. Condenser.

A—Set Dial Pointer to 1400 K. C. and range switch on position "A." (Broadcast).

B—Place test Oscillator in operation at 455 K. C. Turn receiver volume control and tone control to maximum.

—Attenuate test Oscillator output to lowest value consistent with obtaining a readable indication on output meter.

D—Adjust five I. F. Trimmers, (A1, A2, A3, A4, A5), located on the I. F. transformers on top of the Chassis, (2 Trimmers are on top of each transformer and the fifth is at the lower side of the 1st I. F. transformer.) (this is the Bi-Selector I. F. stage), until maximum output is obtained. During alignment maintain as low a value of signal as will allow obtaining of accurate adjustment.

4. 4500 K. C. Alignment

A—Connect signal lead of test Oscillator through 200 Mmf. Condenser to Antenna binding post.

B—Connect the test Oscillator ground lead to the ground post of Chassis.

C—Turn Range Switch to range "B" and set Dial Pointer to 4500 K. C.

D—Align the following "B" range trimmers: Oscillator (A6), Detector (A7), Antenna (A8).

5. 1400 K. C. Alignment

A—Place test Oscillator in operation at 1400 K. C.

B—Turn Dial to 1400 K. C.

C—Turn Range Switch to range "A."

D—Adjust the following "A" range trimmers: Oscillator (A9), Detector (A10), Antenna (A11).

6. 600 K. C. Alignment

A—Place test Oscillator in operation at 600 K. C.

B—Tune in signal to maximum (this point does not have to be exactly at 600 K. C. setting).

C—Adjust the 600 K. C. Padding Condenser, (A12), in direction of signal increase. At same time rock the tuning condenser back and forth through resonance while adjusting Padding Condenser until maximum output is obtained.

7. 12 M. C. Alignment

A—Connect signal lead of test Oscillator through 400 ohm resistor to Antenna binding post of Chassis.

D—Set Range Switch to range "C."

E—Adjust the following "C" range trimmers: Oscillator (A13), Detector (A14), Antenna (A15).

F—When adjusting the Detector Trimmer (A14) on the "C" range it is necessary to rock the tuning condenser in a manner similar to that required when setting the 600 K. C. Padding Condenser.

G—When adjusting the Oscillator Trimmer on the "C" range with a 12 M. C. signal it will be noted that there are two settings at which the signal will be received. Use the higher frequency settings, that is, the setting at which the trimmer screw is farthest out. On the "A," "B," and "C" range the Oscillator operates at a higher frequency than the incoming signal, and consequently the trimmer capacity will be lower when adjustment is completed.

8. 21 M. C. Alignment

A—Set Range Switch on range "D."

B—Place test Oscillator in operation at 21 M. C.

C—Turn Dial Pointer to 21 M. C.

D—Adjust the following "D" range trimmers: Oscillator (A16), Detector (A17), Antenna (A18).

E—When adjusting the Detector Trimmer (A17) on the "D" range it is necessary to rock the tuning condenser back and forth through resonance in the same manner as required when setting the 600 K. C. Padding Condenser.

F—When adjusting the Oscillator trimmer on the "D" range with a 21 M. C. signal it will be noted that there are two settings at which the signal will be received. Use the lower frequency setting, that is, the setting at which the trimmer screw is farthest in. On the "D" range the Oscillator operates at a lower frequency than the incoming signal, and consequently the trimmer capacity will be higher when adjustment is completed.

Readers who file Service Data on separate binders remove page carefully, trim on dotted line for same size as Data published heretofore.

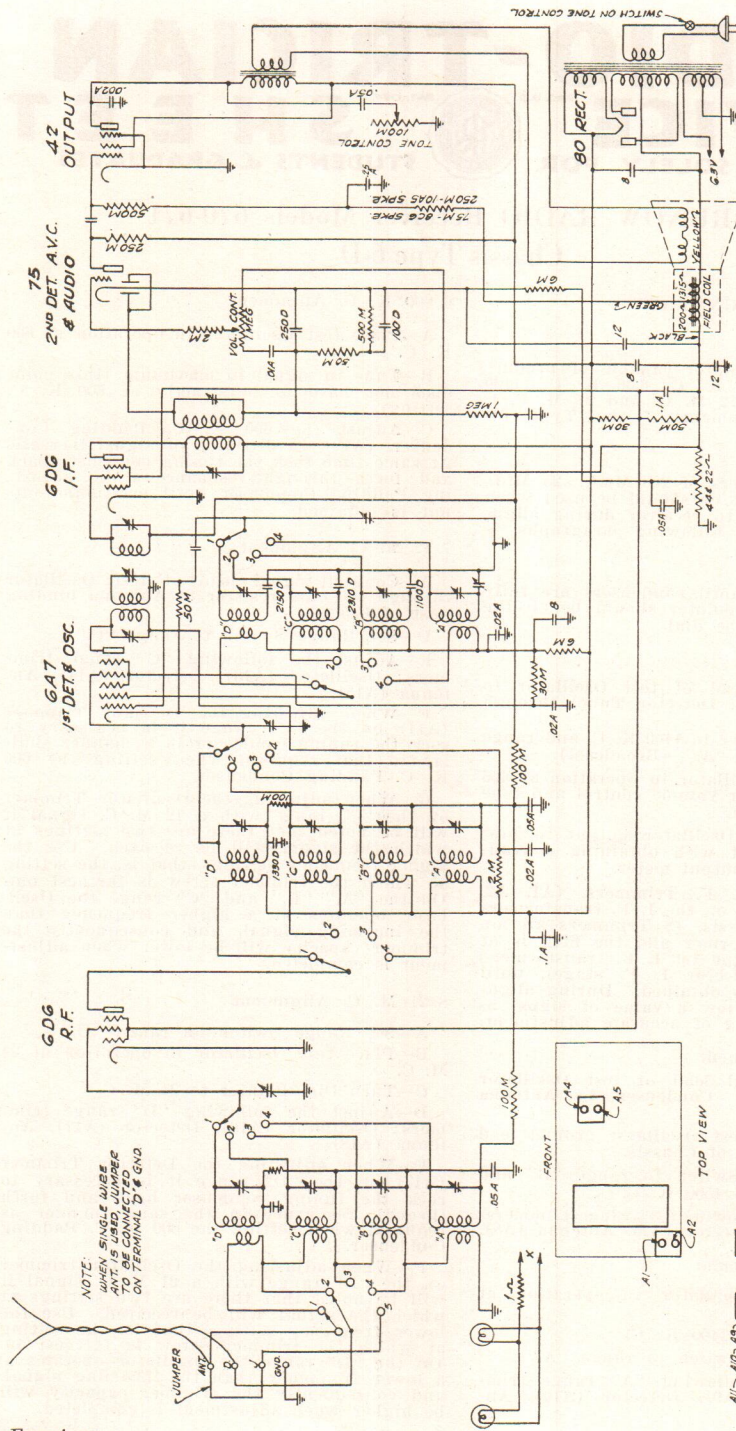

NOTE: WHEN SINGLE WIRE IS CONNECTED TO TERMINAL 'D' & END JUMPER

CONDENSER KEY	DESCRIPTION	CAPACITY
A	PAPER	MUF
D	MICA	MMF

- RANGE -
 A - 550 - 1500 K.C.
 B - 4.5 - 12.6 MC.
 C - 4.5 - 12.6 MC.
 D - 9.6 - 21.8 MC.

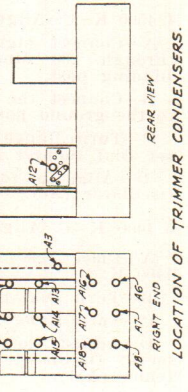

Grunow Radio
 CHASSIS TYPE G-D
 RECEIVER MODEL SPEAKER
 G-D 1095
 GENERAL HOUSEHOLD UTILITIES CO.
 RADIO SERVICE DEPARTMENT
 CHICAGO, ILL.

I.F. 455K.C.

What Our Readers Think of the New National Radio News

"I want to express my enthusiasm for your enlarged and very lively publication. What I like most about it is the fact that it combines a wealth of practical information and data with some progressive business ideas. I think that it will go a long way toward retaining an enthusiasm on the part of your students and alumni in the pursuit of profitable Radio service work."

GEORGE BRODSKY,
Allied Radio Corp.,
Chicago, Ill.

— n r i —

"NATIONAL RADIO NEWS is certainly an interesting publication and one which should do a lot of good."

DANIEL J. FAIRBANKS, *Sales Manager*,
International Resistance Co.,
Philadelphia, Pa.

— n r i —

"I have followed your publication for several years, and, as you know, have frequently contributed material on behalf of our various clients. I think this publication is doing an excellent job not only for your students and graduates, but also by way of bringing the Radio Industry in touch with worth while Radio men out in the field. I can frankly state that the interest shown and the inquiries received from various articles I have prepared for your publication, have even exceeded those displayed by regular Radio publications. You have here an ideal medium, and it is filling a real want. A mighty interesting magazine."

AUSTIN C. LESCABOURA.

— n r i —

"Our News is sure some paper now. The Service Forum is a priceless addition and the Mail Bag is also very helpful.

"Here's for our continued success with the News."

C. H. SWALLOW.

— n r i —

"I find NATIONAL RADIO NEWS interesting, especially as to the number of service hints included."

J. M. DEVOE,
Hygrade Sylvania Corp.

— n r i —

"How could any N. R. I. student or graduate help but like NATIONAL RADIO NEWS. All contributors are to be congratulated on this fine, helpful publication."

HARVEY C. MESSNER,
Tucson, Arizona.

"It was a pleasure to receive a copy of your 'NATIONAL RADIO NEWS' and it strikes me as just another indication of the far-sightedness which has always been a part of your activity.

"I feel very sure that this magazine will be helpful to you and your students and it will be a pleasure to receive it from time to time."

ARTHUR H. LYNCH, Pres.
Arthur H. Lynch, Inc.

— n r i —

"NATIONAL RADIO NEWS is a very complete publication, and one which should greatly enhance the value of your training to your students and graduates."

FLOYD FAUSETT, *Chief Engineer*,
Supreme Instrument Corp.,
Greenwood, Miss.

— n r i —

"Thanks for copy of 'NATIONAL RADIO NEWS.' Looks good."

F. A. KOLSTER,
Federal Telegraph Co.,
Palo Alto, Cal.

— n r i —

"I wish to acknowledge receipt of NATIONAL RADIO NEWS. This is one of the liveliest and best magazines of its kind I have ever seen, and I wish to compliment you on it.

"We are glad at any time to cooperate with you in every way possible."

J. K. ROSE, *Service Manager*,
Wells-Gardner & Co.,
Chicago, Ill.

— n r i —

"We believe the articles in NATIONAL RADIO NEWS will be of value to your student and graduate body. The Service Forum and Service Sheets are particularly interesting. We believe that publications of this type are essential where students and especially graduates wish to keep abreast of the rapidly growing Radio and television field."

J. M. BOWMASTER, *Service Dept.*,
Sparks-Withington Co.,
Jackson, Mich.

— n r i —

"I want to take this means of congratulating you on your excellent 'RADIO NEWS.' I have read it from cover to cover. The Service Forum is extra good with lots of meat in it. Keep up the good work for a bigger and better NATIONAL RADIO NEWS."

ALEXANDER BIRCH,
Honolulu, T. H.

Page Fifteen

MARINE

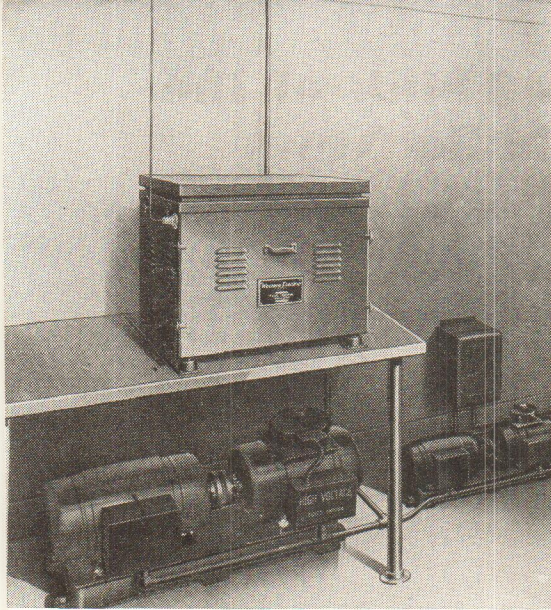

Cabinet assembly containing transmitter, receiver, and associated equipment, are shown installed in a convenient location below deck. Also power equipment. (Photo Western Electric)

YEARS ago when it was first discovered that Radio or wireless as it was then called, made it possible to converse between two distant points by the means of dots and dashes, it was considered that the most important use for this new medium of communication would be between ships at sea, and between shore stations and ships.

Therefore, Marine Radio is the oldest branch of the Radio Industry.

However, as years went by and new uses were found for Radio, the average person lost sight of the developments in Marine Radio, which became more and more the "forgotten man" of the industry.

Today, the public hardly realizes that there is such a thing as ship Radio unless this very important field crashes into the limelight as the result of a disaster at sea—after which it is soon forgotten. The general public is too interested in the broadcasting end of Radio—that end with which he is in daily contact—to take much interest in Marine Radio.

But as the result of painstaking effort on the part of several Radio organizations in this country, Marine Radio is making rapid advances—going forward with improvements with results which comparably equal those attained in the broadcasting branch of the Radio Industry.

Recent developments of the Bell Telephone Laboratories, the research laboratories of the American Telephone and Telegraph Company,

Page Sixteen

and the Western Electric Company are fine examples of the progress which has been made in Marine Radio equipment. For instance, today, Captains of fishing vessels, harbor crafts and yachts may have as efficient telephone service at sea as they have when they are ashore.

When within range of a Coastal Radio telephone station providing this service, Captains are able to talk to their offices, their homes, and in fact, to almost any destination as easily as they would on land.

They merely pick up a telephone, located for example, in the pilot house of the ship, press a button on the instrument and say, "Marine Operator." Promptly, a voice replies with a very familiar, "Number Please" and the call goes through as do millions of land calls daily.

The Radio telephone gives the ship Captain all the advantages that the ordinary land telephone gives the business man, and the Captain uses it in just the same way. Keeping his ship in close contact with his home office, the Captain is posted on market conditions so that he can act quickly to take advantage of favorable prices. It also is used to keep the Captain informed regarding weather conditions and so warn him of severe storms.

The value of the Marine telephone will be more apparent when it is realized that the mariner at sea has problems which the ordinary business man does not have. There are times, at sea, when minutes mean not only dollars and cents, but a matter of life and death. Faced by the possibility of those emergencies which may arise from foul weather or accidents to the crew, equipment, or vessel, the Captain can by means of the telephone present his problems direct to headquarters, discuss the matter and be advised with speed and thoroughness which can only be had by two-way conversation.

As much as the Radio telephone means to the Captain and his vessel, it is equally important to the home office. Headquarters keeps fully informed of the operation of

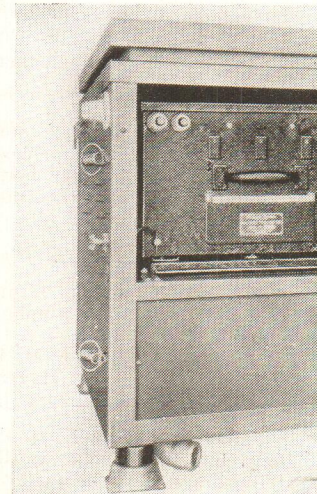

Cabinet assembly of Marine Radio transmitter, (upper left), the receiver, box and selector set.

RADIO

every unit in the fleet. It can direct and coordinate far flung activities swiftly and efficiently, because, by means of the Radio telephone, every unit is within easy hailing distance at all times.

Communication between ships is also possible. The call from one ship to another can be made either through a shore station or direct, by simple frequency shifts.

Lifting the telephone headset from its hook automatically places the apparatus in operation. The user presses a button on the handle of the telephone instrument when he talks and releases it when he listens. Other than this, telephoning aboard the vessel is just like telephoning on land. Regulations of the Federal Communications Commission permit the operation of Radio telephone equipment in the Marine service by persons holding a Radio telephone third-class operator's license. For this work, no knowledge of the Radio telegraph code is required.

The major units are the Radio transmitter, the Radio receiver, the control unit, the telephone set and the power equipment.

The transmitter is crystal controlled and is capable of delivering sufficient power to assure full 50 watts at any one of three pre-determined frequencies within the range of 1500 to 6500 kilocycles. It is capable of complete modulation of the carrier and the frequencies they deliver are well within the limit prescribed by the Federal Radio Commission. The antenna tuning equipment is sufficiently flexible to permit efficient adjustment to a variety of antennas.

The receiver is a light, compact unit of extreme selectivity. It is a six tube superheterodyne set with crystal controlled oscillator and is capable of operating on either of two pre-tuned frequencies within the band of 2100 to 2300 kilocycles. The shifting from one frequency to the other is made manually with a lever at the receiver, or, by a control unit in the pilot house. An automatic gain control maintains the audio output of the receiver practically constant for wide variations of

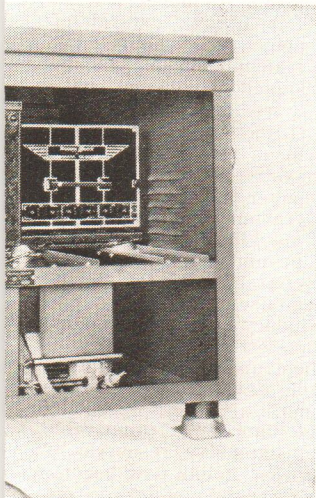

phone equipment, housing the transmitter (right), and below, the junction box. (Photo Western Electric)



Marine compass installation. Operator has left hand on wheel which rotates the loop installed on the roof of the pilot house. (Photo Western Electric)

signal strength. A newly designed ballast lamp insures correct filament current at the tubes under a wide voltage range in the power supply. The remote master control includes the start and stop switching facilities; the telephone headset mounting; the volume control; the output meter, and a bell and lamp which indicate when the receiver and transmitter are operating. Below the handset switch hook, which is a part of the control unit, is a silk-covered spring clamp in which the handset rests. This prevents it from swinging with the motion of the ship.

The control unit is built into a suitable housing with a one inch conduit opening at the bottom. Most of the apparatus is mounted on the inside of the front plate.

The selection of proper equipment necessary to obtain the voltages and currents required for the Radio equipment depends largely upon the type of power supply which is available on the ship. A large variety of power equipment is available to meet the particular needs of individual ships, including motor generators, dynamotors, turbo-generators and gas driven generators.

Another great Radio aid to marine navigation is the Radio compass.

The Radio compass is a development of the World War. Its usefulness during those years gave it a firm foundation for a subsequent rapid expansion as an invaluable adjunct to Marine

(Page 22, please)

Page Seventeen

ark without overlapping.

In adopting this system, the City of Newark is taking a leading part in opening up the new sector of Radio channels for police work throughout the United States. The medium frequency bands assigned for police work extend roughly from 1,600 to 1,700 kilocycles and from 2,300 to 2,500 kilocycles. These comparatively narrow bands are in many parts of the country completely occupied with police assignments. The ultra - high frequency band ranging from 30,000 to 42,000 kilocycles embraces a range of 12,000 kilocycles, within which a far greater number of police assignments may be made. The separation between ultra - high frequency channels, however, is very narrow and requires apparatus of great refinement, stability, selectivity and reliability, to be successfully used.

While a few communities have already tried ultra-high frequencies, Newark is a leader in putting in operation equipment of such design. The example it has set will no doubt result in making police Radio available to many other communities which at present have not been able to obtain assignments in the limited number of channels existing in the medium bands.

The Newark police Radio system purchased from the Graybar Electric Company, was designed by Bell Telephone Laboratories and manufactured by the Western Electric Company, most of the work being done at their plant at Kearny, N. J.

All police communication facilities have been concentrated in three adjacent rooms on the fourth floor of Police Headquarters, at the City Hall on Broad Street, Newark. In one room is the police telephone switchboard and in another the police teletype machines. The third room located between these two is the Radio room from which the police dispatcher broadcasts alarms to the motor patrol.

Page Eighteen

The Radio room contains a microphone and amplifiers as well as maps of the city giving the position of every police car. A fire alarm indicator is also in this room. The dispatcher controls the entire Radio system from this room by push-button control.

From here telephone and control lines lead to the 34th floor of the National Newark & Essex Bank Building, highest building in Newark, at which point is located the ultra-high frequency Radio transmitter and duplicate dispatching equipment which makes it possible to continue operation even though cut off from headquarters by some unexpected emergency. The entire transmitting apparatus is contained in a single cabinet, 7 feet high and 1 foot 9 inches wide. The transmitter draws its power directly from the power circuits of the building. Mercury-vapor rectifier tubes transform the alternating current into direct current of the proper voltages. Three tubes amplify the voice currents and there are four stages of amplification for the carrier or Radio frequency.

A quartz crystal of new type holds the transmitter on its assigned frequency with extreme accuracy. This tiny crystal, perhaps the most vital part in the system, is ground to paper thinness by skilled craftsmen using delicate machines. When so ground it has the characteristic of vibrating under electrical impulses at exactly one sixth of the carrier frequency or about 5,000,000 times per second, and thus establishes the fundamental frequency of the transmitter. Hitherto the best crystals available have required the use of heating devices to maintain their operating temperature within the narrowest practicable limits. As a result of extensive research by Bell Telephone Laboratories, it has now become possible to manufacture crystals which do not require the complications of these accessories to

(Page 21, please)

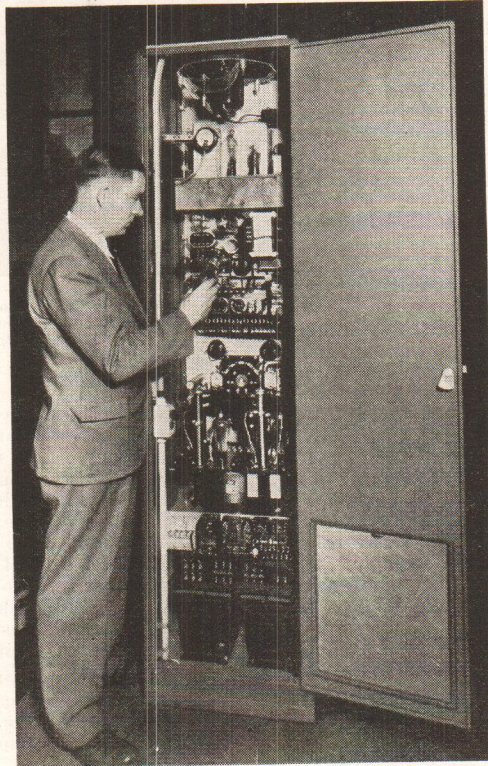

Inserting a tube in rear of the transmitter of Police Department at Newark. Photo, courtesy Western Electric Co.

RADIO-TRICIAN SERVICE SHEET

REG. U.S. PAT. OFF. COMPILER SOLELY FOR STUDENTS & GRADUATES



WESTINGHOUSE DUAL-WAVE RECEIVERS MODELS WR-28-29

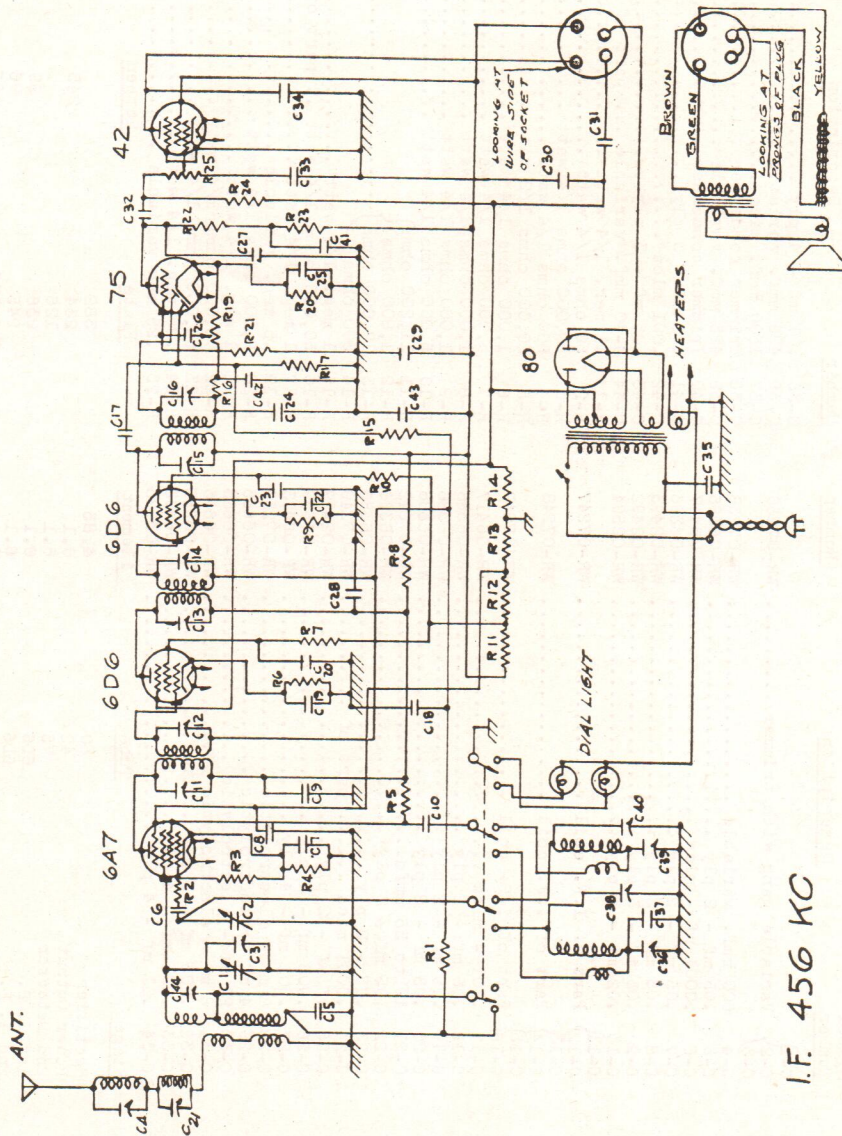

I.F. 456 KC

Page Nineteen

Readers who file Service Data on separate binders remove page carefully; trim on dotted line for same size as Data published heretofore.

WESTINGHOUSE DUAL-WAVE RECEIVERS MODELS WR-28-29

Symbol Number	Description	Part Number	Symbol Number	Description	Part Number
C-1	Variable gang with trimmer	WR-07256	C-35	.01 mf - 4 ply	WR-05951
C-2			C-36	425 mmf. variable	WR-07241
C-3			C-37	1500 mmf. mica	WR-07422
C-4			C-38	Trimmer condenser	WR-07237
C-5			C-39	425 mmf. variable	WR-07241
C-6			C-40	Trimmer condenser	WR-07237
C-7			C-41	.05 mf - 3 ply	WR-02492
C-8			C-42	.001 mica	WR-06417
C-9			C-43	.05 mf - 3 ply	WR-02492
C-10			C-44	4-40 mmf. variable	WR-07246
C-11	Part of I.F. coil	WR-07247	R-1	1 meg. 1/4 watt	WR-05278
C-12	Part of I.F. coil	WR-07248	R-2	50 ohms 1/4 watt	WR-05255
C-13	Part of I.F. coil	WR-07249	R-3	50,000 ohms 1/4 watt	WR-05275
C-14			R-4	500 ohms 1/4 watt	WR-05264
C-15			R-5	20,000 ohms 1/2 watt	WR-00813
C-16			R-6	1,000 ohms 1/4 watt	WR-05267
C-17			R-7	5,000 ohms 1/4 watt	WR-05249
C-18			R-8	1,000 ohms 1/4 watt	WR-05267
C-19			R-9	1,000 ohms 1/4 watt	WR-05267
C-20			R-10	5,000 ohms 1/4 watt	WR-05249
C-21			R-11	11,200 ohms	
C-22			R-12	1,800 ohms	WR-07236
C-23	R-13	12,000 ohms			
C-24	R-14	300 ohms			
C-25	R-15	1 meg. 1/4 watt	WR-05281		
C-26	R-16	50,000 ohms 1/4 watt	WR-07249		
C-27	R-17	1 meg. 1/4 watt	WR-05281		
C-28	R-18	5 meg. variable	WR-05562		
C-29	R-19	2,000 ohms 1/4 watt	WR-05245		
C-30	R-20	1 meg. 1/4 watt	WR-05281		
C-31	R-21	75,000 ohms 1/4 watt	WR-05277		
C-32	R-22	50,000 ohms 1/4 watt	WR-05276		
C-33	R-23	.25 meg. 1/4 watt	WR-05279		
C-34	R-24	.25 meg. 1/4 watt	WR-07250		
C-34	R-25	.25 meg. variable	WR-07250		
Stage	Tube	Filament	Plate	Screen	Cathode
Rectifier	80	4.85	382		18
Power Output	42	6.1	234	245	0.87
2nd Detector	75	6.1	126	99	5.6
1st I. F.	6D6	6.1	236	96	5.6
2nd I. F.	6D6	6.1	245	87	4.7
Oscillator	6A7	6.1	236-136		

Note: These values are readings of a high resistance voltmeter from each socket terminal to ground, with the exception of the filament voltages.

achieve the desired constancy of oscillation frequency.

A series of vacuum tubes multiplies the electrical oscillations of the crystal until they reach 30,100 kilocycles.

By several switches associated with four meters, the operator can instantly measure the performance of 14 circuits within the equipment. All tuned circuits can be locked to avoid tampering and to assure the permanence of adjustments once they are made. A blower in the top circulates cooling air through the transmitter, a spun glass filter at the bottom cleaning the air as it enters. The blower is rubber-mounted to prevent vibration. No live parts are exposed and a safety lock cuts out high voltages as soon as the back door of the transmitter is opened.

From the transmitter a "concentric" transmission line runs 100 feet to the roof of the building. This line consists of two copper tubes, one within the other, the outer being a little less than an inch in diameter and the inner somewhat smaller than a pencil. This one is held precisely in the middle of the outer by spaced rings of insulating material known as Isolantite. The outer tube is bare of insulation, coming directly in contact with bricks, plaster, etc., and acting as a ground.

The unique design of this transmission line makes it "water tight" as far as electric current is concerned. The entire electrical field is concentrated within a small space, none escaping beyond the outer tube. There is no loss of energy by radiation.

This line enters the bottom of a hollow steel flag pole which rises 100 feet from the roof of the building. The line runs up the inside of the pole to its tip. Projecting from the tip is a brass tube 22 feet high. The inner tube of the transmission line also projects from the tip of the flag pole, paralleling the brass tube about 7 feet. This sets up an electrical effect which prevents current from surging back into the transmission line and maintains a uniform current in the line. The remaining 15 feet of the brass tube, about 600 feet above street level, becomes the actual antenna or radiator, being half the length of the Radio wave.

About 25 police cars are equipped with receiving sets, the total planned being 40. The plan also calls for receiving sets in headquarters, precinct stations and the homes of a number of police and other city officials. A number of Fire Department official cars will likewise be equipped.

The receiving sets are of the 6-tube super-heterodyne type. They are 6 by 7 by 10 inches in size, including the loud speaker. Their operation is simple, involving only two controls, both located on the receiving set. One is the on-off switch which also controls volume. The

tuning of the receivers is fixed when they are first installed and the second control is merely to adjust them for small "drifts" in frequency, which may be necessary once or twice a day. This drift control is required on account of the extremely sharp tuning characteristic with which the receivers are designed to eliminate the possibility of interference. This second control can at any time be done away with by equipping the receivers at low cost with the same type of quartz crystal frequency control utilized in the transmitter, thus making the drift control automatic and still retaining the sharp tuning characteristic.

The loud speakers also have automatic volume control, preventing any sudden bursts of sound and similarly maintaining the volume in spots where reception weakens, such as behind some buildings which cast a "Radio shadow."

In the Ford coupes used by the Newark police, the car receivers are located to the rear of the seat. Rubber mountings protect them from jolts and vibration. The antennas are completely concealed so that Radio cars, if otherwise unmarked, cannot be identified. The sets are operated by dynamotors which draw their power from the batteries of the cars.

The Radio system was installed by the department of Public Safety under the direction of the Honorable Michael P. Duffy, Director. The personnel is under the charge of Deputy Chief John F. Harris, Newark Police Department. The Technical Engineer in charge of Radio System is John W. Kane. The Consulting Radio Engineer for the Department of Public Safety, City of Newark, is Paul F. Godley.

The Newark Police Radio Broadcast Room staff consists of one lieutenant and one sergeant in charge and eight policeman who broadcast the alarms. The staff of the transmitter station consists of one chief Radio operator and four Radio operators all of whom are policemen holding Radio licenses.

— n r i —

RCA MODELS LOW VOLUME AND 80 & 82 DISTORTION

This condition has often been traced to a defect in the cathode bypass condenser across the two 45's 715 bias resistor. The soldered connections at both the condenser and resistor should be checked.

— n r i —

RCA MODEL 86 POOR RECORDING

Try reversing the black and black-with-red tracer leads on the two terminals in back of the amplifier. If they are incorrectly connected the output circuit is shorted.

Marine Radio

(Continued from page 17)

traffic. Under the careful and painstaking guidance of the Navy Department of the United States, the number of shore stations equipped to supply Radio compass information to compass equipped ships has increased to 55.

The Radio compass indicates the bearing of the distant Radio stations—whether it be a station on land, a light ship, or another vessel—in terms of the “heading” of the vessel. It can be used in several different ways. The most common application is to determine the ship’s position by obtaining cross bearings from two or more Radio stations whose locations are known. In addition, the Radio compass may be used as a “homing” device. By its use, vessels can be steered directly toward a distant Radio station; for example, one located at a harbor entrance or on a lightship. In addition to these uses—there are many others. But the ones mentioned represent the Radio compass at its greatest value. It is almost unbelievable how accurate Radio compass bearing can be—and how accurately a ship may steer toward the transmitting station when the Radio compass is being used for a “homing” device. There is at least one instance, in the knowledge of your Editor, where a ship, “homing” under Radio compass signals, steered so accurately as to ram the lightship sending the signals in a dense fog.

The newer type Radio compass is much more simple of operation than those used in the years past. Such a Radio compass has been developed by the Western Electric Company and is pictured in operation, in this article. The receiving set of the Radio compass is very simple—operating in much the same form as an ordinary broadcast receiver. To use the compass it is only necessary to tune in the operating beacon signal by operating the tuning control on the receiver. Next the loop hand-wheel is turned in the direction which causes the indicator needle on the scale to follow in the same direction as the hand-wheel until the needle reaches the center line, at which time, the loop scale associated with the hand-wheel gives a bearing on the Radio beacon station.

NATIONAL RADIO NEWS wishes to thank the Western Electric Company for much of the information used in this article as well as for the accompanying photographs.

— n r i —

Recently I was checking an R.C.A. 80 for intermittent fading. The set played—but after being turned on a few minutes, the volume would drop slightly. All voltages checked O.K., but the set had a sort of crackling noise. Condensers and resistors checked O.K. In checking voltage at the plate of socket preceding 2nd intermediate, the crackling noise would be intensified. After taking shield off of 2nd interme-

Page Twenty-two

diate and checking primary, it was found to be open (checking with an ohmmeter).

This trouble can happen to intermediate frequency transformers, as well as primaries and secondaries of audio and by-pass condensers.

JOHN F. VYROSTEK,
Brecksville, Ohio.

— n r i —

Service Forum

(Continued from page 9)

volume control is used to stabilize the detector action of the 6B7 tube. Increasing its value will increase volume but if increased too far the set will be unstable. The best value may be found by experiment.

— n r i —

RCA VICTOR MODELS R-32, RE-45, R-52

FADING

This has quite commonly been traced to worn bearings in one or more of the variable condensers. The defective ones can be located by removing the top of the chassis, placing the tubes back in their sockets and operating the set while the condensers are being moved up and down with the fingers. In many cases these bearings can be tightened with an auxiliary spring tension device.

— n r i —

“We want to compliment you on your splendid magazine.”

L. B. HAMERSLEY,
Ohmite Manufacturing Co.

— n r i —

“I surely enjoyed the last number of ‘RADIO NEWS,’ and hope that it continues to grow and develop.”

DON R. BARKER,
Boulder City, Nev.

— n r i —

“I must congratulate you on the new NATIONAL RADIO NEWS. It’s really great so let’s have more of it. The service tips are a real service. Keep up the good work.”

WARREN MUNDIS,
Detroit, Mich.

— n r i —

“I think there has been a great improvement made in the ‘RADIO NEWS.’ The Service Forum sure does come in handy.

“The article on Ohmmeters by Mr. George Rohrich sure did give me a clear understanding about Ohmmeters and how to connect them.”

PAUL H. STEHLE,
Marcus Hook, Pa.

thanks . . . SERGEANT ALLDAY

Sergeant E. L. Allday, of Brookfield, Texas, has sent us some very interesting pictures, showing the surroundings in which he works.

He graduated from National Radio Institute in 1929 and his Radio work has brought him in contact with some very interesting experiences.

For a number of years he has held the position of Chief Radio Technician and in that capacity has had additional duties such as drafting, aeronautical observation, and Radio instructor.

As an observer and technician, he has been afforded the opportunity of visiting a number of the large Radio laboratories of commercial organizations and airways stations, and in that manner has been able to meet and make friends with any number of important and prominent people in the Radio field.

Among his associates, his knowledge of Radio is considered and accepted as the final answer to many problems in engineering and practice.

Sergeant Allday reports that his salary has been increasing right along, and he has every assurance that it will continue to increase.

In a recent letter to National Radio Institute, he informed us that he had purchased a \$3,000 automobile and now has a very nicely equipped laboratory for experimental work. We know of at least one offer he received of a position as communication advisor for a foreign government, the position carrying a salary of around \$6,000 a year, under contract.

To the right, we have reproduced the pictures sent us by Sergeant Allday. An explanation of the pictures follows:

1. A Ford Tri-Motored Airplane fully equipped for two-way Radio communication and used by the U. S. Air Corps.

2. Sergeant C. L. Allday (Air Corps) showing the inside of one of the late type plane high-frequency transmitters, by Westinghouse.

3. The latest thing on wheels for ground combat. Goes 100 miles per hour with constant two-way Radio communication. Uses a 75 watt telephone and code set with vertical, flexible antenna. Also used for communication with aircraft.

4. A formation of U. S. Air Corps planes under full command by means of Radio communication. Each plane is equipped for two-way work on telephone and code.

5. Eleven tons of steel. Goes almost any place with high speed. Has two-way Radio communication. Works with aircraft or other ground combat units.

The following is a quotation from a letter written by Sergeant Allday to N. R. I.: "I wish to say right here, that had I not followed your Course of instruction in the wonderful and clear manner in which your texts are written, I am most sure I would not be in the position which I hold today."

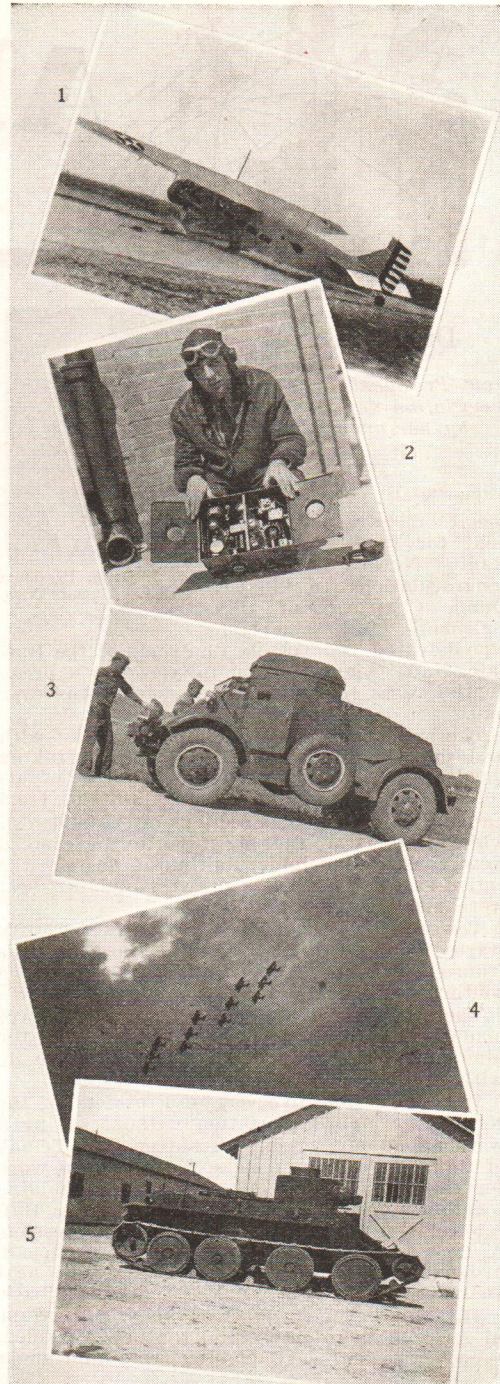

N.R.I. ALUMNI News

Dunn Elected

New President of Alumni Association defeats Telaak by narrow margin.

The N. R. I. Alumni Association has a new president for 1935. NATIONAL RADIO NEWS offers its congratulations to "Pete" Dunn, Chairman of the Baltimore, Md. Chapter, who defeated Ted Telaak, Chairman of the Buffalo, N. Y. Chapter, in one of the closest presidential races the Alumni Association has ever had.

The balloting started out nip and tuck—with first one candidate and then the other taking the lead. Telaak received the majority of his votes from the section around Buffalo, from Canada, and from some sections of the midwest, while Dunn was the big favorite in eastern New York, Philadelphia, Baltimore—in fact, the entire east coast. The southwest and far west were about equally divided.

Toward the end, however, Dunn's majority started to build up as a result of large returns from eastern New York, Philadelphia, and the southeast.

There is little doubt that the rapid advances made by the Baltimore Local Chapter in the nine months of its existence had a lot to do with the selection of Dunn for President.

It is impossible to speak of President of the N. R. I. Alumni Association without saying a word about our retiring President, Ted Telaak of Buffalo. Ted has done some wonderful work for the Association—and succeeded in holding together and building up a fine Chapter in Buffalo—during the worst years of the depression. A fine Radio man, a good organizer, an all-around good fellow. Who knows, what next year may bring forth? Maybe Ted will be back.

It is up to every member of the N. R. I. Alumni Association to get behind the new President—cooperate in every possible way and make

(Page 26, please)

Page Twenty-four



P. J. Dunn, President
N.R.I. Alumni Assn.

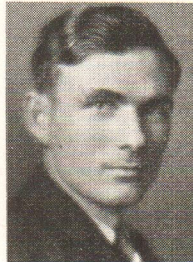

Earl Bennett,
New Vice-President

Chicago Chapter Chairman Gets Vice-Presidency

Earl Bennett bests Deschantz in balloting

There are a lot of happy Alumni Association members in the Chicago area these days. They have carried their popular Chairman, Earl Bennett, to a Vice-Presidency in the National Association.

Bennett has been doing some fine work with the Chicago Chapter despite some very adverse circumstances, and his perseverance has finally been rewarded by a National Association office.

Earl will, of course, continue as Chairman of the Chicago Chapter, and we know that his fellow members in Chicago will work with increasing vigor to put the Chicago Local across in 1935.

With the exception of P. J. Dunn, the newly elected President of the Association, Bennett is the only new officer to be elected this year. Lawrence Vanek, of Cincinnati, Ohio, retained his Vice-Presidency despite the efforts of our Canadian members to elect Arthur Ruse, Toronto Chapter Secretary, to that office. Fred Nichols, Denver, Colo., defeated C. H. Mills, of Detroit. Frank Parkins, Oglethorpe, Ga., beat out E. O. E. Gralley of the Baltimore Chapter.

G. C. Ruehl, Jr., Secretary-Treasurer of the Baltimore Chapter, gave our old friend Earl Merryman a good race for awhile, for the Secretaryship, but dropped behind in the late balloting. Merryman is the oldest officer in the National Radio Institute Alumni Association, having been elected at the Washington Convention of 1929 and served ever since. P. J. Murray, Washington, D. C., Executive Secretary, was re-elected to defeat A. H. Royce, of Winton, Wyo.

NATIONAL RADIO NEWS wants to take this opportunity to congratulate T. A. Deschantz,

(Page 27, please)

New York-Brooklyn Chapter

"Tops Them All"

Our November 16th meeting was held at the Crystal Recording Studios where the subject of discussion was "Recordings and Recording Equipment."

At that meeting we put over something entirely new in N. R. I. Alumni Association history. We recorded our meeting on a record and forwarded it to National Headquarters in Washington.

Earl Merryman, National Secretary, and Phil Murray, National Executive Secretary, had a chance to listen in to what went on at the New York-Brooklyn meeting.

Due to the press of other business matters, our genial Secretary, Forest B. Arnold, was forced to resign his office. He will continue as a member of the Chapter, however, and in his Secretarial duties we now have Lester Kershaw, of 4003 Soundview Ave., Little Neck, L. I., N. Y. And Lester is doing a good job.

At our December 20th meeting we had with us Phil Murray, from Washington, who came up to discuss plans for 1935, with the Executive Committee.

Here are a few service notes which I believe will be helpful to other members.

Majestic No. 70 and No. 90 Series.

Dynamic speakers have a tendency to buzz and rattle; look for an open seam in the cone. Reglue it with a preparation called Rapad. (Bookbinders use it in repairing books as a supplement for a cloth backing or for making scratch pads.) This preparation is also good for pasting your guarantee stickers on to the chassis (believe me they don't come off), or repairing voice coils that have become loose or any loose windings.

Shorts in Tuning Condensers.

Disconnect all wires. Use a 100 watt lamp in series with a pair of test prods (break one side of an extension cord and insert test prods); fasten one prod to chassis; touch the other one to the first tuning condenser rotor and turn from full mesh to full open. When the shorted part appears you will notice a spark and the lamp will light up. Check each rotor the same way. Most of the time you can burn the short loose with the arc.

Atwater-Kent No. 55.

A new place to look for Fading. A high resistance joint on the Antenna Coil.

(Page 30, please)

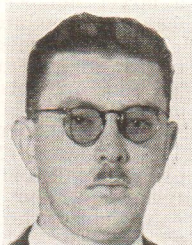

J. L. Kearns, New
York-Brooklyn
Chairman

Baltimore

"Watch Us Grow"

At the December 18th meeting of the Baltimore Local Chapter, officers were elected for the year 1935, as follows:

Chairman—P. J. Dunn.

Vice-Chairman—W. W. Jensen.

Secretary-Treasurer—G. C. Ruehl, Jr.

Assistant Secy.-Treas.—E. O. E. Gralley.

Librarian—F. Coonan.

Assistant Librarians—G. Rice, W. Giese.

Financial Committeemen—E. Duffield, I. Willet.

Sergeant-at-Arms—J. Ganz.

Assistant Sergeants-at-Arms—E. Traynor, E. Duffield.

As we write the copy for this issue of NATIONAL RADIO NEWS we are planning another big meeting—to be held in January—at which a special talk will be given on R. C. A. products and their service problems. This meeting has been brought about through the cooperation of the N. R. I. Alumni Association, Baltimore Chapter, the Southern Wholesalers, Inc. (R.C.A.-Victor Distributors), and the R.C.A. dealers of Baltimore. It will inaugurate the 1935 season of bigger, better Baltimore Local functions.

N. R. I. students and graduates in the Baltimore area, which comprises all of the counties surrounding Baltimore, are cordially invited to these meetings. If you are not familiar with the dates and the meeting place—a post card to P. J. Dunn, Chairman, 713 North Fulton Avenue, Baltimore, Maryland, or G. C. Ruehl, Jr., Secretary-Treasurer, Charleston and Second Avenues, Lansdowne, Maryland, will bring you the information.

— n r i —

Too Many Irons

(Continued from page 4)

main line and just one or two sets of various competing lines. These latter sets are only demonstrated on demand—or when a customer cannot be sold on the main line. This plan, while frequently used, is certainly not exactly fair to the manufacturer of the secondary line—and it is doubtful if the ultimate returns to those dealers justify the set-up. Don't let profit on an individual line of Radio receivers mislead you into taking on additional lines with the idea of additional profit, until you have thoroughly investigated and assured yourself that all other things being equal, your balance sheet will show a bigger profit at the end of the year.

Page Twenty-Five

Chapters To Get "Inside Stuff"

"Inside Stuff" was the subject of a talk given by P. J. Murray, Executive Secretary of the N. R. I. Alumni Association, before a meeting of the New York Metropolitan Area Chapter of the Association a short time ago.

It was well received, and the members of the New York Metropolitan Area Chapter requested copies of this talk be made and sent them.

Just before the close of the meeting, one of the members of that Chapter suggested that it might be a good idea to have copies of this talk sent to all Local Chapters, which suggestion will be followed out in the very near future.

— n r i —

New Chapter Publications

Following the example of the Baltimore Chapter which has now successfully operated a publication for its members for over six months, the Chicago Chapter is experimenting with such a publication.

We have also learned that the Philadelphia-Camden Chapter and the New York Metropolitan Area Chapter have voted to issue such a publication for their members in the very near future. Baltimore's paper is known as the "Baltimore Bulletin," while Chicago's is called "The Chicago Local." The name "Metropolitan News" has been suggested for the New York publication—but this has not been definitely decided upon. Philadelphia-Camden has not yet selected a name for its publication.

— n r i —

Last Minute Flashes

New York-Brooklyn Local Chapter changes its name to "New York Metropolitan Area Chapter."

James Kearns, Chairman, New York Metropolitan Area Chapter, rebuilds radio service shop to accommodate members of the Chapter desiring additional practical servicing experience. More about this later.

New York Metropolitan Area Chapter plans to organize employment department for its members. Numerous contacts which have been made by officers of that Chapter should be valuable to members seeking Radio connections.

— n r i —

Philadelphia-Camden

We are getting some real action at this Chapter now. The meetings are being attended by

Page Twenty-Six

a larger number of members, because we are making them interesting and instructive.

For some time the members have been working on an All-Star Receiver that we have been building, and this is furnishing practical experience for some of the younger men, as well as interesting experimental work for all of us. The reviews of N. R. I. Textbooks, conducted by Mr. Schiavoni, are also very popular. It is remarkable how little problems do clear themselves up, when discussed by a group of fellows who all speak the same language and who are all interested in the same things.

At our November 20th meeting, which, by the way, was one of the largest that we have had so far, we had with us Mr. Jos. Kaufman, Educational Supervisor of the National Radio Institute, who talked on the Art and Science of Radio Servicing. Mr. P. J. Murray, Executive Secretary of the Association, was also present and spoke on Radio as a Business.

Another very interesting discussion was held on the G.E. S22 receiver.

Some changes have occurred in two of our Committees. The resignation of Mr. Alfred Koch of the Ways and Means Committee was accepted and Mr. Allen Schiavoni appointed to fill the place. Mr. Jos. Strano was appointed as an additional member of this committee. Mr. Harry Esenwein still remains on this Committee, which has been termed by the members of the Local as the "Three Musketeers." Mr. Ronald Clarkson tendered his resignation as Chairman of the Publicity Committee. Mr. Jos. Pretzn replaces him on that job, and Mr. Milton Taggart has been appointed an additional member.

In the very near future we will begin publication of a special paper for the benefit of our Philadelphia-Camden members. This paper will be patterned somewhat after the "Baltimore Bulletin" which has been so successfully published by the Baltimore Chapter for about six months.

— n r i —

Dunn Elected

(Continued from page 24)

1935 the biggest year and the best year the Association has had so far. The various Local Chapters can do their part by putting their shoulders to the wheel and having bigger, more instructive, more interesting meetings than ever before.

— n r i —

Sympathetic

Prof: "If there are any dumb-bells in the room, please stand up."

A long pause and then a lone freshman stood up.

"What, do you consider yourself a dumb-bell?"

"Well, not exactly that, sir, but I hate to see you standing all alone."

Cleveland Chapter

Another concentrated effort is being made by Charles Jesse and J. C. Hannum, Chairman and Secretary of the Cleveland Chapter, respectively, to build up this Local as a part of the 1935 Campaign of the N. R. I. Alumni Association.

As a part of this drive, it is planned to have a Rally Meeting, some time during the month of January, to which all the members of the Alumni Association in the Cleveland Area will be invited. At this meeting P. J. Murray, Executive Secretary of the National Association in Washington, will be present and address the meeting on the plans for 1935.

The Cleveland Chapter has suffered as a result of the depression, and repeated efforts have been made to get it on a firm footing, now that conditions are better. It is hoped that every loyal Alumni Member in the Cleveland Area will back up this movement, and put the Cleveland Local where it belongs.

Cleveland is a big city, a live, wide-awake city. It deserves a good Chapter, and that is what we aim to give it.

— n r i —

Detroit Chapter

Servicing seems to be the matter of chief interest to the members of the Detroit Local Chapter, and consequently the officers are giving the boys what they want, and what they feel will do them most good.

Members have been bringing receivers to the meetings for servicing for the benefit of all present. First, a diagram of the receiver is placed on our blackboard, then a discussion and the actual servicing takes place. There is lots to be learned—and lots that can be learned under such a procedure.

The members have decided to remain at the present quarters of the Chapter for at least the next six months. The club rooms will be improved in appearance and convenience. It was also decided to get R.C.A. Manuals for the Local Chapter's library.

Plans were also made to attend the R.C.A. Group Service Meetings at the Detroit-Leland Hotel, our members being guests of the Radio Distributing Co.

Another new member has been admitted, Mr. M. E. Nivala of this city. For the benefit of persons seeking information regarding the Chapter, write C. H. Mills, Chairman, 5458 Fifteenth St., Detroit, Mich.

— n r i —

Toronto Chapter

There is an ever-increasing interest becoming apparent in connection with the Toronto Local

Chapter of the N. R. I. Alumni Association. Such an interest, in fact, that our Secretary is having a time keeping up with the correspondence which is coming in to "Canada's First Chapter" of the Association.

He has found it necessary to have several forms processed to care for special information.

The following are the officers elected for the year 1935:

Willis Forward, Chairman.
A. G. Ruse, Secretary-Treasurer.
Ed. Solman, Librarian.
A. Stollard, Finance Committee.
N. Miller, Finance Committee.

It has been decided that election of officers in the Toronto Chapter will be held in the future at the meeting nearest to November 1st of each year.

An interesting meeting has been arranged at which Mr. S. A. Goldhamer, Engineer-in-Charge, Special Products Department, Northern Electric Co., will speak. His subject, "The Recording and Reproduction of Sound Pictures," is sure to meet with the approval of the members.

The officers of the Toronto Chapter have found what they consider to be an ideal meeting place. It is centrally located, has blackboards and other necessities, and best of all, they have obtained it *free of charge*. It is surprising how many Chapters could get their meeting places free, if they appointed a housing committee of really conscientious fellows who would go out and contact the proper persons. Schools, Lodges, Churches, Political Organizations have meeting places and in many instances they will let the Chapters have them free, when they learn the type of organization the Chapters represent.

Toronto particularly invites out-of-town students and graduates to attend meetings. At present we are the only Local Chapter of the Alumni Association in Canada. It is therefore up to us to serve as many Canadian N. R. I. men as possible. For particulars of any meetings, write or phone W. Forward, Chairman, 8 Bracondale Hill Road (Melrose 5510), Toronto, or A. G. Ruse, Secretary, 449 Roehampton Ave. (Mohawk 3461), Toronto.

— n r i —

Chicago City Vice-Pres.

(Continued from page 24)

Chairman of the Pittsburgh Chapter, who was defeated by Earl Bennett for the Vice-Presidency, for the fine work he has done while in a Vice-President's office. Deschantz, of course, will continue as Chairman of the Pittsburgh Chapter.

Page Twenty-seven

Chicago Chapter

We are still "doing business at the old stand" here in Chicago. This city was rather hard hit during the depression, and it took us longer than some other cities to pull out of it, but we are coming along now and expect to improve greatly.

Our plans are to cooperate closely with National Headquarters to build up this Chapter during 1935, and National Headquarters is in turn cooperating with us to a great degree.

As we write the copy for this issue of NATIONAL RADIO NEWS we already have irons in the fire for a big rally meeting, during January, to which every Alumni Association man in these parts will be invited, and at which our Executive Secretary from Washington will be the guest speaker.

We will endeavor to build up our new Local Publication "The Chicago Local" to a point where it is a real help, and with the bigger, better meetings we hope to have this year—*Chicago Can't Miss!*

— n r i —

Associate Editors To Get Additional Help

In the past, some of the Associate Editors of NATIONAL RADIO NEWS (Chairmen of Chapters or someone delegated by them for the duty), have failed to get their Local Chapter copy in NATIONAL RADIO NEWS because it arrived in Washington too late to be included. NATIONAL RADIO NEWS must go to press well in advance of the date that it is mailed out, and this sometimes causes the difficulty just mentioned.

To eliminate this, to give every Associate Editor a chance to get his news in to Washington in plenty of time, National Headquarters will notify each Associate Editor, several weeks before the "deadline" date, that his copy must be sent in.

This will act as a reminder, and relieve the burden of remembering it from the Associate Editors.

Let's all thank the New York Metropolitan Area Chapter for this suggestion.

— n r i —

Selecting and Connecting Systems

(Continued from page 12)

Now it is not necessary for you as an ordinary installation man to know how these devices are designed or built. All you need to do is merely ask your distributor for a matching transformer to connect, let us say, a 2,000 ohm device to a 500 ohm device. If you are asking for a pad, you should give the same connecting impedances and at the same time specify the db. attenuation. Bear in mind that attenuated pads are generally used to connect pickups to

Page Twenty-eight

the amplifiers only when a loss is desired. When you connect the amplifier to loudspeakers a matching transformer is universally used. The ordinary dynamic or moving coil unit has a terminal impedance of 10 to 20 ohms, where the output and input of most amplifiers have a terminal impedance of 200 or 500 ohms, and they must be matched. Don't be too exact about this. There is very little loss by connecting a 500 to a 400 impedance although in an original design, exact matches should be attempted.

Mixers. When several pickup devices are used to feed into a common amplifier it is necessary to have a means of switching from one pickup unit to another. A mixer is nothing more than a variable constant impedance potentiometer which allows you to reduce the level to zero from one device and raise it to the level of another device which you wish to put into the circuit. There should be as many constant impedance controls as there are pickup devices to be used or to be used in the future. Of course, these controls may be connected in series or in parallel to a common coupling device which may either be a resistance pad or more usually a transformer. You may also use with a mixer one or more pickup units simultaneously as is often done with several microphones.

Pre-Amplifiers. If you wanted to use a phonograph pickup, a radio tuner and a velocity microphone feeding into a common amplifier you will need in addition to the mixer some means of bringing the levels of the various pickups up to the same db. level. This is necessary so that switching from one to the other will not result in undue differences in output. It is generally considered the best practice, to raise the level of the weakest pickup to the level of the strongest pickup by means of an associated amplifier, called a pre-amplifier.

In other words, if you were using a microphone and a phonograph pickup, you would attempt to raise the level of the velocity microphone to the level of the phonograph pickup. On the other hand, if you were also using a radio tuner, you may wish to bring everything to the level of the phonograph pickup in which case a pre-amplifier would be used with the velocity microphone and an attenuation pad with the radio tuner.

Main Amplifier. Assuming now that by the use of mixers and pre-amplifiers that the output from the mixer for various pickup devices will be at the same level. The question now arises shall the main amplifier be one or several units. For a permanent installation it might well be one unit, sufficient to take the level of an ordinary phonograph pickup to the required output for the speakers.

Where there is some doubt as to the output or power required it is best to break the main amplifier into two sections; namely, one volt-

(Next page, please)

Selecting and Connecting Systems

(Continued from page 28)

age amplifier and one or more power amplifiers.

Each power amplifier may well be of the 10 or 20 watt type so that two or four speakers may be coupled to the output of each one through suitable matching transformers.

The voltage amplifier then raises the output of the mixer to the level necessary to drive these various power amplifiers in parallel.

Separate units should always be considered where an expansion of the system is eventually to be considered.

Summary. Looking broadly at a public address system, start with one or more pickup devices amplified with a pre-amplifier or attenuated with a pad so that their outputs will be equal.

A mixer is then used to switch one or more of these pickup devices into the main system simultaneously.

The mixer is followed by a voltage amplifier and then by one or more power amplifiers. The power amplifier then feeds into reproducers.

And what is always important, every connection must be properly impedance matched.

Power Output Required. It is a well known fact that more output power is required for outdoor sound amplification than for indoor for the same number of people. For general purposes, you may use Figures 1A and 1B as a guide. You will notice that the power output in watts is specified for a given number of persons for indoor systems and a given number of square feet in outdoor systems.

Use Fig. 1A for outdoor and Fig. 1B for indoor installations. These charts assume that normal efficient loudspeakers are used.

It is wise in every case to use loudspeaker units capable of handling 5 watts, for if greater power is desired these separate units may be directed over the audience and thereby gain better coverage.

————— *n r i* —————

Sinister looking individual (significantly)—
"Is yer 'usband at 'ome ma'am?"

Lady (resourcefully)—"Well, if he's finished his revolver practice, he'll be playing in the garden with our bloodhounds. Do you want to see him?"

————— *n r i* —————

Dear Old Lady—"Captain, would you please help me to find my stateroom?"

Captain—"Have you forgotten what number it is, Madam?"

Lady—"Yes, but I'll know it if I see it again; there was a lighthouse just outside the window."

More Service Notes

RCA MODELS 80 & 82 INTERMITTENT FADING

This is generally due to a short internally in one of the audio transformer windings. Let the receiver play until the volume drops. Then check the resistance at the windings with an ohmmeter. The primary of the input transformer is rated at 2,000 ohms, 13,000 ohms exist across the entire secondary. The primary of the output is rated at 350 ohms while its secondary is rated at .8 ohms. In the latter case a satisfactory measurement could not be obtained. Localize the trouble with a pair of phones across the primary, listening in on the signal. The 4.5 mmfd. used to couple the R. F. to the first detector has been known to intermittently go bad as has the .5 mfd. screen grid bypass.

————— *n r i* —————

STEINITE MODELS 70 & 80 OSCILLATION

Check the .5 mfd. R. F. bypass condenser. If it is open oscillation will occur. The best way to check it is to bridge across it with another of equal value.

————— *n r i* —————

STEWART WARNER MODEL R-100 OSCILLATION

Oscillation will occur at the high frequency end of the dial if the old type screen grid tube is replaced by the quick-heater type 24A. By connecting a .5 mfd. condenser from the screens to the chassis, the tendency to oscillate will be reduced. Reducing the screen voltage will also clear up the trouble but will result in lower sensitivity.

————— *n r i* —————

GENERAL ELECTRIC MODEL J-125 HUM AND NOISE

Make sure that the yellow lead is connected to a good ground. The volume control leads must be well twisted to reduce or prevent hum.

————— *n r i* —————

KOLSTER MODEL K-43 INTERMITTENT NOISE

This trouble may be made to occur by jarring set. It has been traced to shorting of the tuning circuits, causing everything ahead of the detector to go dead. The short occurs between the shielding on the control grid leads and control grid cap, through the insulating rubbers. These rubbers lose their elastic property and become soft—the shield working under them. Use of rubber tape will clear up the trouble. Also examine the tuning condensers as some of their plates may be shorting.

(Page 30, please)

Page Twenty-nine

New York-Brooklyn Chapter

(Continued from page 25)

Pilot Lights.

When a job comes into the shop for repairs be sure and replace the pilot light if it looks like it has been there for some time. It might save you a call back.

Stromberg-Carlson.

When complaint is "I am only able to get one station," look for loose screws that hold the dial to condenser shaft. On repairing these sets, always check for bad volume controls; when the complaint is noise, watch out for noisy Audio Transformers.

Colonial 31-32-33-34.

No volume. Look for set screws holding r-f coils to shaft. Use adjustable r-f primary for volume control.

Kolster 6J-6K, etc.

In replacing the volume control, connect filament leg from original volume control direct to prong of 26 tube; install a 10,000 Ohm Pot. Connect Ant. and Gnd. to outsides and Ant. Coil to arm.

Replacing Kylectron Speakers (Peerless)

In replacing Kylectron Electrostatic speakers with a Dynamic speaker, replace the 2650 ohm resistor with the speaker field which must be 2500 ohms. Use a celotex baffle approx. 28"x28" to fit the entire space formerly occupied by the other speaker. Build a shelf for the speaker to rest on.

— n r i —

More Service Notes

(Continued from page 29)

KOLSTER MODELS INTERMITTENT K-43 & K-44 RECEPTION

Check the soldered connections on the speaker leads and also the R. F. choke in the plate circuit of the detector. In the K-43 a quick check on the audio system and speaker is obtained by plugging a pair of phones into the phonograph jack, which places the phones across the 1st transformer's primary. The phones may then be used as a microphone.

— n r i —

Portly gentleman—"That fellow spoiled my marriage."

Friend—"How?"

Gentleman—"He married my cook, and now my wife does the cooking."

Page Thirty

National Radio News

"from the Pioneer Radio Home Study School"

Vol. 6
No. 6

Feb.-Mar.
1935

Published every other month in the interest of the students
and Alumni Association of the

NATIONAL RADIO INSTITUTE
Washington, D. C.

The Official Organ of the N. R. I. Alumni Association
P. J. Murray, Managing Editor

Index

Article	Page
The President's Page.....	2
Newark's Police Radio.....	3
Too Many Irons in the Fire.....	4
Service Forum	5
Auto Radio Battery and Antenna Chart..	6
Easy Measurement Chart.....	7
Several Service Hints.....	8
Selecting P. A. Systems.....	11
Data Sheet Grunow 670-671.....	13-14
What Our Readers Think.....	15
Marine Radio	16-17
Data Sheet Westinghouse NR 28-29....	19-20
Alumni News	24 to 30
Mailbag	31
Calcaterra Service	32

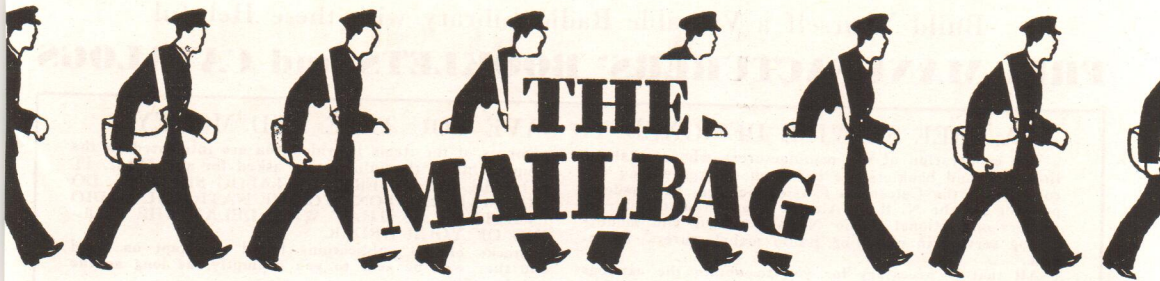

Our Ham List Grows

J. N. Proudfit, W8AHX, Burgettstown, Pa.
D. C. Allensworth, W9LQW, Junction City, Kan.
G. H. Brill, W1GC, West Haven, Conn.
T. B. Lucy, W5ELU, Little Rock, Ark.
J. C. Slack, W2DGJ, Jamaica, L. I., N. Y.
A. J. Boubreau, W8KTC, St. Clair Shores, Mich.
J. R. Schneider, W4DEP, Memphis, Tenn.

There are a great many N. R. I. men holding amateur licenses and for them exists a wonderful opportunity to break some records. Transmission on five and one and a quarter meters has just begun. No one can say what will happen. No one can say what results will be obtained. Two way communication between Hartford and Boston has been accomplished on five meters, but the surface has just been scratched. N. R. I. men equipped with their training should be able to accomplish something in this new field. Not long ago the limit of five meter communication was thought to be the visual area from the transmission point, but over a hundred miles has been covered. Let's go! Let it be a N. R. I. man to break the next record on these ultra high frequencies. N. R. I. has given us the fundamentals; now let's find out something for ourselves.

FRED PRITCHARD,
W1AQU, Wethersford, Conn.

— n r i —

To Mailbag Editor:

I am going to write to the best of my ability what I think of the Mailbag and NATIONAL RADIO NEWS. The helpful hints in Mailbag and the "News" have pulled me out of tough spots.

The "News" also keeps me posted on what's going on at the N. R. I. The articles which Mr. Smith and other members of the Institute write certainly give a fellow a lot of help.

I have plenty of work to do although it is spare time. I received my Diploma the other day and am very proud of it.

FRANK LUCCHESI.

I am herewith mailing the last lesson in my Advanced Course.

I wish to use this form of thanking you and your staff for the accurate, courteous, and prompt way in which they have handled my lessons. I thoroughly believe that I have obtained as much knowledge of Radio and Television from my course as if I had been under personal supervision in a classroom. I find your course just as good as you said it was and even better.

Since beginning your course I have been doing considerable Radio service work and I am well pleased with the course.

R. L. ROBERTSON,
Richmond, Va.

— n r i —

All servicing should be done in the shop providing the set owner can be convinced but occasionally the Radio-Trician finds one who wants all the work done in his sight. I find this class in the minority. I only make minor repairs, like replacing tubes, resistors, cable drives, oiling or aligning tuning condensers, and such adjustments in the home, but insist on taking the Radio to the shop for any other work. I like to have the Radio in the shop so I can keep it in operation for several hours to see if it functions properly. This would be impossible in the home on account of loss of time.

All my work is guaranteed for 90 days, so I like to satisfy the first time. A pleased customer is a real asset in the service business. When servicing in the home, one is apt to give the owner a "low" feeling when he starts to disassemble the Radio. If they watch you and possibly are talking it bothers you. Where there are small children in the home they often pick up parts and tools and misplace them.

My biggest argument for shop work is a person can do better work where he can be doing some deep thinking as he works or tests.

EDW. S. PERRINE,
Girard, Ill.

Page Thirty-one

Build Yourself a Valuable Radio Library with these Helpful **FREE MANUFACTURERS' BOOKLETS and CATALOGS**

A FREE SERVICE DESIGNED TO SAVE YOU TIME AND MONEY

The cooperation of the manufacturers whose catalogs, literature and booklets are listed on this page, and the courtesy of the Calcaterra Catalog Service, has made it possible for the N. R. I. Alumni Association to offer to readers of National Radio News a unique and money-saving service in obtaining Radio manufacturers' literature.

All that is necessary for you to obtain the catalogs or other literature listed on this page is to write the

numbers of the items in which you are interested on the coupon, fill in the information asked for and MAIL IT TO THE CALCATERRA CATALOG SERVICE. DO NOT MAIL COUPONS TO THE NATIONAL RADIO INSTITUTE AS THAT WILL DELAY THE FILLING OF YOUR ORDER.

Stocks of the publications listed are kept on hand and they will be sent to you promptly, as long as the supply lasts.

- 2. HAMMARLUND 1935 PARTS CATALOG. 10 pages. Variable and adjustable condensers, sockets, coils, intermediate frequency transformers, chokes, etc., for broadcast and short wave work.
- 4. HAMMARLUND-ROBERTS 15 TO 200 METER COMET "PRO" SUPERHETERODYNE. Details of a receiver designed especially for laboratory, newspaper, police, airport and steamship use.
- 5. ELECTRAD 1935 CATALOG. 16 pages. Standard and replacement volume controls, Truvolt adjustable resistors, voltage dividers, vitreous enamelled fixed resistors, public address systems, etc.
- 6. AMPERITE REAL LINE VOLTAGE CONTROL. Characteristics, uses and chart showing the correct Amperite recommended by set manufacturers for their sets.
- 25. LYNCH NOISE-REDUCING ANTENNA SYSTEMS. This folder describes in detail, and gives installing instructions for the various types of noise-reducing antenna systems developed by Arthur H. Lynch, Inc. Descriptions and prices cover the Lynch High Fidelity Antennas, the Lynch Marconi All-Wave System Antenna, the Lynch

NoStat Broadcast Kit, the "Giant-Killer" Kit and many other Lynch Antenna specialties.

26. LYNCH AUTO RADIO ANTENNAS, FILTERS AND NOISE SUPPRESSORS. This folder describes a complete line of Lynch antennas, filters and ignition noise suppressors, especially designed for motor Radio installations. Complete data on how to eliminate motor Radio noise is included.

27. THE LYNCH AUTOSTAT CHARGING RATE BOOSTER. This folder describes the new Lynch Autostat designed to automatically increase the charging rate of the automobile car generator by five amperes every time the car radio is turned on so as to eliminate danger of running down the car batteries when the radio is in operation.

34. ELECTRAD SERVICEMEN'S REPLACEMENT VOLUME CONTROL GUIDE. A 44-page vest-pocket size booklet containing a revised, complete list, in alphabetical order, of over 2,000 different receiver models with the proper type of Electrad Control to use for replacements.

56. SUPREME SERVICING AND TESTING INSTRUMENTS. A catalog containing complete descriptions of a new line of Supreme low-price analyzers, set testers, tube testers, ohmmeters, capacity testers, oscillators and universal meters.

57. HOW TO BUILD A HIGH-QUALITY CONDENSER OR RIBBON MICROPHONE. This circular describes the Superior Microphone Kit and instruction sheets with which it is possible to build, quickly and easily, a high-quality condenser or ribbon microphone. The kit is made by the Amperite Corporation.

60. AMERTRAN AUDIO AND POWER TRANSFORMERS AND CHOKE COILS FOR USE IN PUBLIC ADDRESS AMPLIFIERS AND RECEIVERS. A booklet containing very complete information on the characteristics of a wide variety of AmerTran De Luxe and Silcor (popular priced line) audio and power transformers and chokes.

65. NEW SUPREME 1935 LINE OF TESTING INSTRUMENTS. This booklet gives complete information on the new 1935 line of Supreme testing instruments including the new 5" Supreme fan shape meter, the new Model 333 DeLuxe Analyzer, the low-priced Model 333 Standard Analyzer and the Improved Model 85 Tube Tester.

66. A SUPREME A.C.-D.C. TESTER WHICH CAN BE BUILT AT HOME AT LOW COST. This folder gives complete information about the Supreme 5" fan shape meter, rectifier and resistor kit for the home construction of an inexpensive A.C.-D.C. tester.

71. TRY-MO 1935 RADIO PARTS AND SETS CATALOG. A 181-page catalog issued by Try-Mo Radio Co., Inc., listing and illustrating the wide variety of sets, chassis, standard, special and replacement parts, tubes, tools, public address systems, amplifiers and other electrical equipment required by servicemen, experimenters and set builders.

72. SKYRIDER SHORT WAVE RECEIVERS. Describes the various types of tuned radio frequency and superheterodyne short wave receivers built by Hallicrafters, Inc., featuring ranges of 13 to 200 meters (with broadcast or 10 meter band optional), automatic wave change switch, continuous band spread, built-in monitor, speaker and power supply (or batteries), high fidelity audio and other refinements.

(Please Use Pencil and Print in Filling in Coupon)
THE CALCATERRA SERVICE NRN-235
Thornwood, N. Y.

Please send me, without charge or obligation, the catalogs, booklets, etc., whose numbers I have filled in below.

Booklet Numbers:

-
.....
My connection in Radio is checked off below.
 Serviceman operating own business
 Serviceman employed by:
 Manufacturer
 Jobber
 Dealer
 Servicing organization
 Dealer
 Jobber
 Radio Engineer
 Experimenter
 Laboratory Technician
 Professional or Amateur Set Builder
 Licensed Amateur
 Station Operator
 Manufacturers' Executive
 Student
 Public Address Work

I buy approximately \$00 of Radio material a month.
(Please answer above without exaggeration or not at all.)

Name

Address

CityState