

# RADIO AGE

*The Magazine of the Hour*

JUNE  
1924

## In This Number

Important Factors in the  
Construction of a Super-  
Heterodyne.

A Universal Amplifier.

Complete Instructions for  
Building a Sure - Fire  
Reflex Set.

Radio Age Data Sheets.

Corrected List of U. S.,  
Canadian and Cuban  
Broadcasting Stations.

How the Fight to Tax  
Radio Failed.

Pickups and Hookups by  
Our Readers.

Up-to-the-Minute News  
Pictures.

Authentic Radio  
Diagrams.

Other Timely  
Features.



Price  
**25**  
Cents

*Let Our Hook-ups Be Your Guide*

# Your Radio Problems Solved for 30 Cents in Stamps

**I**F YOU are constructing a receiving set, and you need help in the way of clear diagrams and full detailed descriptions you may have it by return mail.

We have laid aside a limited number of back numbers of Radio Age for you. Below we are listing the hook-ups and circuit diagrams to be found in these magazines. Select the ones you want, enclose 30 cents in stamps for each one desired.

We advise immediate attention to this as the stock of back numbers of several issues already has been exhausted.

## May, 1922

—How to make a simple Crystal Set for \$6.

## October, 1922

—How to make a Tube Unit for \$23 to \$37.  
—How to make an Audio Frequency Amplifying Transformer.

## November, 1922

—Photo-electric Detector Tubes.  
—Design of a portable short-wave radio wavemeter.

## May, 1923

—How to make the Erla single-tube reflex receiver.  
—How to make a portable Reinartz set for summer use.

## June, 1923

—How to build the new Kaufman receiver.  
—What about your antenna?

## July, 1923

—The Grimes inverse duplex system.  
—How to read and follow symbols.  
—Proper antenna for tuning.

## September, 1923

—Simple Radio Frequency Receiver.

## December, 1923

—Building the Haynes Receiver.  
—Combined Amplifier and Loud Speaker.  
—A selective Crystal Receiver.

## January, 1924

—Tuning Out Interference—Wave Traps—Eliminators—Filters.  
The article which was announced from stations WJAZ, WOC and WOAW.  
—A Junior Super-Heterodyne.  
—Push-Pull Amplifier.  
—Rosenbloom Circuit.

## February, 1924

—How to make a battery charger.  
—Improved Reinartz Circuit.  
—Interference rejectors.  
—Single Tube Heterodyne.  
—How antenna functions.  
—Adding two audio stages to selective receiver which began as a crystal set.  
—Superdyne receiver.

## March, 1924

—An Eight-Tube Super-Heterodyne.  
—A simple, low loss tuner.  
—Junior Heterodyne Transformers.  
—A Tuned Radio Frequency Amplifier.  
—How to make the Kopprasch Receiver.  
—Adding Radio Frequency to the Variometer Set.  
—Simple Reflex Set.

## April, 1924

—An Efficient Super-Heterodyne (fully illustrated).  
—Selecting the Right Receiver.  
—A Ten-Dollar Receiver.  
—Anti-Body Capacity Hook-ups.  
—Radio Frequency Amplification.  
—Reflexing the Three-Circuit Tuner.  
—Index and first two instalments of Radio Age Data Sheets.

## May, 1924

—Construction of a Simple Portable Set.  
—An Ideal Set for the Summer Camper.  
—A Traveling Man's Receiver.  
—Radio Panels.  
—Making a Baset-Weave Tuner.  
—Third Instalment of Radio Age Data Sheets.

**RADIO AGE, Inc.**

500-510 North Dearborn Street

- . - . - .

CHICAGO, ILL.

# ZENITH

TRADE MARK

## Radio Companion

**A six-tube set completely self-contained! No need to open case to operate No exterior loop or antenna required**

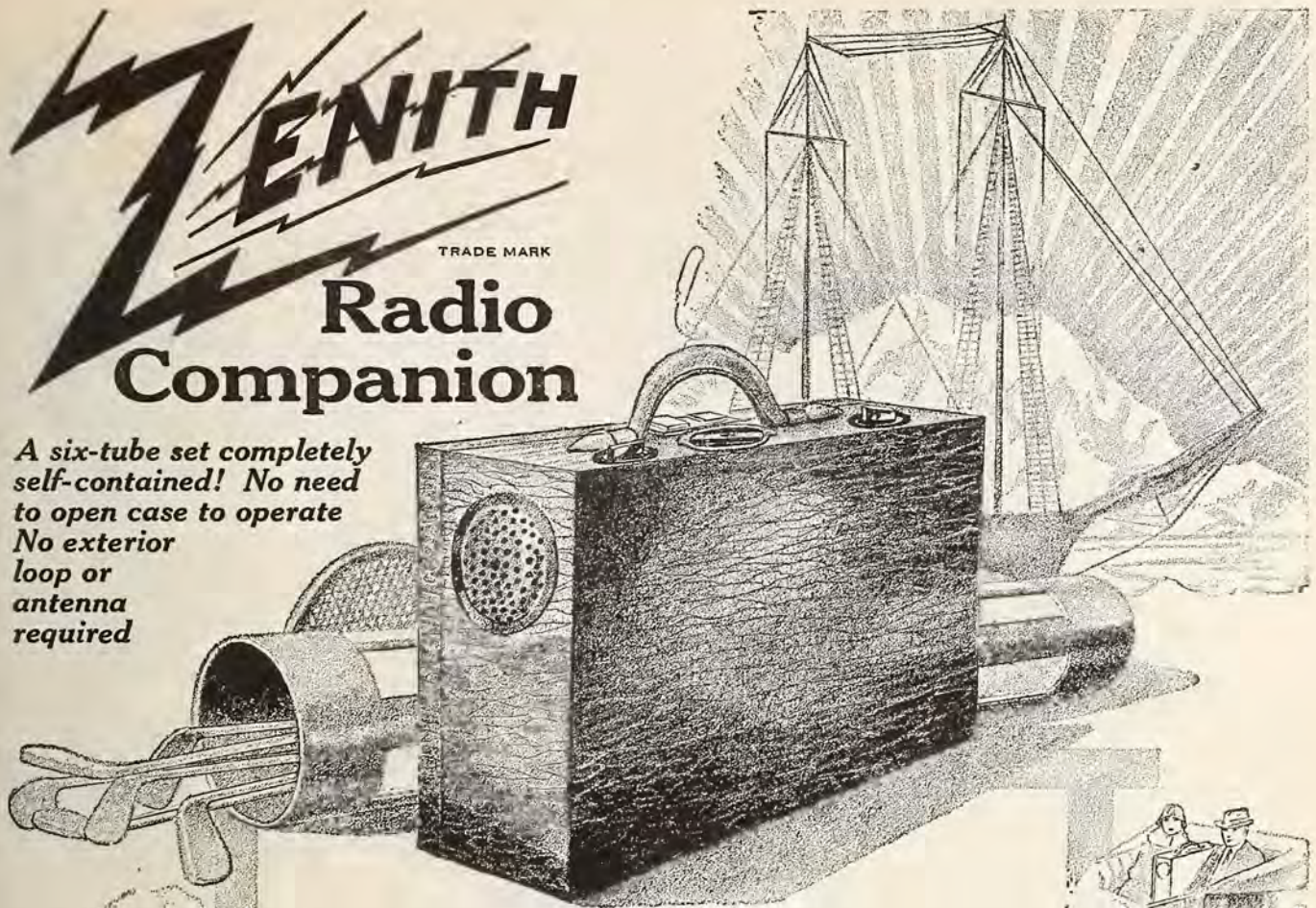

### Zenith — MacMillan's Choice Encased in a Light Traveling Bag!

Here's a six-tube radio set that's entirely self-contained—tubes, "A" batteries, "B" batteries, loud speaker and loop antenna complete, and it's a *Zenith!*

Packed into a small, beautifully finished traveling case—much smaller than the average suitcase—this new Zenith is the most compact set ever made giving clarity, quality, volume and distance.

Do you see those two little buttons close to the handle? Those are the controls. In order to operate the new Zenith Radio Companion you simply turn the controls to bring in the station you want—then for maximum volume you swing the case so that the loop is facing that particular station. You will be astonished at the clearness with which the music and the voices come through—and in what volume!

Think what it would mean to you to be able to take one of these new Zeniths with you on your travels and outings. A real radio set—the exclusive choice of Donald B. MacMillan for his Arctic expedition—yet so compact that it takes up no more space than a light traveling bag!

Think of the fun you could have with this set—the dance music you could listen to on moonlit nights—the orchestras that would play for you as you and your pals gathered round the camp fire—the com-

panionship it could give you on your motor parties—at the bathing beach. Picture the enjoyment it could bring your guests at the house-party or the weekend gathering.

Again, think how such a set would while away a lonesome evening in that dreary out-of-town hotel—what a god-send it would be to that invalid mother—to that dear relative or friend who must spend weeks and months in the hospital!

But if you have already been initiated into the wonders of the Zenith, you don't need to be told the extraordinary use you could get from this new model or the fun it could give you.

Just the knowledge that you could pick up this beautifully finished case—even as you would pick up your hand bag—and take it with you across city, country, lakes, mountains, and still turn those two controls and be able to listen at a moment's notice to the world you have left behind—that thought alone should be enough to suggest the infinite delights provided by this new Zenith Radio Companion.

You will want to know more of this remarkable set—so light and compact, so easy to operate, so wonderfully convenient. You will want to see it for yourself, at the very earliest moment. No ear-phones, you understand. No outside antenna. Yet clarity, volume, quality, distance! A real Zenith, packed into a traveling case!

Your name and address on the coupon, and the coupon placed in the mail, will bring you full particulars.



Listening, with the keenest pleasure, to music and voices in the elms they have left behind!



Lively orchestras entertain these boys, miles and miles from civilization.



Receiving the latest market reports, the latest news developments, with the aid of the Zenith Radio Companion.



The height of luxury—motoring to music!



When three is company at the bathing beach.



A constant source of entertainment and delight to the invalid.

**Zenith Radio Corporation**  
McCormick Building  
Chicago, Illinois

**ZENITH RADIO CORPORATION,**  
Dept. 2-F, 328 S. Michigan Ave., Chicago, Ill.

Gentlemen:

Please send me illustrated literature on Zenith Radio, including full particulars of the new Zenith Radio Companion.

Name.....

Address.....

# RADIO AGE

The Magazine of the Hour

Established March, 1922

Volume 3

JUNE, 1924

Number 6

## CONTENTS

	Page
Important Factors in the Construction of a Super-Heterodyne.....	5
By F. D. Pearne	
Automatic Filament Control.....	8
By Roscoe Bundy	
A Universal Amplifier.....	9
By Felix Anderson	
All Together for a Radio Summer.....	11
A Sure Fire Reflex Set.....	13
By R. J. Robbins	
Broadcaster Wins Copyright Suit.....	17
The Why of the Heterodyne.....	19
By John B. Rathbun	
Adding Radio and Audio to Baby Heterodyne....	21
By John B. Rathbun	
What the Broadcasters Are Doing.....	23
Radiotorials.....	25
Pickups and Hookups.....	27
By Our Readers	
Radio Age Data Sheets.....	37, 39
Radio Will Not Be Taxed.....	38
The Trouble Shooter.....	42
With the Manufacturers.....	46
Corrected List of Broadcasting Stations.....	50

Radio Age is published monthly by  
RADIO AGE, Inc.

Advertising, Editorial and Publication Offices,  
500 N. Dearborn St., Chicago

LOUIS L. LEVY, *Circulation Manager*  
FREDERICK SMITH, *Editor*  
FRANK D. PEARNE, *Technical Editor*  
M. B. SMITH, *Business Manager*

*Eastern Representatives*  
DAVIDSON & HEVEY  
17 West 42nd Street, New York City  
Telephone, Longacre 1698

Advertising forms close on the 15th of the month  
preceding date of issue

Applicants for membership in A. B. C.

Issued monthly. Vol. 3, No. 6. Subscription price, \$2.50 a year.

Entered as second-class matter April 4, 1924, at the post office at Chicago, Illinois, under the act of March 3, 1879.

Copyright, 1924, by RADIO AGE, Inc.

## A Chat With the Editor

WHILE there may be a slackening up of construction work during the hotter weeks of Summer, it is already quite evident as we go to press that the radio public is not losing its interest in reading about radio. It does not seem to require much training before the fan is able to get amusement and real instruction out of the mere studying of wiring diagrams. While the practice of one's knowledge of hook-ups may be temporarily suspended, there is still a deal of enjoyment in contemplating the theories.

That is why we are again offering, in this June number, a variety of technical articles with the usual helpful illustrations.

It is apparent that much of the public interest is centered on the super-heterodyne. This outfit, heretofore avoided by many because of the expense involved in purchasing a sufficient number of tubes and other accessories, is being simplified with a view to reducing the number of tubes needed. It is only a question of time when the super-heterodyne will be within the reach of the average fan, both as to cost and to construction and operation.

Meanwhile the regenerative, the Reinartz and several others of the standard circuits, such as the reflex, claim the attention of a vast number of home experimenters.

The old fable that something may be invented tomorrow that will make the receiver of today look like a wheelbarrow in an automobile show, is still popping up occasionally. Let us make the prediction that for a long time to come new developments in radio will find their birth in patient, deliberate experimentation. Radio is still an infant art, but Rome was not built in a day. We ask that you follow our writers in their discussions in future issues of the improvements and discoveries as they are made.

*Frederick Smith*

—Editor, RADIO AGE

"THE AIR IS FULL OF THINGS YOU SHOULDN'T MISS"



No. 7111  
Eveready  
"A" Dry Cell  
The best  
battery for use  
with dry cell  
tubes



No. 766 "B" Battery, 22 1/2 volts

## More Power for Summer Radio

When you take radio away with you—take Eveready Radio "A" and "B" Batteries, the batteries whose great power lasts longer. Remember, summer's the time when radio signals are weaker.

Batteries do get used up in time. The ones you've been using, though partly exhausted, may be satisfactory for the strong winter signals, but are probably inadequate for the weaker summer signals.

For instance, use the familiar standard 22 1/2-volt Eveready "B" Battery No. 766. It has variable taps for "soft" detector tubes. Put two, three or four in series to provide sufficient power for amplifiers.

To light the filaments of your dry cell vacuum tubes for the longest time, use Eveready Dry Cell Radio "A" Battery No. 7111. The Eveready "A" will astonish you by its long-sustained vigor. It is advisable to use two Eveready "A's" connected in

multiple for each WD-11 or WD-12 tube—this gives the economical "eighth" ampere drain per cell which insures maximum economy and longer life. For sets employing one to three UV-199 tubes use three Eveready Dry Cell Radio "A" Batteries No. 7111 connected in series.

The greatest electro-chemical laboratory known created these famous dry cell batteries on which radio largely depends. The experience of thirty years in battery making stands back of them.

Eveready Radio "A" and "B" Batteries—lively, peppy, long-lived producers of power.

For your light-weight sets to take camping or on hikes, Eveready has suitable small batteries.

Manufactured and guaranteed by  
NATIONAL CARBON COMPANY, INC., New York—San Francisco  
Headquarters for Radio Battery Information  
Canadian National Carbon Co., Limited, Toronto, Ontario

Informative and money-saving booklets on radio batteries sent free on request. If you have any questions regarding radio batteries, write to G. C. Furness, Manager, Radio Division, National Carbon Company, Inc., 202 Orton Street, Long Island City, N. Y.

Eveready  
6-volt  
Storage  
"A"  
Battery



No. 771  
"C" Battery



No. 763  
"B" Battery



No. 767  
"B" Battery



No. 764  
"B" Battery

# EVEREADY Radio Batteries

—they last longer

Always Mention RADIO AGE When Writing to Advertisers



Kadel &amp; Herbert Photo.

#### FIRST AID TO THE SHIPWRECKED

The S. S. "Columbus" is the first ocean liner to carry lifeboats fully equipped with radio receiving and transmitting equipment. The set shown above, a powerful one capable of receiving stations several thousand miles away, is placed under the prow. Officers are rigging and hauling up the antenna on one of two motor lifeboats equipped with radio.

# RADIO AGE

## The Magazine of the Hour

M. B. Smith  
Business Manager

A Monthly Publication  
Devoted to Practical  
Radio

Frederick A. Smith  
Editor

## Important Factors in the Construction of the Super-Heterodyne

By FRANK D. PEARNE

**A**LTHOUGH many new receiving sets have appeared during the last year and a half, some of which are claimed to pick up any station within a radius of three thousand miles, it is doubtful whether or not any of them can even begin to compare with the Super-Heterodyne. Ask any radio man of experience what he would suggest as the best possible set and invariably the answer will be, the super-heterodyne. It was this type of receiver that first made it possible to reach across the ocean and when properly constructed and operated, its performance has never been equalled, this fact having won for it the title of "king of them all."

Just why should this arrangement be so far ahead of everything else of its kind? It is not new, but it is only within the last year that its real value has been appreciated, but one reason for its sudden popularity is the fact that its construction is based upon good sound logic, but while it has never met its peer, it must be remembered that in order that it may produce the remarkable results which are claimed for it, the greatest of care must be exercised in its construction and even when this is done one must not expect to learn to handle it as easily as he can operate other receivers.

The operation of this receiver is an art and will require considerable patience on the part of the operator before he will be able to tune it quickly and sharply to any desired wave. When playing with the dials, even the most unsophisticated amateur cannot help but realize that he has before him something very unusual, for he will hear every thing known to broadcast programs as the dials are moved slowly around, but to select and bring in any particular one of them is a different story. They are all there and with them is a strange collection of sounds and noises such as he never heard before, and it will take time and patience to learn just how to bring them in loud and clear and to lose the weird sounds that seem to accompany the programs. When by constant practice and study, he gets so far advanced that he can bring in just what

he wants, and that only, he stops experimenting on receivers, for he has reached the top of radio reception.

Because of the apparent expense involved in the construction of the super-heterodyne many of the old timers have hesitated about building it, but when the whole thing is boiled down to just what is

the building of a super-heterodyne set, claiming that they would not work, but whether this is caused by the assembly of parts which are not well suited for each other, or whether some of the manufacturers are not careful enough in the selection of these parts, is a question and it is in the hope of clearing up some of this trouble that the following specifications are given.

### How the Super-Heterodyne Works

Distant reception is best accomplished by the use of radio frequency amplification, used before the signal is detected. By using several stages of this type of amplification ahead of the detector, it is possible, according to theory, to pick up very weak signals from great distances and so amplify them before detection that they can be heard as well as local stations. This theory would work out very nicely if all the broadcast waves had the same frequency, but unfortunately this would make it impossible to tune in any particular one, and as any radio frequency transformer, such as is used in this type of amplification, will have one particular frequency at which it will operate at its greatest efficiency, then it may be readily seen that one certain station sending out waves at just the particular frequency best suited to the type of radio frequency used would be heard with remarkable clearness and volume and all the rest of the stations using waves of different frequencies would come in poorly.

Now the super-heterodyne, as will be explained later, consists of a method of changing the frequency of any incoming wave to that best suited to the radio frequency transformers used. That is, the signals, no matter at what frequency they come in, are changed in any case to one common frequency, so that any of them selected will always pass through the radio frequency transformers at the same frequency, which is that at which they function at their greatest efficiency. This is called the intermediate frequency. It has been found that these intermediate frequencies should be those of much greater wave length than those for which

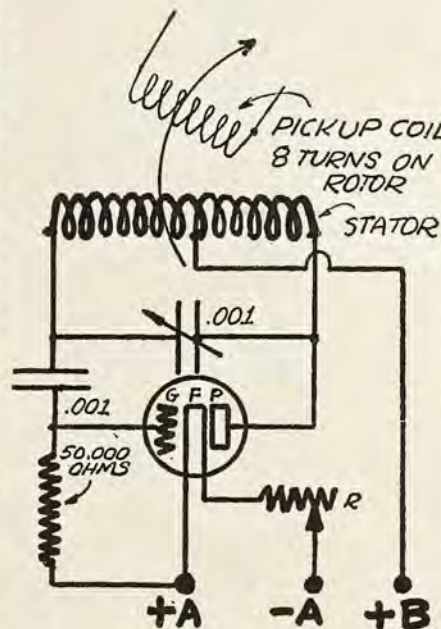

Figure 2. A diagram of the Hartley Oscillator.

actually needed in the way of apparatus, much of it can be made at home with ordinary tools and in many cases this home made apparatus will give better results than factory made parts. The object of this article is not, however, to describe the construction of the set, but rather to explain the action of some of the most important parts, so that the builder may know exactly what he is doing. Numerous complaints have been received from our readers who have purchased parts for





cycles, or 383 meters, as the difference between the two will still be 50,000 cycles, or 6,000 meters.

From this process it will be seen that no matter what the fundamental wave length of the radio frequency transformers may be, or what the length of the incoming wave may be, it is possible, by the adjustment of the frequency of the local oscillator, to form a combination frequency which will be suitable for the particular radio frequency transformers used. In this way then it is possible to use radio frequency transformers which respond perfectly to only one particular frequency, and by means of the oscillator to change any incoming wave to this frequency. Thus it is possible to get the maximum efficiency from these transformers, no matter what may be the length of the incoming wave.

There are several different methods of constructing an oscillator and there are also many different ways of connecting the pickup coil, but as that shown in Figure 1 is found to be very effective, I am using it to show how the oscillator and the radio frequency transformers are connected.

### Construction of the Oscillator

One of the greatest difficulties encountered in the construction of the super-heterodyne receiver is to get an oscillator which will oscillate freely over a wide band of wave lengths, and much of the trouble experienced in the construction of a set of this kind is caused by a poor oscillator. In cases where the intermediate frequency (that of the radio frequency transformers) is set at 3,000 meters, the oscillator should be designed to cover a range of from 214 to 750 meters.

This will require a variable condenser having a capacity of .00083 to .001 M.F. connected across an inductance of 155 microhenries. For intermediate wave length of 6,000 meters, the oscillator will have to cover a range of from 207 to 666 meters, which will require a variable condenser ranging from .00097 to .001 M.F. in combination with an inductance of 124 microhenries.

Where intermediate wave length of 10,000 meters is to be used, the variable condenser should have a range of from .001 to .001 M.F. and the inductance should be 110 microhenries. Most any of the capacities mentioned may be obtained with a good 43 plate variable vernier condenser and means for obtaining the proper inductance will be explained later.

These values are found mathematically. For example, the 3,000 intermediate frequency requires wave lengths ranging from 214 to 750 meters. The 214 meter wave has a frequency of 1,400,000 cycles and the 3,000 meter wave (the intermediate) has a frequency of 100,000 cycles. Subtracting this 100,000 from 1,500,000, which is the frequency of a 200 meter wave and is the lowest used, we get 1,400,000 cycles, which is a wave length of 214 meters, which is found by dividing 300,000,000 (the speed of electricity) by 1,400,000. The high wave length range

(Continued on page 36)



Kadel & Herbert Photo.

### ENTERTAINMENT WHILE YOU WORK

That's the idea of "Blind George" Wittenberg, newsdealer at Forty-second Street and Sixtieth Avenue, New York City. He combines his business with pleasure by listening to serious discourses while he waits upon his customers. And although George is blind he can still see the advantages of having RADIO AGE within easy reach on his stand.

### De Forest Wins Radio Fight

Dr. Lee De Forest, eminent scientist and "daddy of the radio," was declared to be the originator and sole inventor of the "feed back" and regenerative circuits in a ruling handed down recently by the United States Court of Appeals in the District of Columbia.

The decision, rendered by Chief Justice Smyth, with the associate justices concurring, ends litigation and innumerable suits which have dragged through the courts for more than seven years. Because of their importance the suits have attracted world-wide attention.

### Four Claimed Invention

Four men, each claiming the invention, were directly interested and entangled in the suits. They are Doctor De Forest, inventor of the audion; Dr. Irving Langmuir, of the General Electric Company; Dr. A. Meissner, German radio expert, and Maj. Edwin H. Armstrong. Five separate actions with each of these men either as defendants or plaintiffs were directly disposed of by the decision.

The case which brought the final decision was brought by Doctors De Forest, Langmuir and Meissner from the decision of the Commissioner of Patents, who had

awarded priority to the invention to Armstrong.

"The whole case," says the decision, "turns upon the question of priority to be determined solely as a question of fact. The Commissioner of Patents, affirming a decision by the Board of Examiners-in-Chief, awarded priority to Armstrong.

"We have no doubt but what Armstrong produced the invention at the time alleged. But his earliest claim to a conception of his invention in October, 1912, followed by a witnessed sketch on January 31, 1913. This date antedates any time claimed by or available to either Meissner or Langmuir and therefore eliminates them from further consideration.

### Notes Reveal Discovery

"It is clearly shown that De Forest was developing the idea involved in this invention in the early part of 1912. It appears from his book-notes that the first discovery of the feed-back circuit occurred in connection with his work on the amplifier.

"There is some testimony prior to August, 1912, that the oscillating properties of the audion were discovered by De Forest. The decisions of the Commissioner are reversed and a priority awarded to De Forest."

# Automatic Filament Control

By ROSCOE BUNDY

**C**ONTROL of the filament current and electron emission by means of a manually operated rheostat is as old as the vacuum tube, and with the exception of a few minor refinements in the general design of the rheostat there has been but little attempt at improvement in this part of the circuit. This lack of interest in what is really one of the most important functions of the radio receiver seems strange when one considers the close attention that has been paid to the development of the other apparatus used.

The electron stream issuing from the heated filament surface is the carrier of the radio impulses passing through the tube, and represents the relaying energy supplied by the local battery. For this reason the amplification of the tube is in rough proportion to the quantity of electrons emitted by the filament, and as the emission is roughly proportional to the filament temperature it is evident that the filament current control is of vital importance. Every tube develops its maximum economical electron emission at a given voltage across the filament circuit. If this voltage is much exceeded, then the filament current will cause some additional amplification but at the cost of a marked reduction in the useful life of the tube. With a voltage lower than normal, the emission will be reduced and the amplification will suffer to a corresponding degree.

Unless a voltmeter is attached to each receiving set, as is very frequently done with the large and expensive Super-Heterodynes, it is almost certain that voltage control will be uncertain and that either the life of the tubes or the amplification will be reduced below the normal mark set by the maker of the tubes. Unguided hand control is both wasteful and annoying in the operation of amplifier tubes. The ideal condition for the operation of amplifier tubes is met with in an automatic device which will maintain the constant rated voltage across the filament regardless of fluctuations in the battery voltage, all without the attention of the operator.

With the large multi-tube receiving sets of the present day, such as the neutrodyne and Super-Heterodyne, the control of from four to six amplifying tubes is quite a problem. All of the tubes connected in one series must give equal electron emission for maximum amplification and this is hardly possible when the tubes are controlled separately by manually operated rheostats or even when the bank of tubes is operated from a single rheostat. Individual regulation depending upon the judgment of the operator is the height of uncertainty. With the tubes operated from a common rheostat, there will be a difference in potential across the filament of each tube due to the voltage drop in the line, the voltage being lower at the tube farthest from the rheostat than at the tube next to the variable resistance.

Individual control of the tubes is desirable only if the control is automatic.

Still another item in the economical operation of the tubes is that of carelessness in handling a manually controlled rheostat, or the use of a battery switch if one is installed. On multi-tube sets it is the common practice to leave the rheostats of the amplifying stages in their normal "on" position after pulling the battery switch, and this means that the filaments will be subjected to an excessive current flow for several seconds after the battery switch is again snapped on, for the cold rheostat will not present its full resistance until it has been warmed up by several seconds of current flow. During this time, the filaments receive abuse which in the course of time will make a marked reduction in their life. Again, we frequently find that the rheostats have been unintentionally turned full on by inquisitive persons monkeying with the sets, and again the tubes receive a jolt when the switch is snapped on.

Probably the most noteworthy attempt at automatic filament control for amplifier tubes is met with in the "Amperites" manufactured by the Radiall Company.

These are small cartridge like resistance units which remind one of the usual tubular grid leak and are mounted on small springclip bases much like the tubular leak type. One of the Amperites is placed in series with each of the tube filament lines, just as with the ordinary rheostats, and by the properties of the resistance unit the filament current flow is held at a constant value regardless of the voltage fluctuations of the battery. Fully charged or discharged, the battery voltage makes no difference in the potential across the filaments until the battery voltage is finally allowed to drop below the normal voltage rating of the tube.

Practical tests with these little automatic rheostats showed that the tubes were held at the proper voltage through a wide range of battery charge conditions, and that all of the tubes in the bank were delivering their maximum output. As an additional advantage, there were no amplifier rheostat knobs on the panel and the wiring was very much simplified. Instead of fussing around with the rheostat knobs and lifting the cover of the cabinet to watch the filaments, one can confine their attention to the tuning controls.



OFTEN HEARD BUT SELDOM SEEN

These are the "faces that go with the voices" from Station WGY, the Schenectady station of the General Electric Company. These popular announcers are, from left to right, front row: Robert Weidaw, Kolin Hager, chief announcer; Carl Jester; back row, William Fay, Asa O. Coggeshall and Edward H. Smith.

# A Universal Amplifier

By FELIX ANDERSON

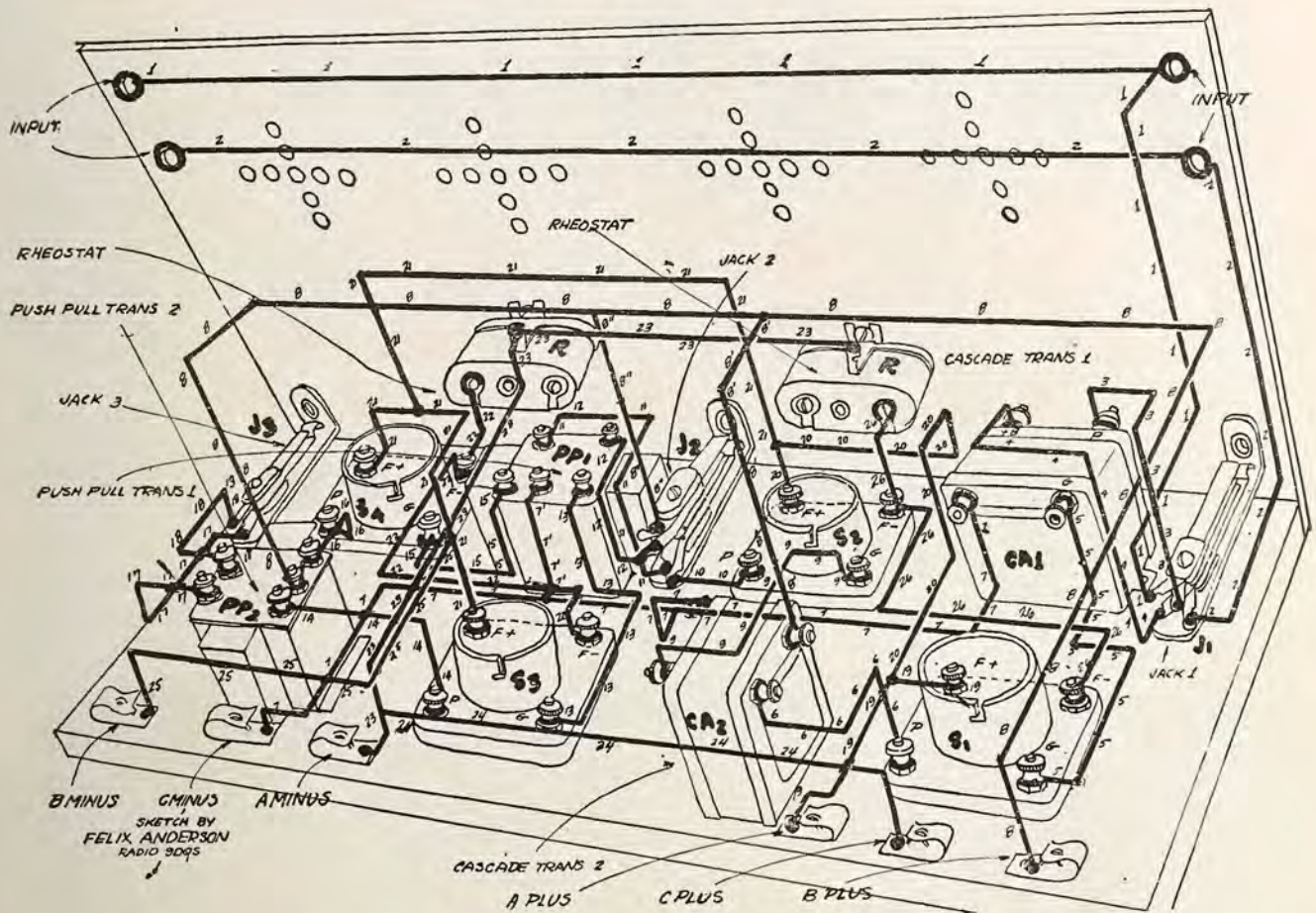

Figure 3. An isometric sketch of the improved amplifier with wires numbered to correspond with the circuit diagram of Figure 4.

RECENTLY the writer has noted a tremendous demand for receivers of the improved type. Readers have repeatedly sent in requests asking how their one-tube receivers may be improved. In their questions they request us to specify whether radio frequency or audio frequency shall be used, and in some cases both are advised; some only audio or radio, and some neither. This depends entirely upon the type of circuit used.

With the idea in mind of designing a unit that could be used effectively on any type of receiver, the writer decided that the majority of the simple circuits would not profit by a radio frequency amplifying unit, and therefore devoted his attention toward designing a unit that would be compact, inexpensive, efficient, and which could be used to advantage with practically any type of receiver.

### Portables for Vacations

With the advent of Summer, one also has to consider that there will be many portable sets constructed which will be taken on vacation journeys and jaunts. On returning to the summer cottages or

homes these small compact portable receivers will lose their usefulness inasmuch as their signals are not loud enough to be used to entertain a large gathering.

The writer decided, therefore, that it would be a good idea to show readers how to construct a unit that could be connected to either a portable or a home receiver, and which would produce signals of sufficient intensity to be used on the same basis as the phonograph; for dancing and general entertainment.

Returning to our original subject, the demand for improvements on receivers has been very great and we therefore recommend that experimenters who care to improve their present sets consider the construction of a unit of this type.

The improved Cockaday is probably the most convincing argument in this behalf.

### The Unit

The unit which I am about to describe consists of two stages of cascade audio frequency amplification which uses the tubes in the ordinary manner of connecting up the two-stage amplifier. The remaining tubes are used as a third stage of amplification employing the balanced

amplifying circuit more commonly known as push-pull amplification.

The merits of using the balanced amplifier for a third stage were discussed in detail in the January, 1924, number, where the separate unit of this type was described. Briefly, its advantage lies in the fact that the two tubes are practically used to do the work of one, which results in more efficient action on the part of the valves and transformers and produces a signal of great audibility without the customary squeals, distortions and noises which accompany amplifiers in the third stage when connected in cascade.

The expense involved in such a unit is not very great when one considers the quality, amount, and nature of the signals produced.

### Construction

First of all, the parts required for the unit are as follows:

- 1 panel, 7x14 inches.
- 1 cabinet, 7x14 inches.
- 1 mounting board.

(Continued on page 16.)

(Diagrams on next page.)

# Amplifying Unit for Any Type of Receiver

(Continued from preceding page.)

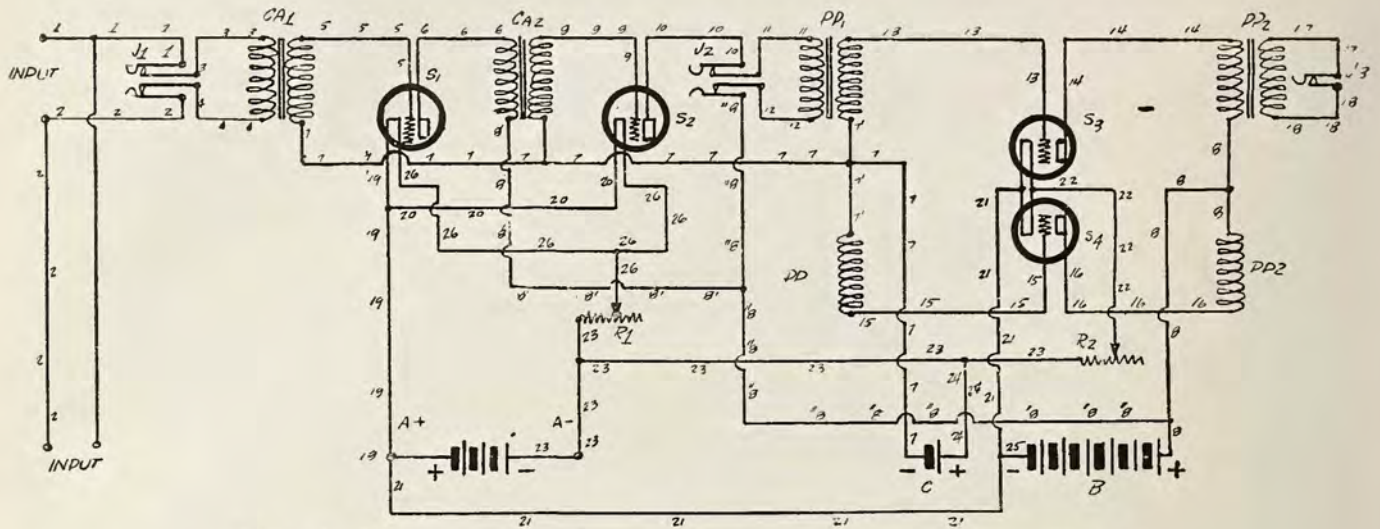

Figure 4. Connections on the above cut correspond with the numbering on Figure 3.

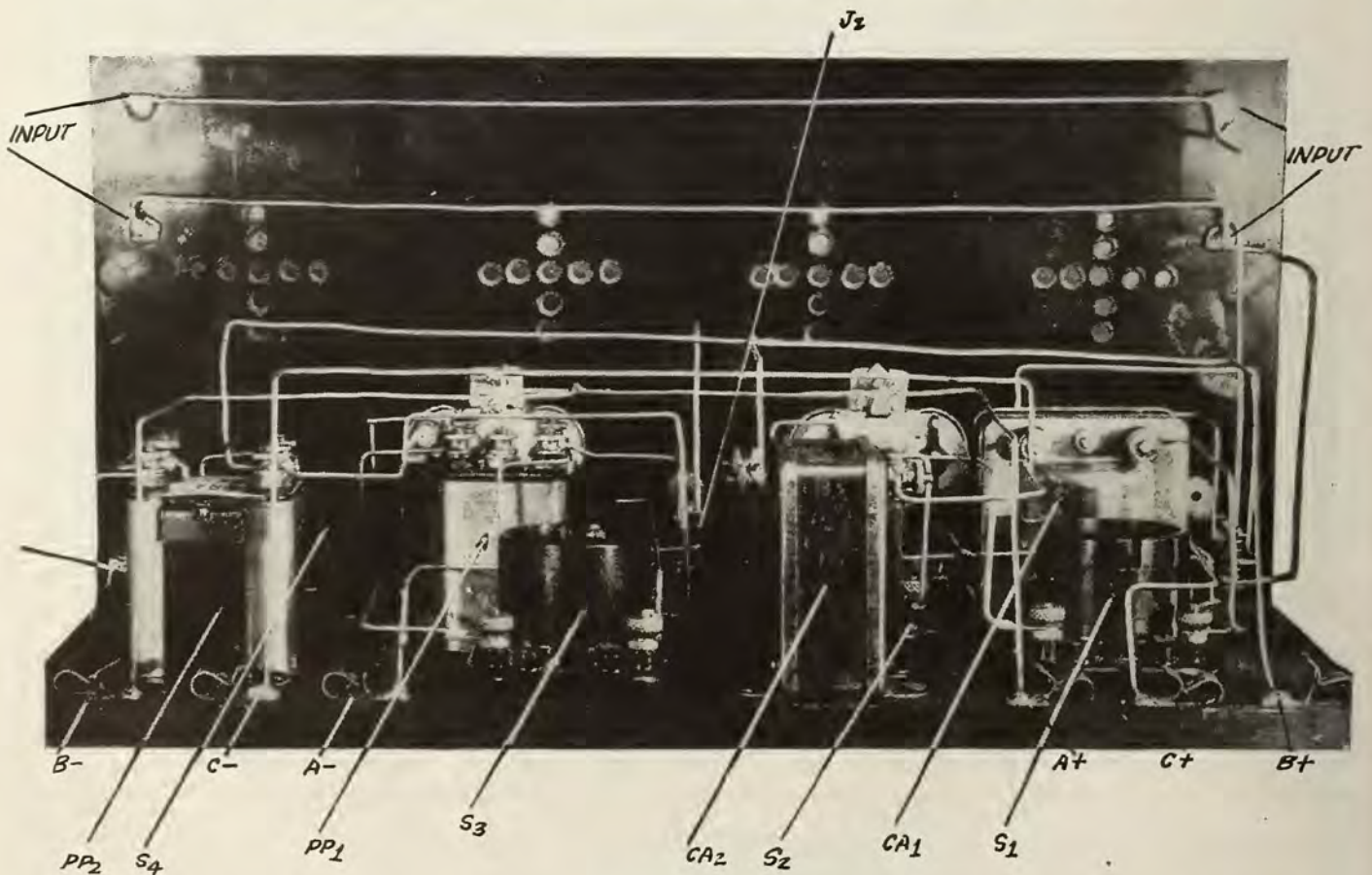

Figure 5. A back view of the amplifier described in the text on pages 9, 10 and 16. The lettering refers to the following parts: PP1 and PP2 the push-pull transformers, S 1, 2, 3 and 4 the tube sockets, J 2 the jack for the cascade amplifiers, CA 1 and 2 the cascade transformers, and the binding posts which are marked according to their respective polarities. This unit can be used effectively with any type of receiver, and will deliver signals of great intensity when properly constructed and operated. Two sets of input binding posts are used, making it possible to use the unit with either right or left handed receivers.

(This article continued on page 16.)

# All Together for a Radio Summer

## 1924 to Be Most Popular Season

**T**HE Summer of 1924 is destined to be the greatest "radio Summer" since broadcasting was begun, as a result of extensive plans and programs just completed by leading broadcasting stations throughout the country, as well as manufacturers of radio apparatus.

A nation-wide survey has disclosed that at no previous time has the radio industry been so geared to give a higher standard of service to the radio public. Reports from manufacturers, distributors, amateurs' organizations and other factors in the industry indicate a general movement to bring radio out into the sunshine during the Summer months.

### Conventions "On Air"

Probably the great Summer-time event on the season's schedule is the Democratic national convention in New York City this month and the Republican national convention in Cleveland. These great gatherings will put the "fan" in the thick of the pre-election campaign and for the first time in history millions of people will be able to "attend" the national conventions.

The listeners-in will be able to follow each political issue as it is fought out on the convention floor; they will hear the nomination speeches of "favorite sons";

the thunder of applause for popular candidates—the music, the clamor and the excitement of the impromptu parades which will spring up from time to time on the convention floors. Elaborate arrangements are being made so that the largest possible radio audience may be able to listen in on these conventions.

Immediately after the conventions will come the Presidential election campaigns, in which radio again will play an epochal part, for nearly every candidate intends to broadcast his appeal to the electorate through the air.

### Increase In "B" Stations

Because there are more Class B high-powered broadcasting stations in operation this year than during 1923, reception during the hottest Summer months will be vastly better than ever before. The new allocation of wave lengths, especially among the higher powered stations, is expected to eliminate much of the interference resulting from conflicting wave lengths.

Most of the great sporting classics and outdoor events scheduled for 1924 will be held during day-time, thus assuring clarity of reception. Also, such events offer another reason for the anticipated increase

in popularity radio will enjoy this Summer.

Manufacturers of radio products point out that because of the vast improvement in radio apparatus during the past year, the varied programs from many broadcasting centers will be received with great satisfaction by millions of radio "fans" throughout the country.

With 591 broadcasting stations to select from this Summer, no town or hamlet in the country will be without a suitable program during the sultry days. Changes in antenna and aerial systems have increased the radiation efficiency of many stations.

### Broadcasters to Join

The broadcasters especially are doing their "bit" to make 1924 a successful radio Summer. Inter-connecting systems of radio broadcasting, whereby important stations will join for the simultaneous broadcasting of outstanding events, will insure the clear and adequate reception of the many messages of national importance now being planned.

The uses of radio during Summer-time are unlimited. Besides being a fascinating pastime during the long Winter months, radio reception will be a boon to those



NOW A FLAT TIRE IS A PLEASURE

Kadel & Herbert Photo.

For while she's waiting for someone to come along and change the tire, our lady vacationist can tune in on her faithful set and be entertained from distant cities. Radio has become so popular that vacationists and tourists this year are planning to take their sets along to help idle away the Summer hours. The scene above was snapped in the vicinity of Washington, D. C., and shows a radio enthusiast experimenting with a super-heterodyne with which no aerial or ground is needed.

who have vacation thoughts for Summer.

Radio can be quickly made a permanent part of every seashore home; the mountain home or lodge; the camp; the automobile on tour; the farm catering to Summer boarders and the motor boat or canoe with facilities for a portable receiving set.

Any of these places can easily be equipped with a radio set, for they are never so far away from the nearest broadcasting station that good results cannot be obtained. Portable sets, which can be transported from place to place and set up in a few moments, are expected to be extraordinarily popular this Summer.

### Radio Everywhere

Summer resorts already are advertising radio as one of their special advantages for the vacation months. All this forecast of expected conditions indicates that no matter where a "fan" travels this year, he can always have his faithful friend, radio, within easy reach.

The baseball fan will be able to follow his favorite team no matter where he goes. Every station of importance is arranging to broadcast the baseball scores in all the leagues. Several boxing events, ending with a championship bout between Jack Dempsey and Harry Wills in the late Summer, will be carried through the ether to millions of eager listeners.

A comprehensive list of suggestions for the summer-time radio fan, with latest pictures and diagrams, will be published in the RADIO AGE for July. Watch for it.

## Radio Conference Planned

Secretary of Commerce Hoover will call a general radio conference in Washington soon after the adjournment of Congress in an effort to secure co-operation of all radio interests in clearing up the ether and solving the problem of distributing wave lengths. A conference will be called whether or not new legislation is enacted.

The conference will be similar to those in the Springs of 1922 and 1923, at which representatives of the manufacturers, broadcasters, engineers, amateurs, commercial operators, and broadcast listeners aided in drawing up voluntary regulations under which radio has been supervised ever since. It was in this manner that the distribution of wave lengths for broadcasters and other interests was developed.

Present indications are that broadcasting stations will continue to increase.

although wave lengths available for this use are practically exhausted and stations are doubling up. Even time allotments in congested sections are becoming difficult to make.

Secretary Hoover believes congested conditions and interference are not improving.

If the White bill is enacted, Secretary Hoover pointed out, new regulations and probably re-allocations of wave lengths will have to be made, and if no legislation is passed this will still be the case; otherwise a condition such as prevailed two years ago would confront the radio public.

### Thousands in "Radio Church"

The voices of clergymen in Schenectady, N. Y., which for years have been limited to the confines of their churches, are now carried to all parts of the North American continent by radio.



Kadel & Herbert Photo.

### BROADCASTING FROM THE CLOUDS

The newest feature of broadcasting has been adopted by army fliers. Under the direction of Major George Vaughn, 27th Air Service of the New York National Guard, former aces are now piloting airplanes and broadcasting interesting talks on army life while their machines speed through the sky. Each radio plane covers a specified territory and is equipped with a five-tube army transmitting set, which makes the new innovation possible. The picture shows Captain Brower, former war ace, piloting a Curtiss plane while a radio engineer is talking into the transmitter.

Every Sunday the services of the many churches in Schenectady are attended by two congregations; one visible to the pastor and the other that unseen but appreciative audience of radio devotees.

### Sermons Go Everywhere

Religious services have been a regular part of WGY's programs for several months, in co-operation with the Schenectady Ministerial Association. The messages of the clergy have reached especially to the thinly populated districts of Northern New York, New Hampshire, Vermont and Canada.

All of the ministers report the daily receipt of letters of appreciation from the listeners. Frequently they contain sums of money, which in many cases are set aside as mission funds. The most enthusiastic praise has been received from woodsmen, farmers, forest rangers, keepers of light ships and others in isolated regions.

# A Sure Fire Reflex Set

By R. J. ROBBINS

IT HAS been my sad experience that there are many so-called reflex hook-ups printed for which great claims were made. The ones which intrigued my interest mostly, however, were the one-tube sets which were widely advertised to work a loud speaker, but which I, frankly, have not been able to duplicate in practice. At the beginning of this description of my latest pet circuit I will be pardoned if I remark that this set will *not* work a loud speaker in my town on *anything* except the local broadcaster. Nevertheless, it will satisfy the most hardened BCL for tone quality, distance and volume. The circuit used is an old standby that is known to every BCL or Ham and was selected from several as the most promising of all. The general layout and method of tuning may be of interest, and it is hoped that a few of the DT's will try it out. I can promise entire satisfaction if all instructions are faithfully carried out.

## Materials Needed

- 1 panel condensite celoron or radion, 10x10x $\frac{3}{16}$  inches.
- 1 panel for shelf celoron or radion, 8x5 $\frac{1}{2}$ x $\frac{3}{16}$  inches.
- 1 potentiometer, 400 ohms.
- 1 rheostat, 30 ohms.
- 1 good socket (do not substitute).
- 1 neutroformer.
- 1 4-inch dial.
- 1 piece angle brass,  $\frac{1}{2}$ x $\frac{1}{2}$ x7 inches.
- 1 jack (double circuit if audio amplifier to be used).
- 1 crystal detector.
- 1 audio transformer.
- 1 Acme R-2 R. F. transformer.
- 4 binding posts.
- 3 mica fixed condensers, .002, .006, .001 M. F.

## Layout of the Panel and Shelf

The dimensions given for the panel and shelf are not in conformity with the standard sizes now furnished by most manufacturers, although the writer knows of at least one who carried the 10x10-inch size fairly recently. The layout for the panel with all necessary dimensions and indications of operations to be performed is shown in *Fig. 3*, while *Figs. 1 and 2* represent the front and rear views, respectively, of the assembled set.

The various holes are first laid out carefully. The only part of the work which should present any difficulty will be the sight holes for the bulb and the mounting screws for the neutroformer. The centers for all of these holes should all be located carefully by means of the compasses and all intersections of lines at correct points should then be deeply punched to center the drill.

All holes should be started with a small size drill to insure accuracy. These are then "chased" with increasingly larger sizes until all are of the sizes specified in plan.

The same procedure is carried out in regard to the shelf, which is shown in *Fig. 4*. If other parts than those specified are to be substituted some of these figures will probably have to be altered, but this is left to the individual who builds the set. In the case of the Acme R. F. transformer substitution is not advised, as a great deal of the success of the set will depend on this feature alone.

## Assembly of the Set

The use of the neutroformer provides a novel tuner which has thus far proved very satisfactory. The aperiodic primary winding eliminates the necessity for switches and taps in the antenna circuit, thereby boiling down the total adjustments of the set to four—if the crystal detector may be classed thus.

The shelf is first mounted in place by means of the 7-inch length of angle brass drilled off as shown in *Fig. 5* and held to the front panel and shelf by means of flathead brass 8-32 machine screws and nuts.

The neutroformer comes next, being

mounted by means of long 8-32 flathead brass machine screws and check nuts in such manner that it is spaced back from the panel about  $\frac{1}{2}$  inch. If this combination is used a very efficient tuning unit is assured and the front appearance will be found to be quite effective. It will be noted that the edge of dial comes directly in line with one of the mounting screws which support the shelf. This was intentional design and offers a very handy index for the dial if the slot in the screw is left in a vertical position to line up properly with the dial divisions.

The rheostat, potentiometer, jack, antenna and ground binding posts are now put in place, particular care being taken in the case of the first two named that binding posts face upward. The potentiometer should be on the side facing the ground lead, thus insuring short connections. The crystal detector occupies the space to the right of the dial in the two holes provided for it. This completes the assembly of the panel.

The balance of the work is soon accomplished. The socket is mounted in the

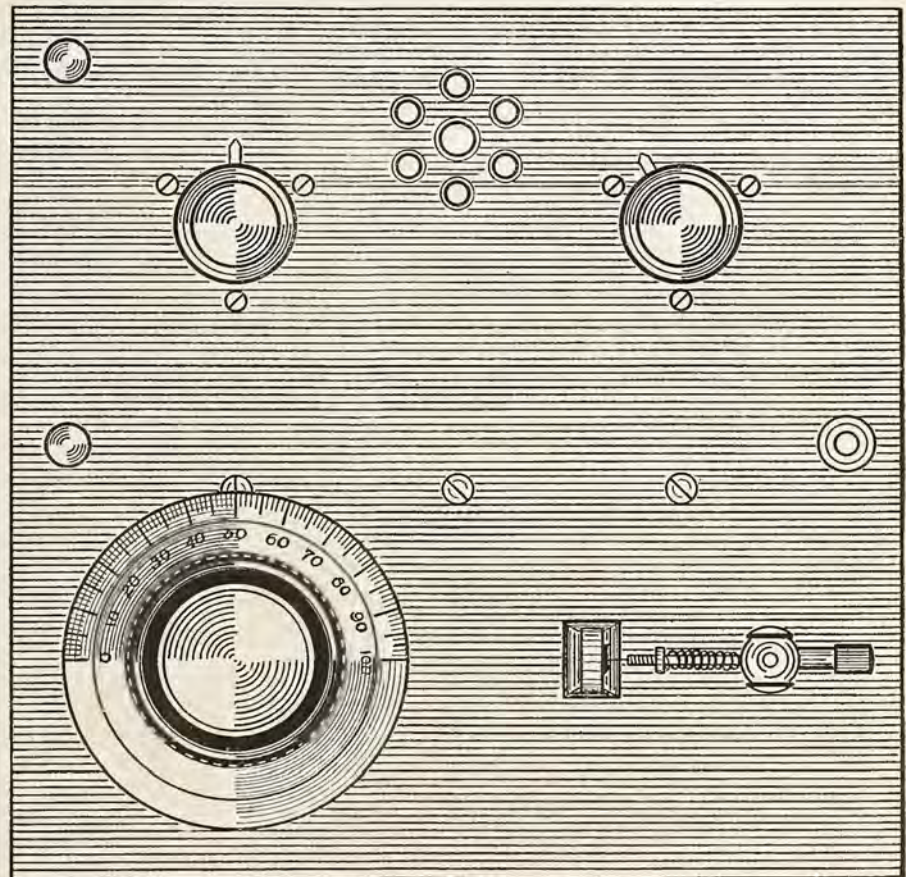

Figure 1. A front panel elevation of the Simple Sure Fire Reflex Receiver. There are only three major controls, two of which require but little attention while tuning. The dial in the upper left-hand corner is the potentiometer, immediately to the right are the peep holes for the tube, and next is the rheostat. Directly below the potentiometer is the tuning condenser and to the right is the crystal detector. A phone jack is shown directly to the right and above the crystal detector.

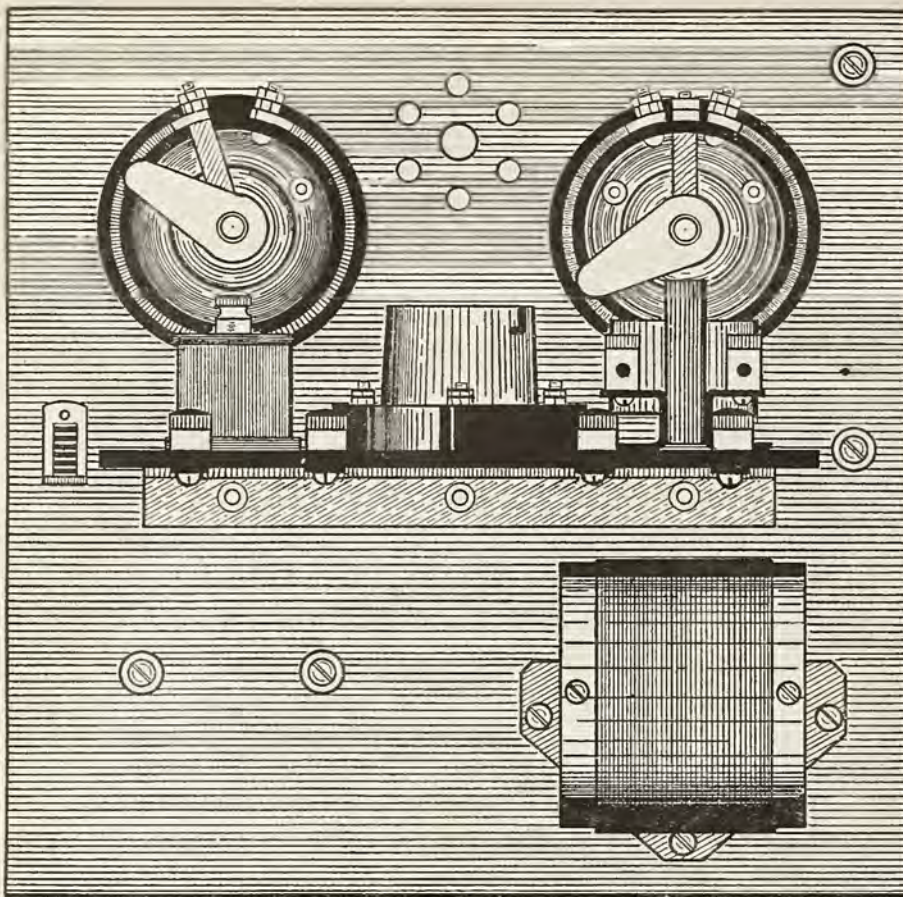

Figure 2. The back panel layout of the simple Sure Fire Reflex Receiver.

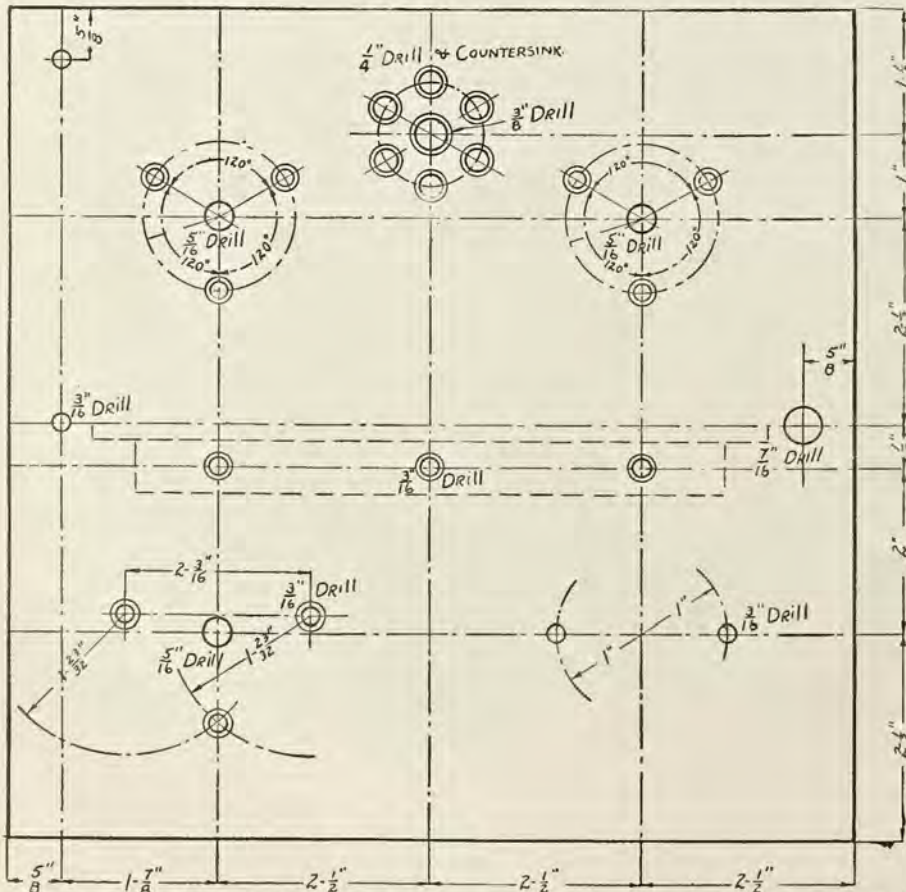

Figure 3. Template, drilling and layout instructions for the simple reflex described in the accompanying article.

center of the shelf in the position shown. Care should be taken that the posts marked G and P be left facing the rear, which will make for the shortest possible leads. The R. F. transformer is then put in place to the left of the socket and the audio transformer to the right. This places it close to the grid, which is desirable, while the plate leads are equally short to the R. F. transformer and B battery posts. The binding posts are the last to be put in place.

This completes the assembly work on the set, and we are ready to commence the last stage of the work, namely, the wiring. To some this work is the bugaboo of making a set, but there are comparatively few wires in this set, and this should present little difficulty even to an inexperienced worker.

#### Wiring of the Reflex

The writer may horrify certain of the radio fraternity who have fixed ideas as regards methods of wiring and soldering connections. The first blow will be dealt to those who use rosin. Many use this stuff and apparently get away with it, but here is one experienced radio man who says that the stuff is better to oil up fiddle bows with. The tinsmith doubtless will find it very serviceable in his profession, but it is not good for this work. I just had the pleasure of tearing down a perfectly nice job which had been done on a five-tube Neutrodyne which refused to utter a whimper. The root of the trouble proved to be the *non-corrosive* rosin which occupied every bit of space it could find in the interstices between the soldering lugs and binding posts. This formed a nicely *insulated* joint which would not pass storage battery current in some cases. In passing may I mention that I do not use an excessive amount of flux or solder on any joint, yet the above trouble developed after considerable precaution had been exercised. The cure was found in the use of muriatic acid cut with zinc and used very sparingly with plenty of heat to each joint. Do not be content until the solder runs bright and flows evenly over the wire.

In the case of binding posts it will be found more effective not to use soldering lugs at all, but make connections direct with the wire itself by making neat bends in it with the pliers and gripping with the posts. Do not solder to a post, as this procedure is unnecessary and makes disassembling of the set more difficult if this should prove necessary.

Keep all wiring widely spaced and run plate and grid wires at right angles if any come near each other. Try to figure the shortest possible route for each wire to run and keep all lines parallel by making neat bends of 90 degrees whenever a wire has to change direction. After wire is all in place connect in the three fixed condensers at points indicated and set is ready to try out. At this time it would be well to provide a suitable cabinet. This may be of oak, mahogany, birch or any wood preferred by the builder and should be given a good finish, as the set will present a fine appearance if properly enclosed.



**Some Hints for Operating**

This set will be found to give best results with UV201A tubes, although the UV199's may be used if the proper socket is used originally. Do not use adapters, as too much energy is lost in these make-shift arrangements. Short, direct leads and good connections go far to insure success with a reflex set. Insulation is of paramount importance and the writer advises against anything but a solid rubber socket or one made entirely of bakelite or similar material. This feature alone has spelled doom to success for many. Those with metal ferrules especially are to be avoided, as undesirable capacity effects are too often introduced in such sockets. Quite often we hear of some person who has a set employing one or two stages of R. F. amplification bulb detector and additional tubes for audio. He employs sockets such as were mentioned above and very often finds that his bulb detector will rectify perfectly without grid condenser or leak. As a matter of fact, the poor insulation between terminals is responsible for these results in a great many cases and his tube is no different from scores of others which ordinarily perform in normal style. For a set of this kind the oft despised porcelain sockets which have been placed on the market by several courageous manufacturers should yield very good results and may be classed favorably with the all-rubber or all-bakelite sockets mentioned before.

When all is ready connect the A and B batteries to the proper binding posts and light the bulb by turning up the rheostat. A pronounced click in the phones should be heard when the plug is pushed into the jack, indicating that the plate circuit has been connected up correctly. If there is no stray leakage at any point no music, signals or noises of any kind should be audible until the catwhisker is placed upon a sensitive point on the crystal. It will be found very simple to locate a good

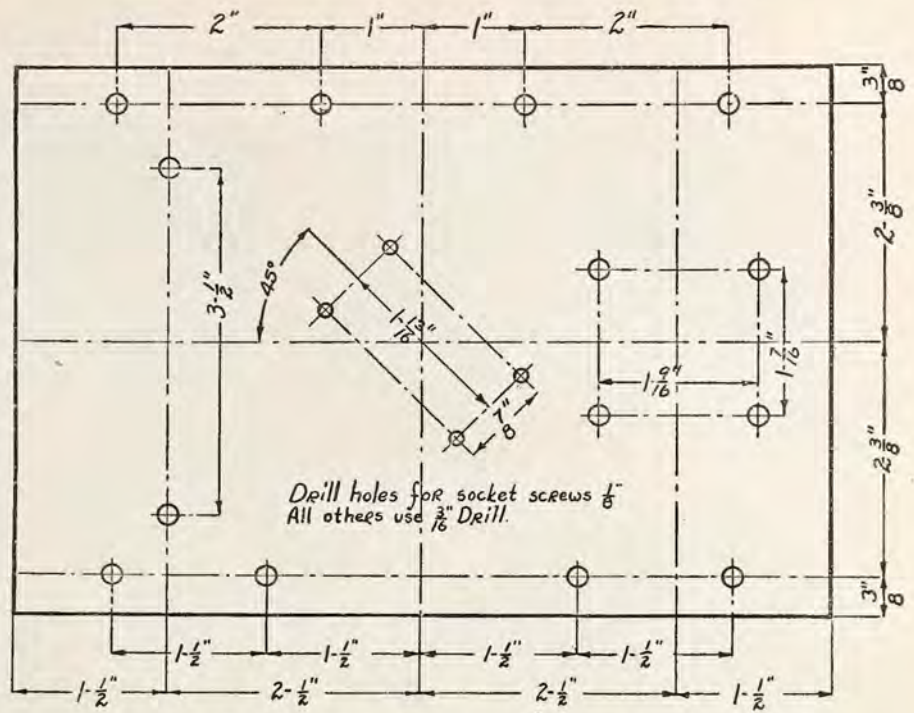

Figure 4. How to drill the holes on the tube and transformer shelf.

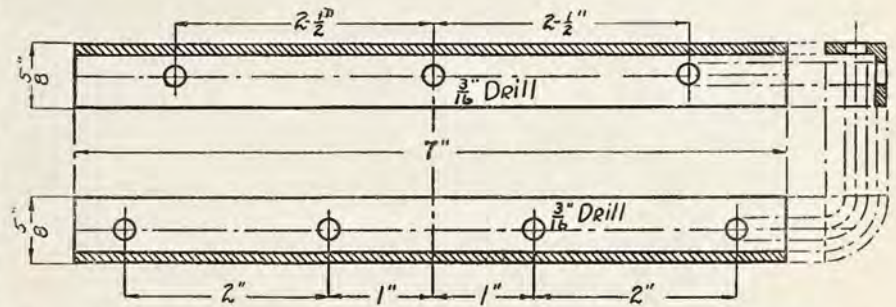

Figure 5. The bracket supporting the shelf is drilled in the manner shown here-with for the best mounting arrangement.

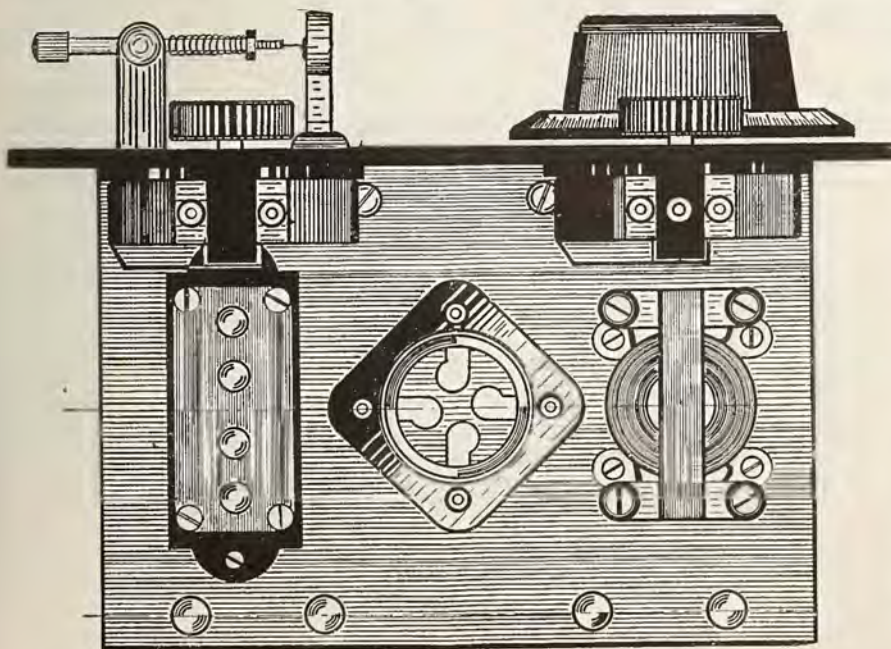

Figure 6. A top elevation of the Sure Fire Reflex.

spot, as the crystal is very easy to operate when strong R. F. voltages are applied to it. Any good crystal rectifier such as galena, radiocite, silicon or carborundum will be satisfactory. Their grade of sensitivity will be about in the order named.

When a broadcasting station is tuned in on the dial the potentiometer and rheostat are given further adjustments until the signal is at maximum intensity. It may be well to try for a better point on the crystal also as this will make a marked difference on the strength of the received music. Several bulbs should be tried out until a good one is found, as all 201A's will not reflex equally well. In the writer's experiments a 5-watt power tube gave surprising results on a 6-volt A battery and 90-volts plate which is far below the rated plate voltage for these tubes.

It is suggested that this set by a little alteration in design may be adapted to a portable form including batteries and all by use of the UV199 tubes. In such case the panel may be made a little smaller. The rheostat and potentiometer would

(Continued on page 26.)

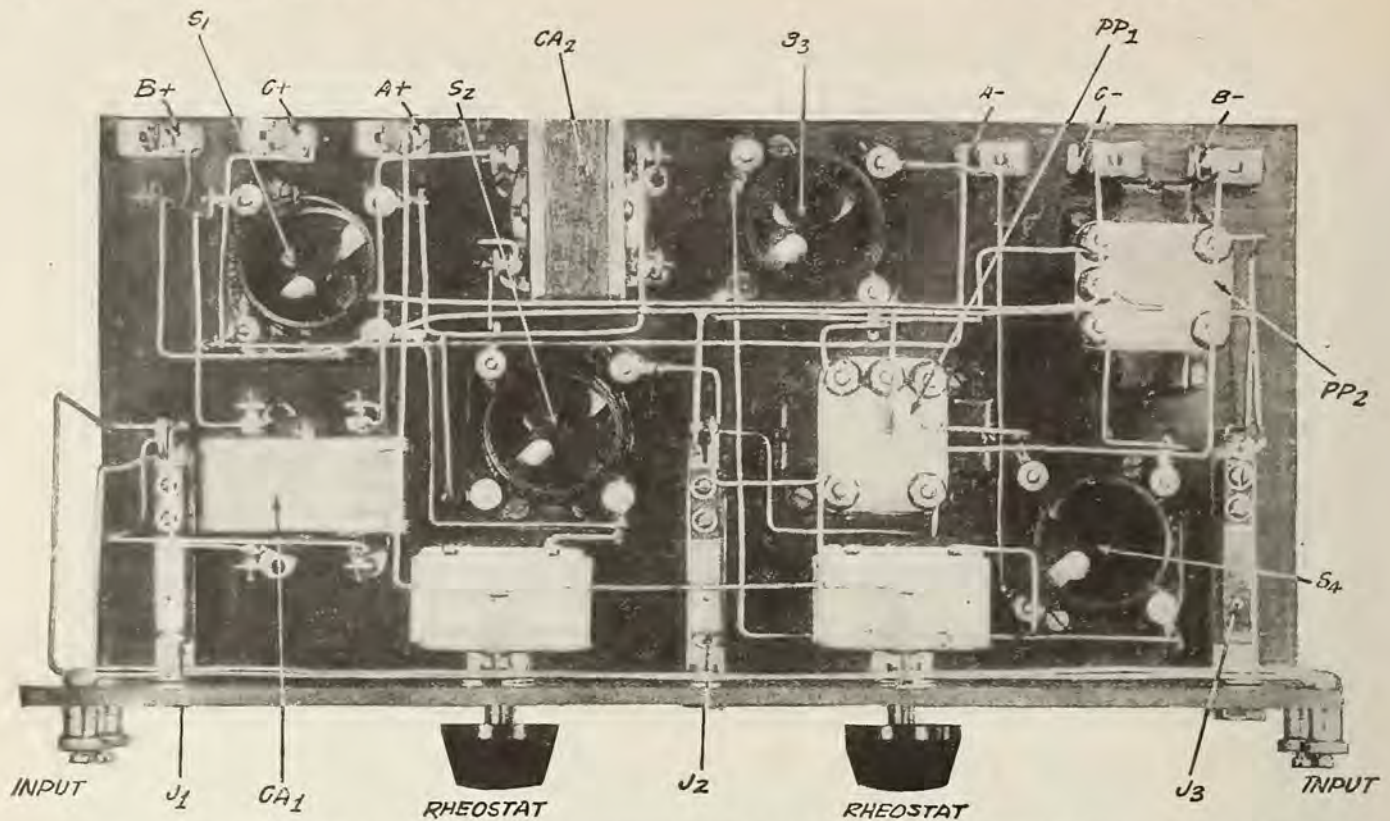

Figure 2. A top view showing the layout of apparatus and their respective mounting on the panel. Binding posts make connections with the wires going to the batteries through holes drilled in the back of the panel. The cabinet should be one with a hinged top.

## A Universal Amplifier

(Continued from page 10.)

- 2 rheostats, 6:10 ohms.
- 1 5-to-1 amplifying transformer.
- 1 3-to-1 amplifying transformer.
- 1 pair push-pull transformers.
- 4 tube sockets.
- 2 four-spring jacks.
- 1 2-spring jack.
- 6 Fahnestock binding posts.
- 4 panel mounting binding posts.
- 7 small wood screws.
- 20 feet tinned copper busbar.
- 4 UV 201-A tubes.
- 1 nine-volt C battery.
- 2 forty-five-volt block batteries.

The panel should be drilled in accordance with Figure 5, which shows the back view of the unit. It is quite necessary to adhere to this method of drilling if the layout of apparatus shown in Figure 2 is to be used.

### Two Rheostats Used

The apparatus should be placed as shown in Figure 2. It will be noted that this affords short connections; it places all transformers with cores at right angles, thereby reducing chance of interstage coupling, and yet preserves the symmetry of the unit so that the tube sockets will come directly behind the peep holes drilled in the panel.

Only two rheostats are used, one controlling the cascade amplifiers, and the remaining one controlling the balanced amplifier. Rheostats should be from 6 to 10 ohms if UV 201-A tubes are used, and

they should provide sufficient resistance for the two tubes when used in parallel. If the type of rheostats shown are used, the connections should be made in accordance with instructions accompanying them. The jack, J1, connects to the plate circuit and B battery of the detector, and provides a means of using the detector alone if so desired.

When the plug is inserted in J2 and the first rheostat is turned on, the cascade amplifiers are in use. When the second rheostat is turned on and the phones plugged into J3, the balanced amplifier is automatically connected into the circuit and the entire component is used.

The writer is aware of the fact that there are many receivers built with both right and left hand outputs, and has therefore incorporated the idea of two input sets of binding posts on the front of the panel. This is a matter left to the judgment of the builder, who can decide which is the most efficient from the construction of his present set.

Figures 3 and 4 are the working sketch and wiring diagrams respectively. The wires are numbered to correspond to reduce the possibility of incorrect connections.

Figure 5 is another view of the unit, showing how the arrangement looks from a rear elevation.

### Getting Rid of Noise

In all cases the lettering refers to the following parts. CA1 is the first cascade transformer; CA2 the second; PP1 and PP2 are the push-pull transformers; S1, 2, 3, and 4, the tubes and sockets; J1, 2,

and 3, double and single circuit jacks respectively, binding posts being lettered in accordance with their respective values.

It is a wise plan if the set is found to be noisy to place a .00025 MF fixed mica condenser across the secondary (G and F posts) on the cascade transformers and across this condenser connect a grid leak of the pencil mark type. This invariably reduces noises and clears up reception.

The signals can be adjusted further by placing the low ratio transformer in the first cascade amplifier circuit, and by shunting a .001 MF fixed condenser across the input posts on the panel.

The RADIO AGE data sheets printed on pages 37 and 39 should be carefully filed away as described in the preceding issue.

In a comparatively short time these sheets will represent a world of valuable information and reference.

Don't fail to save them.

# Broadcaster Wins Copyright Suit

ONE of the most important court decisions in the history of radio was handed down in the United States District Court at Cincinnati, when Judge Smith Hickenlooper ruled that radio is not a public performance for profit and the broadcasting of copyrighted music does not constitute a violation of the copyright laws.

Accordingly Judge Hickenlooper dismissed a suit filed by Jerome H. Remick & Company, Inc., New York music publishers, against the Crosley Radio Corporation, in which the plaintiffs attempted to compel the Crosley Corporation to pay a special tax for permission to broadcast copyrighted music.

## Not For Profit

The rendition of a copyright musical composition is not a "public performance" within the meaning of the music copyright law, the judge explained, because in making the copyright statutes Congress intended that there must be an assemblage of persons congregated at the place of amusement for the purpose of hearing the music.

The Remick petition was dismissed on the grounds that the facts stated did not establish just cause for action.

The decision will have an important bearing on the radio industry and the development of broadcasting, as it literally makes the air free for radio. It gives broadcasters the right to play all music,

whether copyrighted or not, without their being compelled to pay a special tax to the American Society of Composers, Authors and Publishers, of which the Remick Company is a member.

The Crosley company's attorneys' sole contention was that the broadcasting of a song is not a public performance for profit.

## History of Campaign

The campaign against broadcasting stations was started by certain members of the American Society of Song Writers, Authors and Publishers, about two years ago. They began by notifying the studio directors that they could not play certain music unless they announced before each selection that it was being played by permission of the society.

There was no objection to this on the

part of the broadcasters, and the wishes of the society were complied with. Some time later the society notified all broadcasting stations that they must pay a special tax to the society before they could play copyrighted music. There were a number of station owners who agreed to the request of the society and paid this tax, but there were others, including the Crosley Radio Corporation, who contended the imposition of this tax was unconstitutional and refused to pay it. A large amount of music was being published by independent music houses, and distributed among the radio stations by the National Association of Broadcasters, and from this the radio stations selected their songs.

The task of eliminating all copyrighted music, however, was a fairly large one, and due to an error a copyrighted selection



Photo Topics, Inc.

## THE LINE FORMS ON THE RIGHT

When the New York Police Department placed a ban on loud speakers in front of stores, the Chamberlain Electric Company showed a bit of enterprise to gain the attention of passers-by. They hitched up a few sets of earphones to a set displayed in the window, and offered them to pedestrians who cared to listen in. The number of persons who stand in front of the window was limited, but the "fans" waited in line to get a few bits of a popular concert.

was played from W L W. This happened to be a song published by the Remick Company, and so that organization filed the suit.

The latest decision regarding broadcasting of copyrighted music will be appealed and probably will go to the United States Supreme Court, unless the National Association of Broadcasters succeeds in having the Copyright Act amended.

The Association of Broadcasters, however, has warned its members against using American Society music, on the basis of the decision, because broadcasters must remember that this is a decision merely by a single judge, and that judge himself is of the view that his decision is contrary to that of another Federal judge. If the highest court reverses this decision, then various penalties for infringement would be enforced. Broadcasters are therefore advised to avoid using any music except that which is released and approved by the National Association of Broadcasters.

### Amendment In Senate

Whether copyright laws will apply to compositions broadcast in the ether, requiring payments of royalties to the authors, composers and publishers by the broadcasting stations, is now up to the Senate Patent Committee. Considering the mass of testimony, pro and con, given in two days of hearing on the amendment to the Copyright Laws proposed by Senator C. C. Dill, which would eliminate broadcasters from paying fees to copyright holders, it may be some time before the committee can digest the matter and make a report.

"Like free speech, religion and the freedom of the press, he wants radio unhandicapped and uncontrolled," Senator Dill said. "If moving pictures and automobiles took their people out of their homes, radio has a tendency to bring them back. The listener-in should not be taxed, and he is confident that through radio a universal language will develop which will better unite people of all nations, and may prevent future wars."

Opposition to his measure, The Dill Bill, S2600, is strong, however, and Senator Dill's plans may be defeated in committee or later on the floor.

Leading musicians, authors, composers and publishers appeared before the Senate Committee, in opposition to the Dill Bill. In general they were members of the American Society of Composers, Authors and Publishers, but some independents also testified.

Those present included Gene Buck, president of the society; Victor Herbert, vice-president; E. C. Mills, chairman of the administrative committee; Ellis Barker Butler, president of the Authors' League; John Philip Sousa, Augustus Thomas, and Nathan Burkam, attorney for the Composers' Society.

Mr. Buck said he was appearing in opposition to the Dill Bill "for the life of song writing," and flatly denied that the Publishers' Association was a monopoly or trust of any kind. Questioned, Mr. Buck answered that the association, in asking broadcasters to pay for using songs, does not differentiate between a station operated by a radio manufacturer or one operated by a newspaper. He contended that when people hear a song over the radio they do not care to buy it and said that the continual use of a song in the air made the people "sick of it."

### Herbert and Sousa Oppose

Victor Herbert and John Philip Sousa also opposed the bill, contending that the present copyright law should not be changed.

Charles H. Tuttle, of the National Association of Broadcasters, stated that radio was the greatest blessing that science ever had given to man. He accused the composers of "passing the buck" to the listener-in and claimed that the composers wanted the broadcasters to join with them in an agreement to charge the public, in which case it would be one of the greatest monopolies ever realized. He denied that radio was emptying the moving picture houses. The Composers' Association was said to be trying to tax the radio broadcasters and not the individual

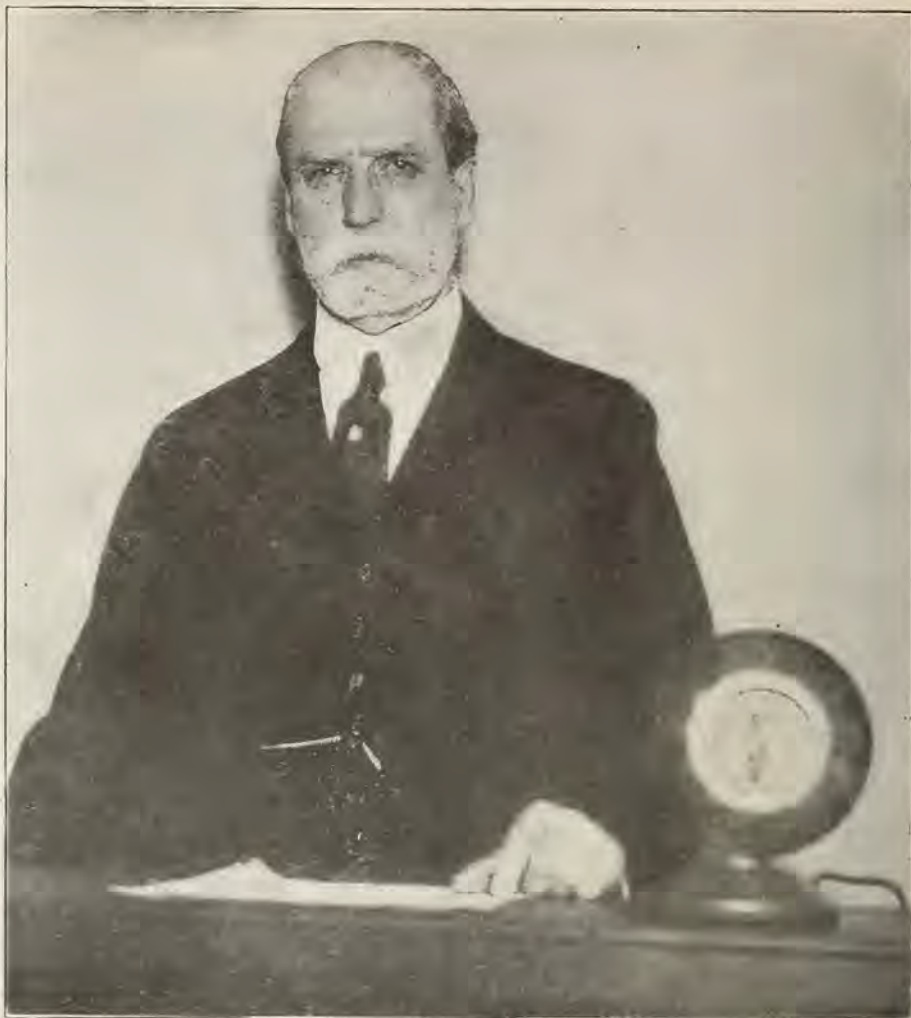

Kadel & Herbert Photo.

### SECRETARY HUGHES OPENS CONVENTION

Charles Evans Hughes, secretary of state, made an impressive keynote speech before the Republican State Convention in New York recently; doubly impressive because his message was broadcast to eager partisans who could not attend the convention. Here he is before the microphone, addressing the convention and his ethereal audience.

songs which they send out. He believes that the music publisher is opposing the bill and not the writers and authors.

### Drake Takes Over WDAP

Arrangements were completed last week whereby The Drake Hotel, Chicago, is to assume permanent control of Station WDAP, formerly owned by The Chicago Board of Trade. While the broadcasting of market reports is expected to be continued, the new owners have announced they will reorganize the operation of the station and possibly apply for a new wave length. The call letters also may be changed. Jack Nelson, who has been director of the station for several months, will continue in that capacity. An extensive series of interesting programs is being arranged for June, it was said.

### Radio Helps Solve Mirage

When approaching Sydney, Nova Scotia, recently, Captain Bauge of the Hospital Ship St. Joan of Arc, was confronted by a mirage which distorted the

shore lines so they could not be recognized. Calling his radio compass into service, he took radio bearings from North Sydney, Magdalen Island, and Canso, with the result that he succeeded in locating his position.

Endeavoring to find the proper point at which to land in a fog, Captain Bauge and a native fisherman who was on board were greatly confused by a mirage which changed the appearance of the coast. They knew they were not in front of Scarati, for a steep cliff could be seen behind the lighthouse, obviously not the gentle sloping hill of the Nova Scotia shore, five miles distant from the lighthouse.

Standing by temporarily until the sun came out, the skipper took an altitude, which plotted with his radio bearings, intersected in a triangle of error of less than three miles on a side. He was east-northeast of Scarati. Soon the lighthouse appeared in its natural place. The radio compass proved correct, he states, despite the "evidence" of their eyes.

# The Why of the Heterodyne

By JOHN B. RATHBUN

UP TO the present time, nearly every article published on the subject of the super-heterodyne has started out in the same way, and after reading our first article on the subject we can generally omit the first page and a half of each succeeding article with perfect safety. Possibly this is perfectly correct for articles dealing with so novel a principle, but at times it is rather a bore to read the constant reiteration on the theory of beat reception or how two superimposed waves of different frequencies lead to a resultant wave of a different frequency or wave length. In view of all this repetition on the development of the long wave or beat note, it seems exceedingly strange that all of the writers gracefully side step the true purpose of all this elaborate preparation and entirely fail in telling us why amplification at radio frequencies is more efficient on long wave lengths than at broadcasting frequencies.

In this little sketch I am going to depart somewhat from the conventional and attempt to short description of what takes place in the intermediate stages after the broadcasting waves have passed through the frequency changing stage of the circuit. We will therefore assume that the long wave resultant has already been created in the oscillator-tuner stage by some means or other, and that the low frequency wave has just entered the first stage of the radio frequency amplification system, where it is to be amplified before entering the second detector tube for reduction to audio frequency. Whether this long wave has been created by the superimposed oscillations of a tube or by those of a motor-generator is no concern of ours at the present.

## Amplification Wavelength Differs

To begin with we must understand that the super-heterodyne is essentially a radio frequency amplification circuit, and in many ways comparable with the standard R. F. circuits or the well-known neutrodyne. The incoming waves are first amplified before the final detection and reduction to audible waves which affect the diaphragms of the phones or loud speaker. The outstanding difference lies in the fact that the radio frequency waves in the heterodyne are amplified at a constant frequency under all conditions and not at any old wave length that the set may happen to be tuned in on. Both the standard radio frequency sets and the neutrodyne carry on amplification at the broadcasting wave lengths of the various stations, but the super-heterodyne amplifies at one constant wave length regardless of the station wave length.

## Advantages

It has been intimated in the 101 articles on the subject already printed that amplification at a constant long wave length greatly increases the effectiveness of the radio frequency amplifying stages. It permits of a degree of amplification not approached by the standard radio frequency circuits or by even the neutrodyne. The whole circuit, transformers, tubes and all, can be adjusted to their most advantageous frequency and then afterwards operated indefinitely at this optimum wave length. By this means we can more nearly approach the full output capacity of the tubes than by any other method yet proposed, and as we all know, the capacity of the tubes is the limiting factor in the

amplification of the waves. With circuits amplifying at varying broadcasting frequencies, it is not likely that we much exceed 60 per cent of the full amplification capacity of the tubes because of certain reactions that take place in both the tubes and the transformers.

As with all radio frequency circuits we have the regeneration or feed-back to contend with that is due to the capacitance or condenser effect between the grid and plate of the tube. The grid and the plate (in effect) form the two plates of an electrical condenser and through the capacitance of this small condenser, energy is fed back into the grid circuit from the plate circuit, thus introducing oscillations and other reactions which interfere seriously with amplification of the radio frequency circuit. An interchange of electrical charges also takes place in the reverse direction, from the grid to plate, so that a certain percentage of the grid charges are dissipated to the plate and hence the control of the grid over the electron stream is reduced. The net result of the grid-plate capacity is reduced amplification and range.

In the neutrodyne circuit, the capacitance or condenser effect between the grid and plate of the tube is "neutralized" by the introduction of small condensers known as "neutrodons" so that there is little feed-back or regeneration between the radio stages. The reactance of the neutrodons opposes the reactance of the grid-plate condenser, and hence is a decided step in advance of the standard radio frequency circuit. However, perfect neutralizing adjustment is seldom attained under practical working conditions, and many of the evils attending amplification

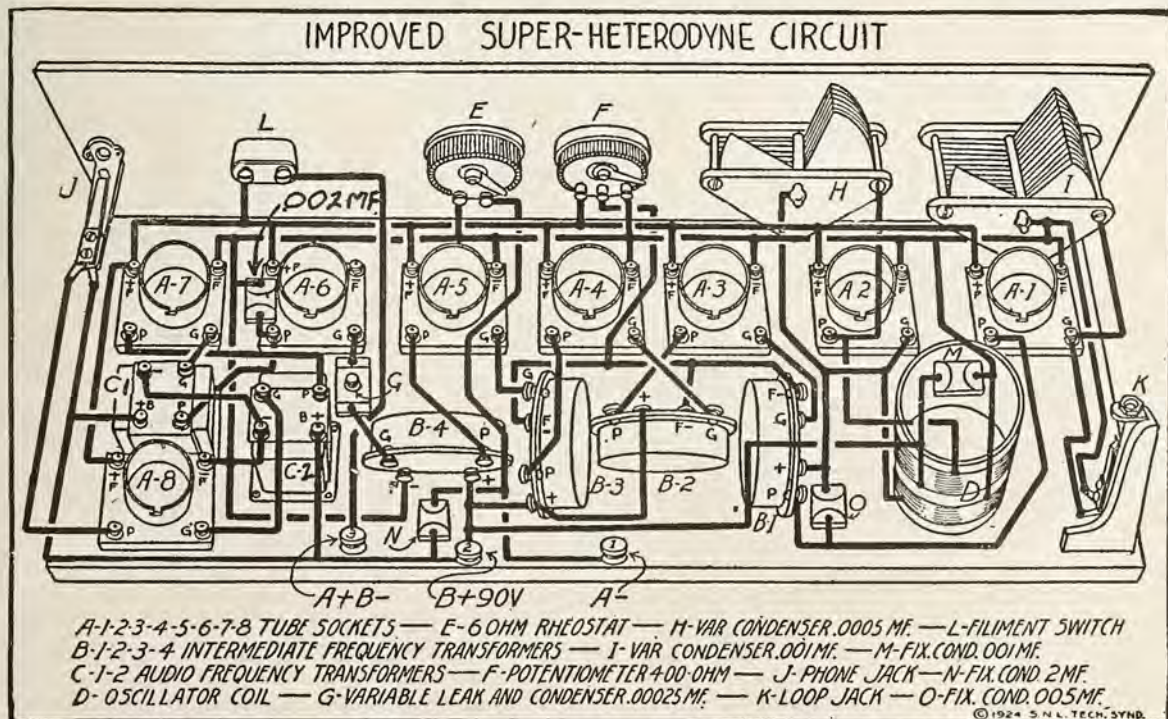

at high broadcasting frequencies still persist. For the complete elimination of the grid-plate condenser effect we must take up still another method of reducing the reaction, and this is to reduce the capacitance by a reduction in the frequency of the input current.

With any condenser the capacity varies with the area of the two metal plates, the distance between them, the nature of the insulation between the plates, and the frequency of the alternating or oscillating current supplied to the condenser. It is, of course, impossible to change the capacity of the tube grid-plate condenser by varying the area or spacing of these elements since they are sealed within the tube, and for the same reason it is im-

Danger from plate-grid feed back and regeneration ceases at about 1,500 meters wave length with ordinary commercial tubes having the usual internal capacities. At 2,000 meters there is very little chance for free oscillation to develop and there is a much less tendency toward picking up interference than at the higher wave lengths. The best wave length for the radio stages from a practical standpoint is still a matter of much discussion, but it would seem that there is a decided limit beyond which it is not practical to go. There are circuits which operate very satisfactorily at from 1,750 to 3,000 meters wave length and as a rule these circuits are not so noisy as those operating on 5,000 to 10,000 meters. An added ad-

dynamer depends more on the fact that the transformers are tuned to meet each separate incoming signal than upon the principle of neutralization itself. This, however, requires several variable condensers and as many controls as there are stages of amplification which adds to the difficulty of tuning.

With the heterodyne we gain all of the advantages of the neutrodyne in having closely tuned transformers, and at the same time avoid the many controls since our transformers are tuned once and for all time by means of a fixed condenser set for the constant wave length. In the heterodyne we have only two controls, the wave length (tuning) condenser, and the oscillator condenser, while in other

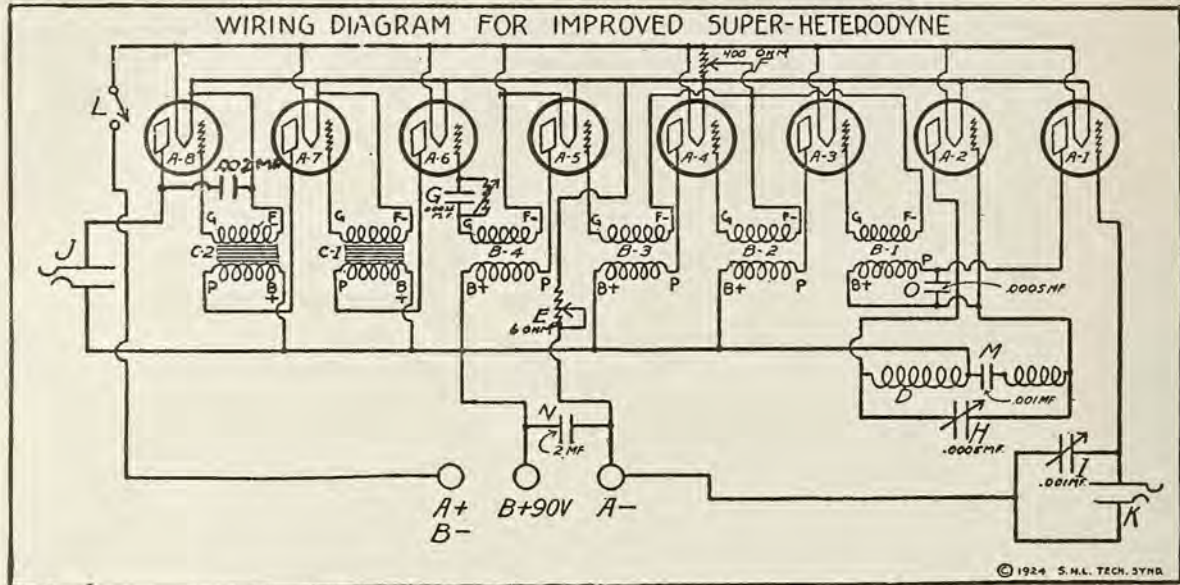

possible to make changes in the nature of the matter between the elements. However, it is possible to reduce the capacity of the grid and plate by reducing the frequency or wave length of the current in the plate and grid, and this is exactly what is done in the super-heterodyne circuit.

At wave lengths of 3,000 to 10,000 meters the capacity of the grid-plate condenser is very much lower than at the ordinary broadcasting range of 300 to 600 meters, and hence there is much less tendency to feed back or oscillate on the long wave lengths. Instead of receiving the high frequency station currents directly in the amplifying tubes, the frequency is first reduced by the oscillator circuit to that frequency which gives the least tube condenser effect. Theoretically this minimum capacity would be had at wave lengths just above audible frequency, but practically it is not desirable to use such long waves because of other effects which develop in the circuit. A wave length of 10,000 meters is probably the longest wave in common use, and this is far above audible frequency. With wave lengths above 5,000 meters the circuit is likely to suffer from interference due to long wave length stations, and it is much more likely to pick up noises caused by atmospheric disturbances or waves emanating from the electrical circuits of industrial plants and electric railway systems.

vantage attending the use of the shorter wave lengths lies in the fact that the radio frequency transformers are simpler.

With wave lengths approximating 2,000 meters we can construct very cheap, simple transformers of the air core neutrodyne type which need only have from 250 to 350 turns of wire in the secondary coil. On 10,000 meters we may require a thousand or two thousand turns on the secondary, thus both increasing the size and the cost of construction. Transformers of the 5,000 to 10,000 meter class are not easily built at home.

#### Heterodyne Transformers

A second point in the consideration of the superior efficiency of the heterodyne radio frequency circuit is the great amplification peak possible with the transformers when they are operated at a constant frequency or wave length. As they work at a single constant wave length they can be carefully tuned to this point when they are built, thus obtaining a maximum ratio without the necessity of repeated retunings every time that the wave of the station is changed. The ordinary type of short wave untuned transformers designed to operate on a wide range between 200 and 600 meters give a very low amplification except at one or two points in this range. It is very possible that the great superiority of the average home-built neutro-

dyne radio frequency systems using tuned transformers we have as many condenser controls as there are radio frequency stages (plus one).

Operating an ordinary radio frequency set with untuned condensers is much like trying to operate an ordinary receiving set without tuning controls. At all wave lengths, except one, the reception will be very weak and the selectivity is greatly reduced. You can hardly imagine a receiving set built without a coupler or without a tuning condenser, but this is practically equivalent to what takes place when untuned radio frequency transformers are used. If you do not believe this, just connect an ordinary short wave untuned radio transformer in place of your vario-coupler and see what happens.

There is one advantage in the heterodyne circuit which seems to have escaped the notice of the transformer manufacturer, and that is the possibility of using high transformer ratios. With the plate-grid capacity effect reduced to a minimum it would seem that higher ratios would be possible than are ordinarily used without danger of the tubes breaking down into free oscillations. In the majority of cases the present transformer ratios are in the nature of two to one, with four to one as a maximum. When ratios of five to one, and even eleven to one, are used in

(Continued on page 56.)

# Adding Radio and Audio to Baby Heterodyne

By JOHN B. RATHBUN

**I**N RESPONSE to the many inquiries for the addition of radio and audio frequency stages to the baby heterodyne, the following circuit has been devised which gives two stages of radio frequency amplification, detector, and two stages of audio frequency amplification. This five tube set requires the usual precautions against setting up free oscillations in the tubes and feed-backs that must be taken with all radio frequency sets, but when everything is adjusted it will pull in distance with probably twice the range of the detector alone. The audio stages of course permit of loud speaker operation upon fairly distant stations.

The basis of this circuit is the single tube heterodyne which occupies the position in the circuit marked "detector," and this will be quickly recognized by those who have read or used the article in the February issue of Radio Age. The two coils marked (M-N) correspond to the coils (M-N) in the February issue and are almost historic by this time. It should be particularly noted that the detector circuit is supplied with plate current by a separate "B" battery (-B2, \*B2) which is necessary for proper operation. The first "B" battery supplies both the radio and audio frequency circuits in the usual manner.

The first change necessary is the removal of the old fixed coupler from the simple detector circuit. This is removed and used as the first tuning inductance at (FC) at the extreme left where the primary and secondary coils are marked (P) and (S) respectively. In the detector circuit, the tuning unit is replaced by the ordinary neutrodyne transformer (RFT-2) or by another radio frequency transformer as will be described later.

As shown in the diagram, two air core transformers of the neutrodyne type are shown at (RFT-1) and (RFT-2), the secondaries (K) of these transformers being tuned by the 17 plate (0.00035 mf) condensers marked (C2) and (C3). The secondary coils (K) are wound with 66 turns of No. 24 D.C.C. wire, while the primary coils (J) have only eight turns of the same wire, this giving a transformer ratio of over eight to one. These can be made at home, winding the coils on 3-inch paper or bakelite tubes, but it is easier and cheaper to buy standard neutrodyne coils for this purpose. If the coils are wound at home, care must be taken to wind the small coil (J) at one end of the tube so that it is separated by a short distance from the coil (K).

The use of the above transformers, while giving the maximum results, gives us a great many controls to handle, or in fact we have four tuning controls which are quite critical. While this gives almost 100 percent selectivity, yet it is tedious and decidedly bothersome for the beginner. The use of ordinary untuned radio frequency transformers at these points, such as the Erla, Acme, Rasla, and others, does away with the necessity of the condensers (C2) and (C3), and thus reduces the controls to two units. The volume and distance will suffer accordingly but this sacrifice is sometimes advisable in view of the difficulties just mentioned.

The two radio frequency tubes (1) and (2) are controlled by a single rheostat (R1), and the grid potential is regulated by the 200 ohm potentiometer (PO). The latter is necessary to prevent oscillations in these tubes but is not critical. The detector tube (3) is contained in the circuit already familiar to our readers and is controlled by the rheostat (R2). This

should preferably be a vernier rheostat. As before, (L) is a 50 turn honeycomb coil and (C4) is the condenser controlling regeneration and frequency.

This brings us to the audio frequency tubes (4) and (5) which are controlled by the single rheostat (R3). The iron core radio frequency transformers (AT-1) and (AT-2) can be any good make, preferably with a ratio of five to one, although other ratios can also be used. For maximum amplification (AT-1) can have a ten to one ratio, but for clear undistorted speech a five to one ratio is best. You will note that the four terminals of these transformers are marked (P), (G), (\*B) and (-F) as usually found on the posts of such devices.

For maximum amplification, reduced distortion, and minimum "B" battery current, a small biasing battery marked "C" is used with its negative pole connected to the (-F) posts of both audio transformers as shown. This is simply a small three cell flashlight battery giving a potential of about 4.5 volts, and is connected directly into the circuit as there is no flow of current when the set is idle. The output of the set is at the extreme right, and no jacks are provided since in a circuit of this sort it is not advisable to introduce any more capacity than is absolutely necessary.

For the radio and audio stages, as well as for the detector circuit itself, about 67 volts of "B" battery will give the best results. For economy, we can use 45 volts at (B2), but a higher voltage will give better results. It goes without saying that all of the tubes, detector tube (3) included, must be hard amplifying tubes, such as the UV-201A, C-301A and UV-199 or C-299. A soft tube like the UV-200 will not work at the high plate voltages

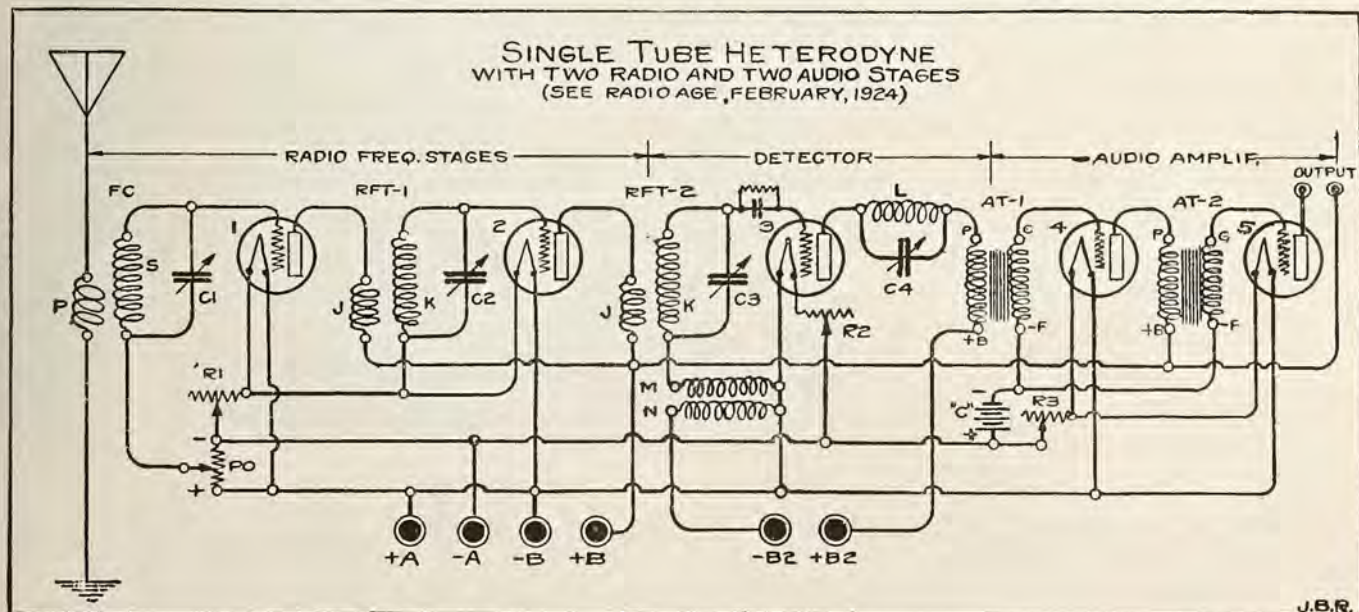

given. Please, please, please do not use either the WD-11 or WD-12 tubes in a circuit like this, and then write in and ask why you are not getting results. If I had my way about it I would pass a law against the use of WD-11's in everything except Ultra-Audions and similar single circuit sets.

Now returning to the front end of the cingus at the left, we see our old friend the fixed coupler (FC), alias the "Wizard" coil, alias several other names. This contains 28 turns in the primary (P) and 60 turns in the secondary (S), all wound on a three inch tube with No. 24 D.C.C. or No. 26 D.C.C. wire. Full details were given for the construction of this coil. Yes, you can also use a four inch tube or a five inch tube, providing that you reduce the number of turns in proportion. The tuner coil (FC) has its secondary coil tuned by the same old 23 plate (0.0005) condenser that we used in the old detector circuit, and is indicated by (C1).

This will require a 7x26-inch or a 7x28-inch panel, the latter preferred if neutrodyne type coils are used for radio frequency transformers. With these transformers, do not have the coils closer than 5.5-inch centers, and turn them at an angle of 45 degrees so that the bores of the tubes will not be in line. If each transformer (RFT-1, RFT-2) is turned at an angle of 45 degrees with the horizontal and vertical, then there will be no "feedback" nor regeneration between the radio frequency stages, but if all the transformers are in line, then you will get no results whatever for the energy will be short circuited between the transformers and the radio tubes will not amplify.

### Latest Radio Frequency Transmissions

The Bureau of Standards is transmitting special signals of standard frequency about twice a month. The next schedule is announced below. The signals can be heard and utilized in general east of the Mississippi River.

These special signals of standard frequency are of use to testing laboratories, transmitting stations, operators, and others in standardizing wave meters and adjusting transmitting and receiving apparatus. The transmissions on June 5 will be of special interest to ship operators, those on July 7 to amateurs, and those on June 20 to broadcasting station operators. The accuracy of these signals is better than three-tenths of one per cent. Information on how to use them was given in the February, 1923, issue of the Radio Service Bulletin. More detailed information is given in Bureau of Standards Letter Circular No. 92, which may be obtained, on application from the Bureau of Standards, Washington, D. C.

All transmissions are by unmodulated continuous-wave telegraphy. A complete frequency transmission includes a "general call," a "standard frequency signal," and "announcements." The "general call" is given at the beginning of the eight-minute period and continues for about two minutes. This includes a statement of the frequency. The "standard frequency sig-

nal" is a series of very long dashes with the call letters WWV intervening.

This signal continues for about four minutes. The "announcements" are on the same frequency as the "standard frequency signal" just transmitted, and contain a statement of the measured frequency. An announcement of the next frequency to be transmitted is then given. There is then a four-minute interval while the transmitting set is adjusted for the next frequency.

The schedule of standard frequency sig-

nals from the Bureau of Standards is as follows:

Eastern Standard Time	June 5	June 20	July 7
11:00 to 11:08 P. M. ....	300 (1000)	550 (545)	1363 (220)
11:12 to 11:20 P. M. ....	315 (952)	650 (461)	1330 (210)
11:24 to 11:32 P. M. ....	345 (869)	750 (400)	1500 (200)
11:36 to 11:44 P. M. ....	375 (800)	833 (360)	1600 (187)
11:48 to 11:56 P. M. ....	425 (705)	940 (316)	1700 (176)
12:00 to 12:08 A. M. ....	500 (600)	1050 (285)	1800 (167)
12:12 to 12:20 A. M. ....	600 (500)	1150 (261)	1900 (158)
12:24 to 12:32 A. M. ....	657 (750)	1250 (249)	2000 (150)



Kadel & Herbert Photo.

### AND THE AIR WAS FILLED WITH ELOQUENCE

Leave that to William Jennings Bryan. For the first time the famous publicist delivered an address recently on "The Election of 1924." Here he is shown before the microphone of WJZ at the Hotel Commodore, New York City. By means of radio millions were able to hear Mr. Bryan's fiery address for the first time in their lives.



# What the Broadcasters are Doing

## Schenectady Announcers

Radio, the newest industry and science, now claims the labor of 250,000 people and the leisure and rest of countless more. In the broadcasting branch of the science a new vocation has developed, that of the radio announcer.

To be a successful announcer something more than a pleasing voice and clear enunciation are required. The ideal announcer is a musician with a knowledge of composers and their work; he should be a linguist familiar with French, Italian and German; he should be able in an emergency to make an announcement in English without confusion and free from grammatical errors. He must be tactful in receiving artists and instructing them in proper position before the microphone.

Singers and speakers accustomed to public appearance very often develop microphone fright, not because the studio surroundings are overpowering but because they miss the stimulating presence of an audience; it is difficult to visualize the vast radio audience, headphones on head or grouped about loud speakers.

The announcer's duties are not limited to his appearance before the microphone. At WGY, the popular station of the General Electric Company at Schenectady, rehearsals are conducted by one of the group of six announcers at WGY. By means of the try-out poor singers are saved the embarrassment of failure before the microphone. The rehearsal also serves to demonstrate that certain voices have not the quality for radio transmission. Sometimes the finished and successful singer is found to have a voice unsuited for radio transmission and on the other hand a singer whose voice is too weak for public hall or theatre, sometimes possesses quality and tone which win instantaneous popularity with the radio audience.

Four of the six announcers at WGY are vocal soloists and may, in the event of an emergency, such as the failure of scheduled artists to arrive, step before the microphone and give a creditable performance. Kolin Hager, the chief announcer, has been associated with WGY since the station opened. He is a trained musician, linguist and public speaker. When a boy he was soprano soloist in an Albany Cathedral and is now baritone soloist in a Schenectady church. Carl Jester is a tenor with a thorough musical education, and for the past year he has directed the WGY Light Opera Company in its various appearances.

Asa O. Coggeshall, also a tenor, a third



Kadel & Herbert Photo

## THE THREE MUSKETEERS OF WLS

These jolly chaps keep their ethereal customers smiling from WLS, the Sears-Roebuck Agricultural Foundation Station at Chicago. From left to right they are George D. Hay, the "solemn owl of Memphis," and chief announcer of WLS; Ford Rush, director of music and Robert Northrup, assistant announcer and entertainer. Mr. Hay is shown with the locomotive whistle that made him famous among the fans down in Dixie.

announcer, is director of a boy choir in an Amsterdam, N. Y., church. William Fay, the last to join the announcer force at WGY, is a baritone, and his voice has brought him many fan letters.

The other announcers at Schenectady station are Robert Weidaw, who gives much of his time to the executive work of the studio, and Edward H. Smith, who is director and leading man of the players, and assists in planning feature programs such as Uncle Josh's golden wedding, and minstrel shows. An entire evening's program may be put on by the announcers without the aid of outside talent.

**WANTED:** Contributions to the Pick-ups Page. Lists of stations heard; see February 1924 issue of RADIO AGE for particulars. Short stories under 250 words in length; jokes and anecdotes; brief sketches of humorous incidents in radio building; summaries of experiments with receiving sets; listening experiences; photographs, wiring diagrams; also any other interesting items. Address: RADIO AGE, Box PP, 500 N. Dearborn St., Chicago, Ill.



Kadel &amp; Herbert Photo.

### A NEW ERA IN NEWSPAPER PUBLISHING

A group of astonished newspaper editors, electrical and radio engineers at the American Newspaper Publishers' Convention in New York watched a radio typewriter being operated by a person who was sitting in an experimental laboratory more than two miles away. The "copy" was received and typed at a rate of sixty-five words a minute and with an accuracy of 99½ per cent. The machine operates on a short wave tuner ranging from 60 to 150 meters, with detector and amplifier. The new device is expected to revolutionize transmission of newspaper messages.

#### First to Hear McMillan Gets \$100

The first amateur who succeeds in picking up the Donald B. McMillan station, WNP, on the Schooner Bowdoin, now frozen in within eleven degrees of the North Pole, will be awarded \$100.00 in gold by U. J. Herrman, managing director of the Radio Manufacturers' Show Association, which will hold radio shows in New York and Chicago this Autumn.

To the next amateur who reports a confirmed reception of the McMillan expedition's transmission, E. F. McDonald Jr., president of the Zenith Radio Corporation, will award a Zenith receiving set—an exact duplicate of the one in use on the Bowdoin.

The offers are made to stimulate watchfulness on the part of amateurs who can receive code messages from WNP. Nothing has been heard from the McMillan party since May 10. Amateurs who pick up messages sent from WNP are asked to telegraph to Mr. Herrman, at 127 North Dearborn Street, Chicago, or to Mr. McDonald at 332 South Michigan Avenue, Chicago, care the Zenith Radio Corporation.

To the sender of the first telegram containing a message from the McMillan party, which it is possible to confirm, \$100.00 in gold will be awarded.

#### Phonograph Broadcast Succeeds

Successful broadcasting and re-recording of phonograph records have been accomplished by experimenters at WGN, the Chicago Tribune-Zenith station at Chicago.

When WGN went on the air with its inaugural program Saturday, March 29, Frank Hoyt, inventor of a new method of recording broadcast reception, tuned in at his laboratories in New York City and recorded his reception of the program on aluminum disks.

He succeeded in recording virtually all of the program, which continued from 6 p. m. Saturday to 6 a. m. Sunday. Some of the records were brought to Chicago and under Mr. Hoyt's supervision they were broadcast as a part of WGN's regular program for Donald B. McMillan, whose ship is frozen in eleven degrees from the North Pole.

This broadcast of a previous recording was received in Chicago and New York, and the broadcasts were received with sufficient clarity and volume to be recorded again. This is said to be the first time such an experiment has successfully been carried out on a large scale, according to Ben Garetson, director of WGN.

#### WTAM "Takes the Cake"

George A. Rudd, a Cleveland confectionery manufacturer, enjoyed the special Easter concert from WTAM so well that he bought a gaily decorated cake and sent it to the radio artists as an appreciation. The cake measured eighteen inches in diameter and was six inches high. The decorations were in all colors of the rainbow. The pastry donation was heartily received by the radio artists, and Art Herske, the announcer, became so enthused over it that he forgot to sign off.

#### Girl Wins Radio Drama Prize

"A Million Casks of Pronto," a comedy drama of business life, won first prize in the radio drama competition conducted by WGY, the General Electric station at Schenectady. Miss Agnes Miller, of 150 East Seventy-second Street, New York, wrote the play, which will bring her a cash prize of \$500.00. The object of the competition was to develop a type of play especially adapted to radio presentation, and which tells its story through an appeal to the ear and imagination instead of to the eye. The winning play will be presented by the WGY Players soon.

# RADIOTORIALS

**T**HE NEXT member of Congress who tries to put an obstacle in the way of radio's progress will know he has a fight ahead of him. The recent victory of radio's friends in the United States Senate and the defeat of the proposal to inflict a tax of 10 per cent on all radio products proves that.

For some reason a Senate committee had figured it would be a smart bit of legislation to place a burden on the infant industry. There were senators who insisted they saw nothing illogical in forcing a fee from the schoolboy who undertook to build a receiving set—after being taught how to build it in a public school. Let the taxpayers finance the technical education of a radio-loving boy in a public school and then let the government impose a tax on what the boy makes.

That is not an exaggerated statement of the attitude of the pro-tax senators. Abandon this tax plan and give radio a full and free chance to show that it is a necessity, rather than a luxury? No, S-I-R! The senators wanted \$10,000,000 and they were going to raise it in radio levies.

But they did not. Radio interests combined to make the voice of radio heard down in Washington. It was a giant voice when it spoke. Manufacturers of radio sets and equipment used the newspapers, the direct mail campaigns and the broadcasting stations to inform the radio public of what was going forward. The users and prospective users of radio equipment were assured that they would ultimately pay the tax.

The country was astonished when the word was passed on to the big cities and the cross-road hamlets. Tax radio? Put a brake on an art in which the United States had just fairly shown that this country led the world in development of that art? Burden a science that was just beginning to show its tremendous value in the dissemination of information and entertainment? Interfere with the development of a science that had become an indispensable aid to the mariner and to commerce and world communication? Put a brake on a device that was knitting the peoples of all sections into a closer relationship and bringing the university course and the musical college to humble homes of millions? Put a tax on time signals, weather reports, United States agricultural reports, news bulletins, market quotations? Tax a science that is and will be a vital part of the army and navy in peace and war?

Well, the plan was fortunate in enjoying a painless death. The radio public was asked to tell Congress what it thought. The result was a protest that left nothing to be desired in the way of volume. Letters and telegrams swept in upon Washington. Politicians suddenly found themselves blinking into a calcium light. They discovered that this is a radio republic. The tax amendment came up in a session of the Senate and was voted down and out. It was beaten at a moment when the fans thought they were making only the preliminary moves to defeat it.

We would suggest that the next senator who wants to ease the burden on some private interest by tightening up on radio should go about it only after taking an aeroplane voyage over our little old country and counting the radio aerials on American roofs.

**A**N AGITATOR has appeared in the East who contends that the government should force broadcasting stations to give both sides of every political question an equal opportunity to use their microphones for the purpose of haranguing the public. With equal justice the government could force the newspapers to publish two editorial pages—one Republican and the other Democratic.

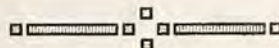

**S**ECRETARY HOOVER, of the Department of Commerce, is to call another national conference for the discussion of radio problems. He says the most serious menace to the proper enjoyment of radio broadcasting at this time is interference. Wave lengths of stations in the same community are within too narrow a band. More power to the Hoover elbow!

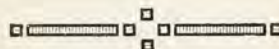

**W**HEN the S.S. "Columbus," a new ocean greyhound, arrived in New York recently, there was considerable interest in two lifeboats carried by the liner. These had been equipped with both transmitting and receiving apparatus. Once launched they readily could be transformed into sending or receiving stations. The vast possibilities of this development of radio are apparent at a glance. Engineers have devised methods of using radio to locate without loss of time miners who may be imprisoned by explosions or other accidents under ground. One railroad has its own broadcasting station with a system of minor transmitting and receiving stations. Chicago has a broadcasting station specially devoted to the interests of the farmer. Radio gives ships their bearings on storm-swept coasts. Radio has taken the place of the time regulator in the watchmaker's shop window; America is setting its clock by the signal from the broadcasting station. Radio is finding lost persons and lost property. Radio is helping to run down fugitive criminals. Radio is the liveliest thing in the United States. It is the only buoyantly alive industry in the country at this time. And yet the things that radio has accomplished and is accomplishing are only a beginning. The new season is to see radio step forth as a real giant, sure of its strength at last.

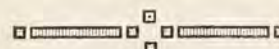

**A** GOVERNMENT radio expert predicts that before 1924 is over the ether will be entirely free of all interference. If we ever reach such a stage of radio bliss, tuning in on your favorite station will be just like turning on a phonograph. Please, Mr. Expert, leave us a little interference just for fun.

# Radio Does Not Electrocute

WASHINGTON, D. C.—Radio, unfortunately and unjustly, frequently gets a "black eye" through improper headlines and sometimes badly written stories in the daily press. The headline, "Electrocuted by Radio," which recently appeared in a local paper, was not only misleading, but wrong according to the brief story itself. In the first place, radio itself cannot electrocute anyone, except in case of transmitting stations where high-power supply is used. At the radio receiving end, radio is not dangerous.

It is even doubtful if the high-frequency power put into transmitting antenna at big commercial stations could kill, although it is admittedly dangerous to touch bare wire, the motor-generator, bus-bars, or the transmitting circuits, as a shock or burn might result. Only at high-powered, low frequency stations could serious results occur. Receiving sets are not dangerous, according to all well-informed experts, unless of course they are charged by outside electric power.

Referring again to the headline and the story of the unfortunate lad, who, it developed, let his antenna come into contact with an electric wire charged with 2,300 volts, it is readily seen that he was not electrocuted by radio but by an electric power line. It would have been the same had he been stringing a wire clothes-line, although his death would not have been charged to a clothes-line. An autoist who stalls his machine on a railway track and is killed by an express train is not said to have been killed by an automobile.

## Antennas Necessary

Some sort of an aerial is necessary to every receiving set, and it is well known that an outside aerial is better than an inside one or a loop, except in specially constructed high power tube receivers.

According to Dr. J. H. Dellenger, chief of the Radio Laboratory of the Bureau of Standards, a fairly long and high antenna is the cheapest way to get loud signals with the simplest receiving sets. "To get the best results, an outdoor antenna, used for great distances or for crystal sets, one should use a single, continuous copper wire, 50 to 150 feet long, direct from the set to the highest point available at the far end, supported by good insulators, such as porcelain or glass, and kept well away from trees and buildings. "Keep the antenna away from possible accidental contact with electric wires," he admonishes.

## Are Antennas Dangerous?

Replying to the query: "Are antennas dangerous?" Doctor Dellenger said:

"The lightning hazard is practically nil. Only for outside antennas need lightning protection be considered at all, it is very simple. A small and cheap device called a lightning arrester should be connected between the antenna and the ground wire on receiving sets. An antenna is no more likely to bring lightning into a house or apartment than are overhead telephones or electric light wires. The principal hazard from antennas is from stringing outdoor antennas over or near electric light wires. A number of persons have met death by electrocution from this cause." A special committee on the National Electrical Safety Code is now drawing up reg-

ulations and precautions for the erection and use of aeriels, and will report soon.

Concerning antennas in general, Doctor Dellenger pointed out that there is nothing about them to justify the large amount of worry and uncertainty they seem to give many uninitiated fans. An antenna, he explained, is the "harness" that converts the radio wave motions into currents which operate the receiving set. Almost any sort will work for a broadcast receiving set, he said, adding that fans do not need to imitate the amateur transmitters and erect elaborate antennas of several wires.

## Single Wire Best

A general antenna for reception should be a single wire running from the set, direct if possible to a conveniently high point at the far end. It does not have to be horizontal, a slight angle is sometimes advantageous, and it does not matter in what direction the antenna points. Little directional difference is noted in reception, except in special and long antennas.

"Antenna length," he sums up, "is a compromise between loudness of signals and freedom from interference."

The public trend is no longer for distance, but quality of reception, he believes. If, however, one wants to astonish his friends with a long distance record, he explains, let him erect a "whale of a long antenna," or, use a very sensitive, many-tube receiving set, or both, and pile up a record. Receiving sets using electron tubes work well with indoor antennas or loops, the latter aiding in directional effects, but these antennas are relatively weak and therefore the signals must be amplified, he explained.

## A Sure-Fire Reflex

(Continued from page 15.)

then be replaced by smaller sized instruments. The neutroformer would be disassembled and the condenser mounted in the same place. The transformer coils, however, would be mounted in the space directly back of the crystal detector to conserve space. This would make room for the A and B batteries in the bottom of the cabinet. The A battery in such case would, of course, be made up of flashlight batteries.

Such a set may be taken to the summer camp and will provide plenty of entertainment on the hike or at the fireside. A portable wire wound on a good sized spool with a couple insulators will be about all that is necessary for an antenna.

The writer would be pleased to hear personally from anyone who builds this set and offers to answer any questions relative to troubles encountered in getting it into operation.

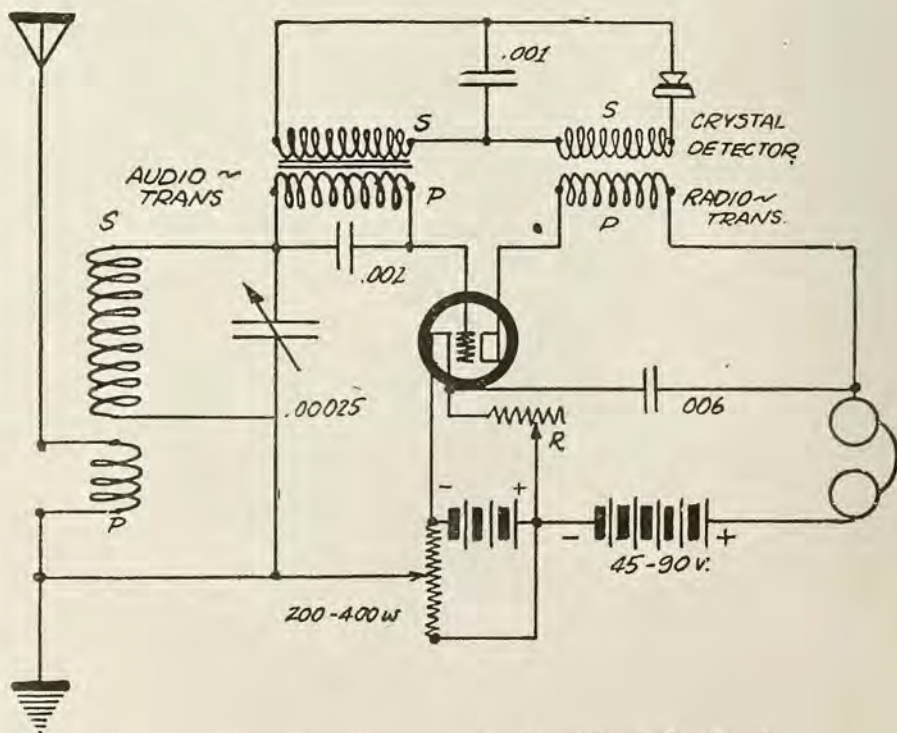

Figure 7. The wiring diagram of the Sure Fire Reflex Receiver.



# Pick-ups and Hook-ups by our Readers



THE business of choosing the letters to be used for publication in the Pickups Pages is getting to be quite a problem. It is a wonderful sight to see all the letters sent in by fellow fans offering suggestions and contributing hints, lists, stories and other matter, nearly all of which say in the last line of their letters, I hope I may be able to see in print in your next issue.

As much as we'd like to, we can't print all of them. Sometimes it is hard to have to turn down a nicely arranged list, or a little suggestion that, while it may be trivial in nature, carries with it a good idea.

So if you meet a fellow wearing a little button about  $\frac{3}{16}$  of an inch wide, with the following appearance:



*This is the emblem which says that a fellow has contributed something to the common good of the Dial Twisters. Do you want one? Does your record entitle you to one?*

you will know that he has contributed a list of stations that was meritorious; that he submitted a good suggestion that we have on file to refer to some fan that needs it, or that he has done other good work for his brother Dial Twisters.

As a matter of form, the fellows who get their names and contributions in print will be given a button as well, they having contributed something of value.

We sent out a few dozen of these little buttons as an experiment to various "fans" who sent in lists and got some of the following replies:

Received your emblem this morning and I felt prouder than the town constable when the office force asked me what I got it for.

Everybody wants to know how to get one.

... the suggestion which I sent you some time ago with reference to the mounting of homemade spider-web coils, which was acknowledged with your little button, certainly makes me very happy. I showed the idea to several of my radio friends, who scoffed and laughed until you told me that the idea was a good one and gave me the button to show your appreciation.

CONTRIBUTORS		
C. A. Williams	J. J. Drey	C. R. Williams
DIAL TWISTERS		
Name	Address	Circuit
S. J. Craig	1390 12th Ave., New Westminster, B. C., Can.	Honeycomb
H. K. Hathaway	441 Brunswick St., Halifax, N. S., Can.	Honeycomb
John Sabiston	Bay Shore, L. I., New York	Atwater Kent
George A. Holly	10214 Adams Ave., Cleveland, O.	Erla Triplex
Mr. A. C. Hart	2326 Lawrence Ave., Chicago, Ill.	First Tube
T. W. Robinson	Britton, Okla.	Three Circuit
C. W. Nestler	Flaxton, N. Dak.	Single Circuit
J. P. Cooper	c/o Southland Cotton Co., Memphis, Tenn.	Cockaday
Ray Ellis	Durant, Ia. (Cedar County)	Reinartz
John Escher	Sprang Lane, Englewood, N. J.	Single Circuit
A. P. Smith	RFD No. 8, Bangor, Me.	Ultra Audion
Richard H. Starkie	950 St. Marks Ave., Brooklyn, N. Y.	Reflex 1 Tube
C. B. Gannon	1731 Ensor St., Baltimore, Md.	Reinartz Regenerator
Kenneth B. Glass	144 S. Mt. Vernon Ave., Uniontown, Pa.	Reinartz Regenerator
E. Brand Boylan	1106 West 8th St., Wilmington, Del.	Single Circuit
Clarence Easton	35 S. Raymond, Rm. 320, Bradley Bldg., Pasadena, Calif.	Rosenbloom
B. Drum	59 S. Main St., Asbury Plk, N. J.	Three Circuit
E. L. Blass	716 Oakluna Blvd., Fort Smith, Ark.	Neutrodyne
M. S. Miller	1506 Jones St., Souix City, Ia.	Single Circuit
Eden W. Hollon	3096 Coplin Ave., Detroit, Mich.	Neutrodyne
Francis E. Chretien	416 W. Embargo St., Rome, N. Y.	Single Circuit
W. Eichler	4438 N. Artesian Ave., Chicago, Ill.	Single Circuit
August Strom	Miller, Ind.	Single Circuit
E. L. Ludell	Shelbyville, Ill.	Long 45
Edward Sagle	2569 N. Bouvier St., Philadelphia, Pa.	Three Circuit
Joseph Ross	1056 Greene Ave., Brooklyn, N. Y.	Honeycomb
Robert E. Boyle	133 West Div. St., Fond du Lac, Wis.	Westinghouse DA
A. M. Boyenga	Greene, Ia.	Single Circuit

While they're laughing up their sleeves, I laugh up my vest—and last laughs best because they all respect my ideas as to radio construction, and I am very sure that one of them is secretly developing some idea of his in an effort to be recognized as I am.

Incidentally, the department editor wants to say that the response to the request for information on the part of readers who have Super-Heterodyne receivers (the request was published in the March issue) has been very small indeed. We got an offer from one fellow who has a super constructed after the November issue, which was never fulfilled. Where have the rest of you been since 1898? Let's have some response!

Before you start reading the rest of the department matter, don't forget to look over that Static Puncturing Contest. We hope to get some nice lists.

THE PICKUPS EDITOR.

"Let our hookups be your guide" is the motto of Mr. J. J. Drey, who contributes the following letter, which we think is very interesting and highly instructive:

RADIO AGE,  
Gentlemen:

In the April issue of your valuable magazine you published the exceptional good results I am experiencing with the Reinartz hookup, in which through experiments I discovered a few valuable leads, to which I

attribute the remarkable results that this fateful Reinartz accomplishes.

Since your publication I am flooded with inquiries as to my hookup. My business duties throughout the day occupy the greater portion of my time, leaving me very little time for private correspondence. I greatly appreciate the enthusiasm displayed by so many of my brother fans. For their convenience I am submitting a diagram of my hookup, as I have found it through various experiments and finally discovered that the hookup in this form is terrifically loud and clear in volume and exceptionally sensitive to distance. I have received stations everywhere in the U. S. and many portions of Canada, all on loud speaker. I do not use ear phones at all.

In this diagram you will note the specifications for the winding of the coil, which I have found in this form covers broadcasting stations with wave lengths from 150 to 600 meters. I have also discovered that the single cotton-covered wire gives louder and clearer signals. The coil can be wound on any ordinary spider frame that can be purchased at any radio shop. It is also important that the plate coil and the grid coil should both be wound in the same direction, clockwise. It is necessary for clear, sharp tuning that the filament lead on the secondary radio frequency transformer should lead to the sliding or

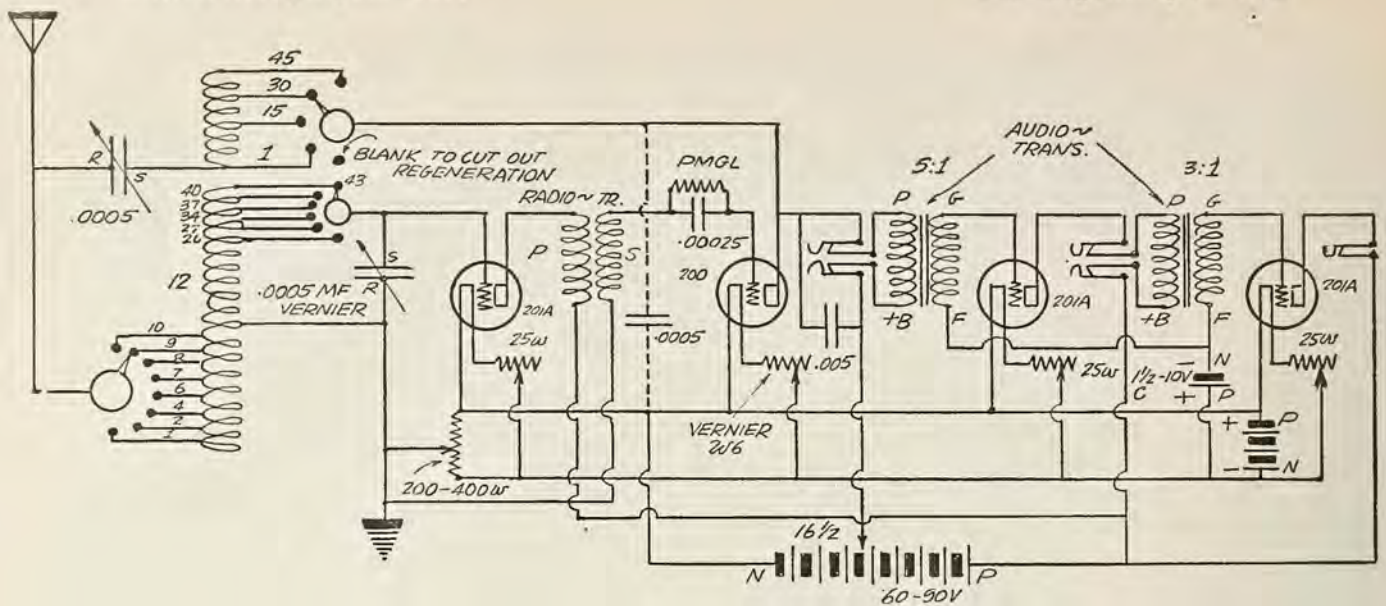

Figure 3. A diagram of the receiver described by Mr. J. J. Drey. Note especially the winding of the coils.

third arm of the potentiometer. I have also discovered that by putting a micafix condenser from the plate of the detector tube to the negative B battery lead will prevent radiation and the stations just simply walk in. Tuning must be done slowly.

In using the 6-volt storage battery, wherein the UV200 tube for the detector and UV201A's for amplifiers are used, the C battery is not necessary because of the placing of the micafix condenser across the primary of the first audio frequency transformer. The condenser from the plate of the detector tube connected to the negative B battery makes the grid circuit very quiet and clear. But where the dry cell tubes are used, it is advisable to insert a C battery of approximately  $1\frac{1}{2}$  to  $4\frac{1}{2}$  volts. This depends according to the wiring. It is also important that a vernier or carbon rheostat be used with the detector tube, because this circuit tunes exceptionally sharp and is very selective. I also recommended the shielding of the panel with a sheet of aluminum or thin copper sheet, covering the portions of the two condensers. Also, the plate should be attached to the ground connection, to prevent body capacity. In fact, my machine is so well balanced that body capacity is not known. When the condensers are attached to the panel it is important that a thin sheet of medium weight oiled paper be inserted between the shielding plate and the end of the condenser so that stator screws of the condenser will not come in metallic contact to the shielding plate.

I have found through various experiments that the proper ratio audio transformers to be used in the first stage should be either a 5 to 1 or 6 to 1; not higher. The second audio transformer should be a 3 or  $3\frac{1}{2}$  to 1. The grid leak should be variable from 1 to 5 megs. This I have found to assist greatly in receiving stations on long distances, when climatic condi-

tions change daily. Varying the grid clears the distant stations up remarkably. I have found it very important and I fully realize that every radio fan wants to reach distance. As I have stated before, I have heard practically every leading broadcasting station in the U. S., and this I know every fan desires.

I am at present experimenting with numerous new hookups, as experimenting seems to be my favorite pastime. But the fateful Reinartz is not touched. It brings in the stations clear and loud every night.

In conclusion I can say that any of my radio fan brothers who want a clear, loud, far-reaching set should follow these instructions and he will write RADIO AGE a long letter of thanks, because I have discovered that the hookups in RADIO AGE are something to be proud of.

I remain,

Yours sincerely,

J. J. DREY.

Iron River, Mich.

The Reinartz bugs will no doubt oscillate and radiate nothing but pure delight and gratitude for this generous letter of Mr. Drey's, and the department editor wants to say that we hope Mr. Drey will let us have the benefit of his later ideas and experiments.

We present herewith some data which should be of interest to those experimenting with the Superdyne receiver. Mr. M. C. Williams is connected with the Air Service Technical School at Rantoul, Ill., and has submitted some most interesting and enlightening data on the construction and choice of apparatus for this receiver.

RADIO AGE,  
Gentlemen:

Attached herewith find print and "writeup" on the Superdyne, which I am submitting to your magazine, in which I am intensely interested, and of which I never fail to get a copy.

This set has been constructed as indicated and works wonderfully in my home.

Very truly yours,

M. C. WILLIAMS.

Box 353, Rantoul, Ill.

**COIL DATA:** Secondary or stator should be 4 inches in diameter, similar in design to coils sold in Kresge's stores. Wound with 25 turns of No. 22 D. S. C. wire, commencing about  $\frac{1}{2}$  inch (one-half inch) from rotor shaft and top edge of tube.

**ROTOR OR TICKLER:** Similar in design to those sold in Kresge's stores. Wound with 18 turns of No. 22 D. S. C. wire, commencing at outer edges and winding towards center, leaving a space in center.

**PLATE REACTANCE COIL:** Similar in design and size as the above rotor. Wound with 30 turns of D. S. C. wire, commencing about  $\frac{1}{2}$  inch from top and rotor shaft hole.

**GRID AND PLATE CONDENSERS:** .00055.

**LOOP:** Very good results should be obtained by connecting the loop to the aerial and ground binding posts through a small fixed condenser. Better results, however, may be obtained by grounding the negative side of the filament and connecting a small aerial strung across the room to the stationary plates of the first variable condenser.

**TUBE ARRANGEMENT:** Tubes may be arranged in any manner to suit the fancy of the builder, but remember that the leads which carry radio frequency current must be very short and direct.

**WIRING:** The wiring of the filament and other parts at more or less ground potential should run near the front of the panel and the rotary plates of the variable condensers should be as near to ground potential as possible to reduce stray capacity from the hands of the operator. All wires from the grid and plate circuits

should be far back from the panel and separated from themselves and everything else as far as possible.

**RADIO FREQUENCY STAGE:** A great deal depends on the construction of this stage whether it really beats a regenerative detector and two-stage audio or not. The main thing to remember is to hold the radio frequency tube from oscillating when both tuned circuits are brought to absolute resonance. With the tickler winding on the rotor described above both halves are connected in series so that the windings are in the same direction on the halves. It does not really matter which direction the rotor or stator is wound as they can be shifted by turning rotor over. By reversing the coil in the plate circuit will change audibility of signals sometimes.

**OPERATION:** The operation is apt to be a bit puzzling at first. With the aerial connected, also ground, etc., set the resonator dial (condenser) to the left and the wave length dial to the right, say at about 20, and advance the stabilizer from the "zero" or full reversed position until a click is heard in the phones or loud speaker; this denotes oscillation. Work slowly on the edge of this point, coming forward with the resonator and wave length dials until the old familiar squeal of a station is heard. Tune this in at the loudest and then reduce the stabilizer little by little and follow up with the resonator keeping the squeal at a low tone until finally the squeal is entirely lost and speech comes in clear. Then try the wave length dial for micrometer adjustment to refine the music or speech. Experience alone is the best teacher with this sensitive receiver.

**PARTS USED:** 1 special coupler, stator and rotor; 1 plate inductance; 5 rheostats; 5 freshman condensers; inch; 1 panel, 7-inch by 26-inch; 2 6 sockets; 1 cabinet, 7-inch by 26-inch; 2 variable condensers, .00055; 2 transformers, first and second stage; 3 3-inch white dials; 7 binding posts; 1 input push and pull modern transformer; 1 output push and pull modern transformer; necessary bus-bar and spaghetti. Total cost, about \$60.00.

**RANGE:** Unlimited. Easy to tune western stations as Los Angeles, etc. (Chicago with loud speaker without resorting to the usual head phones first); volume from KFI resembles a phonograph. Most sensitive set known for the number of tubes used, outside of the super-heterodyne.

**GRID LEAK:** Some tubes have a tendency to block or choke when resonance is passed. This condition may be removed by touching the moistened finger tip to the grid terminal on the socket of the detector tube. However, if this becomes annoying it may be further remedied by using a better grid condenser or using a grid leak. One very important thing to remember is never connect a grid leak across the grid

Figure 1a. The Superdome receiver described by Mr. Williams. The lettering on the circuit diagram bears the following meanings: A.A. antenna tuning condenser preferably 23 plates; B. rotor tickler for negative feedback; C. the stator. The coils B and C may be a recond varicooper, the coils being wound as specified in the accompanying text. A is the tuning condenser 23 plates 0.0005 microfarads; A in plate circuit of radio frequency tube is the reactance condenser 0.0005 mfd. maximum; F is the reactance coil. The reactance condenser and coil can sometimes be substituted for by a good variometer with equal results. I grid condenser .00025 MFD for 200 tubes and WD's and should be .0005 for UV199; G. grid leak, preferably of the pencil mark type; D the rheostat; J amplifying transformers; 1PP and 0PP the input and output push-push transformers; and the remaining by-pass condensers I, which should be .100 microfarads fixed mica type.

A set of this type gives complete control of oscillations, increases range, reduces radiation and tunes sharply. In recent tests, the set in actual working comparison showed an audibility ratio of 10,000 in some cases over a standard regeneratives audibility of 85, on the same signals.

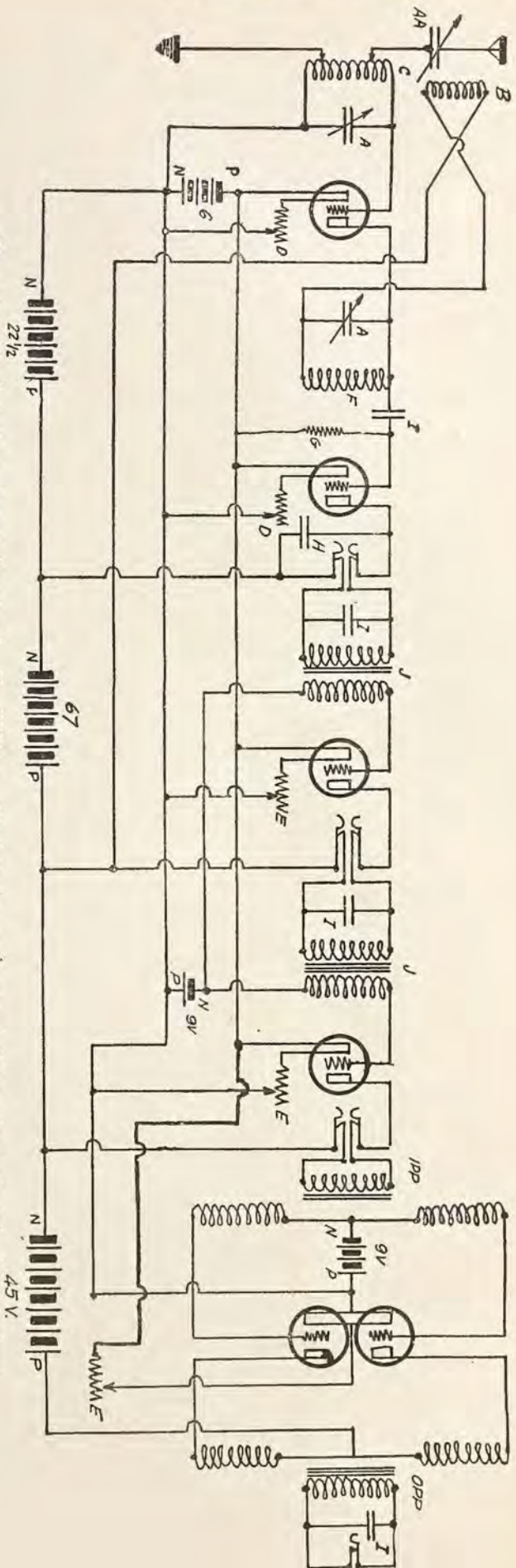

insulating condenser. If a grid leak is needed it should be connected from the grid terminal of the detector socket to the positive terminal of the same socket. From two to three megohms are used with hard tubes while it is not necessary with soft tubes. The grid condenser should be about .00025 and well insulated.

LEGEND OF FIGURE 1

- AA—Antenna wave length condenser for balancing. After once adjusted for the particular type of antenna need not be touched again. Many use the small fixed condensers after the one best suited has been tried out.
- B—Special coupler, stator has 25 turns No. 22 D. S. C. wire, 1/2 inch from top edge and rotor shaft. Tube 4 inches in diameter.
- A—Variable condenser .00055 for wave length of station to be tuned in.
- C—Rotor, feed-back stabilizer, 18 turns on each side No. 22 D. S. C. wire, connected on inside in series, leaving space on outside between windings.
- F—Plate inductance, 4-inch tube, wound with 30 turns No. 22 D. S. C. wire, 1/2 inch from top edge and rotor holes, if an old variocoupler stator is used.
- E—Rheostats.
- D—Rheostats.
- G—Variable grid leak.
- H—Fixed condenser, .00025.
- I—Fixed condensers, .002.
- J—Sheltran transformers, same ratio, 9 to 1.
- K—Modern push and pull transformers.

LEGEND OF FIGURE 2

- Resonator—Condenser .00055.
- Stabilizer—Special coupler with stabilizing rotor.
- Wave Length—Condenser .00055.
- Rheostats—For amplifier and detector tubes. 3 and 4 rheostats for two audio tubes. 5 for the two P. and P. tubes.

LEGEND OF FIGURE 3

- 1—Resonator condenser.
- 2—Special coupler and stabilizer.
- 3—Wave length condenser.
- 4—Plate resonance coil.

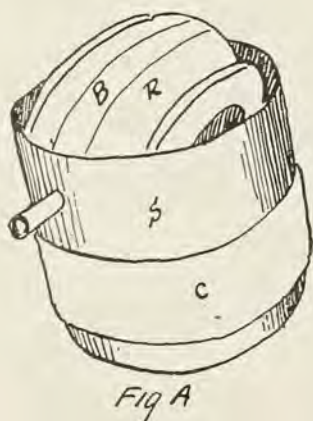

Figure 1a. Arrangement of the coupler and plate coils.

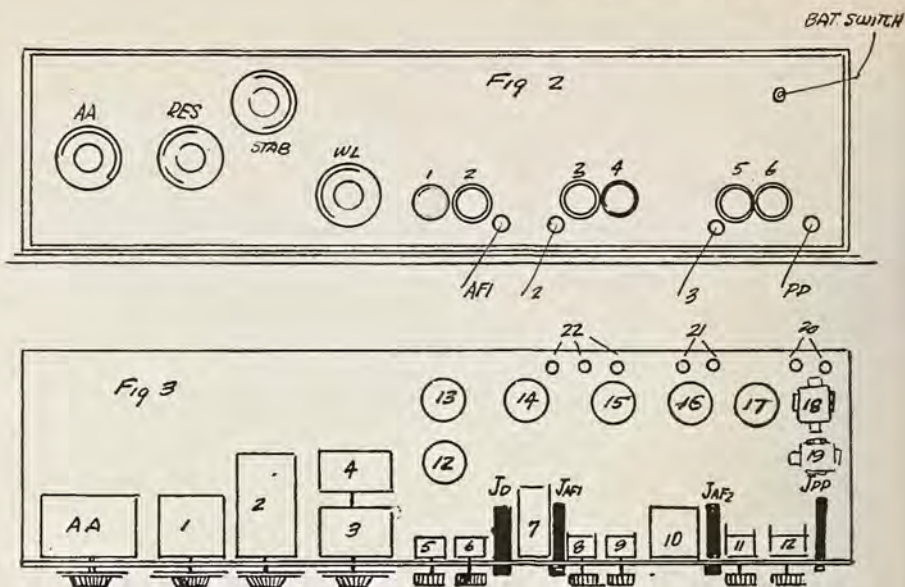

Figure 1b. The layout of the Superdyne receiver.

- 5—Bradleystat for amplifier tube.
- 6—Bradleystat for detector tube.
- 7—First audio transformer.
- 8—Rheostat, first audio tube.
- 9—Rheostat, second audio tube.
- 10—Second audio transformer.
- 11—Rheostat for two push and pull tubes.
- 12—Radio amplifier tube.
- 13—Detector tube.
- 14—First audio tube.
- 15—Second audio tube.
- 16 and 17—Push and pull tubes.
- 18 and 19—Push and pull transformers.
- 20—"C" battery binding posts.
- 21—"A" battery binding posts.
- 22—"B" battery binding posts.
- 23—Jack for first audio stage.
- 24—Loud speaker jack.

NOTES

With the old-fashioned VT1 tubes as detector and all stages of amplification this is the most sensitive set obtainable which will work under the existing circumstances. Twenty feet of wire strung around the room under molding or around picture, or straight run through attic, makes a very good aerial. But the

best aerial is a single wire about seventy feet in length.

Do not touch the wave length condenser after it has once been tuned or balanced with the aerial, for this will throw the entire set out of tune.

Stations one thousand miles can be heard at any time through any interference and loud enough to be heard on a Brandes Table Talker one city block.

Very much care, indeed, must be taken in the wiring and in the selection of instruments. It is always better to select the very best instruments and save the later purchase, for eventually better grades must be installed.

If we were to judge from the correspondence of the technical department with reference to the Superdyne circuit, we would like to say that Mr. Williams' data is most welcome. Many fans have been asking for more detail with regard to amplification and panel layout, together with a complete list of parts—and here it is. Mr. Williams enclosed a well designed blueprint of the circuit (Figure 3), with instructions as to the layout of the receiver, and we are sure that he will be amply rewarded for his troubles in the grateful thanks of many DT'S.

RADIO AGE,  
Gentlemen:

Since publication of my letter in the April issue I have received a number of letters from fans asking for the circuit diagram, etc.

I am therefore sending it to you herewith.

Sincerely,

CLARENCE R. WILLIAMS.

7 East St. S., Janesville, Wis.

Mr. Williams' contribution incorporates some very good ideas on a simple, efficient receiver, and the Technical Editor thinks very highly of his letter. We hope the fans will appreciate his efforts in their behalf.

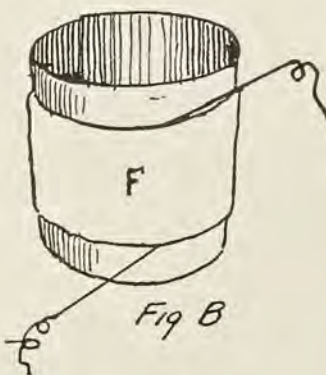





Half of them I received on a loud speaker.

Sincerely yours,  
JOHN SABISTON, JR.

Bay Shore, Long Island, N. Y.  
Here's the list:

KDKA, KFKX, KOB, KOP, KSD, KYW, PWX, WAAF, WAAW, WBAH, WBS, WBAV, WBB, WCAE, WCAD, WCAP, WCBD, WCC, WDAF, WDAP, WDAW, WDAY, WDT, WEA, WEAN, WFAA, WFAY, WFI, WGI, WGR, WGY, WHAM, WHAS, WHAZ, WHB, WHN, WIP, WIAR, WIAX, WIZ, WIY, WKAQ, WLAG, WLW, WMAF, WMAQ, WNAC, WOS, WOAW, WOC, WOO, WOR, WPAB, WPAH, WPAD, WRC, WSD, WSB, WTAS, WTAM, WSAI, WWJ, WQAM, WMAK, WCAL, WWSY, WIAD, WPAB, WPAB, WCE, WHAA, WTAY, WABT, WBBR, WQAL, WEAY, WGAY, WJAN, WRAX, WMC, WRM, WQAN, WMAV, WQAE, KMO, WDAH, WRAY, WWAD, WBBG, KZN, KFAF, WRR, KFEX, WGAG, WDBC, WBL, KFCH, WFAV, WRK, WDK, KFKB, KFI, WCAH, WSAW, WSAQ, IXAL, 2BLX, 9XAT, 5ST, 9ESI, 6KW, 8XS, IXAE, 2XZ, 9BM, NRE, NRG, 2KW, KOV, KFGZ, KGW, 9CY, WGN, WBAK, WRW, WGAZ, WJAS, WRAX, WTAN, WMAV, WQQ, WCBR, WFAT, WABL, WSCA, WCAQ, WIAO, WGAW, CHXC, CFAC, CKY, CKCK, CKCH, CJCN, CFCF, CHYC, CHCB, CKAC, CFCF.

One hundred and fifty exactly. Not so bad for four months. What say?

RADIO AGE,  
Gentlemen:

Your seven pages of "pickups" in the March issue of RADIO AGE have sure made me a Dial Twister fan. I have heretofore skipped this section, thinking it to be of no interest to a dried up old man nearing the half-way post, but, oh, boy! it's the meat of the publication; that is, after one has grown weary of trying to build every new circuit that comes out and settles down to really enjoy radio reception as brought in by a real outfit that stands well up toward the top of the list of consistent receivers. I refer to the Erla three-tube reflex circuit.

Reading the letter from G. S. Baird, Suffern, New York, and your comments on same have prompted me to

write to you and give you a log of what I have gotten out of my set. Before reading Baird's letter I had not thought very much about the performance of my set. I was perfectly satisfied with what it was doing and getting a lot of enjoyment out of it. After looking over my log I felt like writing to John Sabiston and asking for that extra bakelite crepe. I mean the one he could not use last month. I think I could present it to my friend Baird. A copy of my log is attached; it shows 94 stations. Each one has been heard at least two times. I have 20 more that have been heard only once, so they are not entitled to a place on my honor list. Stations up to 100 miles distant can be brought in almost at will, provided they are on the air and no other station is working on the exact wave. I have a verification of reception from nearly every station listed.

In building my set I used the parts recommended by the Erla people and followed their blue prints to a hair. If this is done I cannot see why anyone had trouble with this circuit, but I know a great many have.

Antenna consists of 30 feet of solid No. 12 wire hung in the attic with lead-in taken out of attic window and dropped down to window in living room (17 feet) ground of No. 12 wire 18 feet long to a water pipe.

One hundred and twenty volts on the plates supplied by a homemade Edison element B battery.

I am an Erla fan and have built every circuit they have ever devised and have had wonderful results from all of them.

I would be glad to pass on to faltering fans what little I know about these Erla circuits.

I do not expect you to give space in your publication for this long, rambling letter, but if you can spare the time would like to hear from you as to what you think of the work the Erla Triplex is doing for me.

Thanking you for the mighty inter-

esting department in RADIO AGE, I am,

Respectfully,  
GEORGE A. HOLLY.

10214 Adams Ave.,  
Cleveland, Ohio.

Mr. Holly's list:

WCX, KOP, WSAJ, WIAS, KDKA, WCAE, WEAQ, WBAV, WKAR, WSAZ, WGR, WPAB, WMAK, WSAI, WLW, CFCF, WHAM, WABC, WBAK, WKC, WIAD, WFI, WDAW, WIP, WOO, WRAX, WDAP, WJAZ, WMAQ, WCAP, WRC, KYW, WTAY, WGBD, WHAS, WTAS, WOR, WRM, WGY, WEAM, WAAM, WHA, WHN, WIY, WJZ, WEA, WHAZ, WPAH, WBT, WOC, WCAZ, WBZ, WHAA, WCK, KSD, CFCF, CHYC, CKAC, CFCF, WOAN, WEAN, WIAR, WBBF, WMC, WHAT, WNAC, WOS, WSY, WMB, WCAL, WOL, WLAG, WDAF, WHB, KFLZ, WAAW, WOAW, KFKB, WPAK, CFCR, WFAV, KFKX, WKY, WFAA, WBAE, WVAQ, PWX, KDYL, CHBC, CJCA, KHJ, KFI, CKCD, WWJ, 8BZS, 8BRK, BJY, 8BMK.

RADIO AGE,  
Gentlemen:

The more I read of your magazine, the more convinced I become that you have selected the correct slogan, "Let Our Hookups Be Your Guide."

From your October issue I built "Your First Tube Set" and was very much pleased with the results obtained with it. Everything went along nicely until WJAZ broadcasting on 448 was changed to WGN, broadcasting on 370. Then my troubles began. It cut me out of WDAP, and there are parts of their programs which I enjoy very much.

I began at once to look through your magazine for help and found your eliminator in the January number. I constructed this experimentally, mounting it on a pine board, and while I know this is not what would be termed proper construction, yet I am able to cut WGN entirely out and listen to WDAP without interference. Last night when KYW, WGN, and WDAP were going full blast, I eliminated WGN entirely and brought in WDKA without any interference.

I sincerely appreciate the helps which your magazine rendered.

Yours very truly,  
A. C. HART.

2336 Lawrence Ave.,  
Chicago, Illinois.

RADIO AGE,  
Gentlemen:

In your November issue you gave instructions for the building of the old standby, the three-circuit regenerative receiver. I just happened to get a copy of that issue.

I knew absolutely nothing about radio—had hardly seen a set in my life, and had never tuned one. So I hesitated considerably before I decided to build a set. However, the bug had me—so I followed your instructions and built the three-circuit.

It was by this time nearly Christmas, and it took me some little time to get the set to operate properly—so that I have not actually been using it very long. Nevertheless, I have now heard 139 broadcast stations, and am adding new ones regularly.

## THE IHC RADIO CLUB

IS COMPOSED OF EMPLOYEES OF THE INTERNATIONAL HARVESTER COMPANY OF AMERICA AT OKLAHOMA CITY, WHO OWN AND OPERATE RECEIVING SETS THESE BROADCAST LISTENERS WANT TO EXPRESS THEIR APPRECIATION OF WORTHWHILE PROGRAMS THESE CARDS WILL BE SENT ONLY TO STATIONS BROADCASTING OUR CONCEPTIONS OF HIGH CLASS PROGRAMS SUCH AS WE WISH TO ENCOURAGE THE FACT THAT YOU HAVE RECEIVED THIS CARD INDICATES OUR APPROVAL AND APPRECIATION OF YOUR PROGRAM

## I H C RADIO CLUB APPLAUSE CARD OKLAHOMA CITY, OKLA.

STATION RADIO AGE

APR 2 1924

YOUR PROGRAM OF EVERY MONTH

RECEIVED AND APPRECIATED BY ME

TYPE OF RECEIVING SET YOUR 3 CIRCUIT

RECEPTION WAS ENTHUSIASTIC

PLEASE THANK THE ARTISTS CONTRIBUTING

REMARKS YOUR DIAGRAMS AND HOOKUPS

ARE THE BEST EVER

SIGNED

P. A. Robinson

ADDRESS BRITTON, OKLA.

Look what RADIO AGE got! In a little while we'll be considered a regular broadcaster—applause cards 'n everything!

These 139 stations are located in 34 different states, the District of Columbia, Mexico, Cuba, and four provinces in Canada. To go into a little more detail, they are located as follows: 1 in Alabama, 3 in Arkansas, California 6, also 6 in Colorado, 1 in Arizona, 1 in Florida, 1 in Georgia, a dozen in Illinois, 1 in Indiana, 7 in Iowa, 6 in Kansas, 1 in Kentucky, 4 in Louisiana, 10 in Missouri, 6 in Minnesota, 1 in Maryland, 5 in Michigan, 1 in Massachusetts, 1 in Mississippi (the only one in this state), 8 in Nebraska, 4 in New York, 2 in North Dakota, 2 in New Mexico, 1 in North Carolina, 1 in New Jersey, 6 in my home state of Oklahoma, the same number in Ohio, 1 in Oregon, 4 in Pennsylvania, 1 in South Dakota, Texas holding the record with 14, 3 in Tennessee, 2 in Wisconsin, and 1 in Wyoming. This is all—in the U. S., except 1 in Washington, D. C. Then my records show 1 in Havana, Cuba, 2 in Mexico City, 2 in Calgary, 1 in Winnipeg, 1 in Regina, and 1 in Toronto, these last five being Canadian stations.

How's that for a log over the time I have been using my set? Oh, by the way, I forgot to tell you that I am a traveling man, and am away from home about half the time.

I don't claim to be an expert as yet in the operation of a set, but I'll undertake to tune in any one of forty or fifty of the principal stations in the country as quickly as anyone. My record for one evening is forty stations, 29 of them less than a thousand miles distant—and these over a thousand miles away: WGY, Schenectady, 1,375 miles; PWX, Havana, 1,225 miles; KDKA, Pittsburgh (not re-broadcast from Hastings), 1,050 miles; KFI, Los Angeles, 1,200 miles; KHJ, Los Angeles, 1,200 miles; KPO, San Francisco, 1,410 miles; KGO, Oakland, 1,410 miles; KLX, Oakland, 1,410 miles; CFCN, Calgary, 1,375 miles; WCAE, Pittsburgh, 1,050 miles, and KGW, Portland, 1,510 miles. Portland is generally regarded as a "dead spot" here, very few ever hearing them. I forgot to try, or I could have added KFSG at Los Angeles to the above list.

Does this let me in to the "Dial Twisters"—or do you want more? I can very easily better this night's performance.

Sincerely,

T. W. ROBINSON,

Britton, Ok'a.

RADIO AGE,  
Gentlemen:

I am an ardent reader of your good magazine and am very desirous of becoming a Dial Twister. I noticed that you have published several records of some fans who operate three-tube, three-circuit sets and who I think ought to be eliminated entirely because anyone with such a set ought to consider the records that they send in very poor. I am an ar-

dent backer of the single circuit set. Please consider the much-sought-for record of one who operates an old moth-eaten homemade single circuit. Although I have four tubes, I used but the detector tube when I got the following:

WLAG, WCB, WDAY, WJAZ, WOC, WHB, WCAL, WTAS, KDKA, KFI, WDAP, KDZR, KFJR, WWAE, CFCN, WFAA, KHJ, KPO, CJCA, KLZ, KJO, CHCE, WBAP.

I used but four and a half hours and quit at 11:30. The total mileage was between nineteen and twenty thousand miles. How's that for an old detector tube under the ideal conditions of a noisy generator of the local power plant and several other single circuit users?

Don't fail to make your queries and letters conform with the rules published in the May, 1924, Troubleshooter section. There is no excuse for not complying with rules such as were found necessary to assure all our readers an equal chance of this service.

We have a number of questions on hand at present that have not been answered because their writers did not observe the rules as they were specified. Due to the great number of questions we receive, this has been found necessary, in order that justice may be done to all of them.

If you don't know what we are referring to, read the notice published on page 42, Troubleshooter section of the May, 1924, issue.

Technical Editor.

This all happened on the night of January 20, a Sunday night at that.

Very truly yours,

CARLOS W. NESTLER.

Flaxton, N. D.

Mr. James P. Cooper of Memphis, Tenn., care of Southland Cotton Company, writes of his experiences with a Cockaday set, and tells how he learned to operate the set so as to get a list as long as a music roll. He also says he picked up 13 stations in 39 minutes, or a station every three minutes. Some speed!

Ray Ellis of Durand, Ia., Cedar County, writes of his success with the Reinartz, and states: "The Reinartz hookup means to the broadcast listener more volume, greater distance, and wonderful selectivity."

John Escher of Spring Lane, Englewood, N. J., says: "I am sending you a log of stations heard on a set (single circuit)

which was made by myself and a friend. I am 12 and he is 14.

"Johnny operates under restrictions. All stations were received before 9:30 P. M., as I am not allowed to stay up later."

What surprises the gentle reader is that Johnny has a list of 73 stations, including reception from United States, Canada and Cuba. Great!

A. P. Smith of R. F. D. No. 8, Bangor, Me., sends us a letter enclosing a long list of calls heard and wants to be a Dial Twister. Sureuff.

Mr. Richard H. Starkie sends in a long list of stations heard on the loud speaker with a single tube reflex circuit. His list totals 50 stations from every part of the country.

Clarence B. Gannon of 1731 Ensor Street, Baltimore, Md., and Kenneth Glass of 144 South Mount Vernon Avenue, Uniontown, Pa., both send in a list of suggestions on the Reinartz Audio Regenerator, which we will present in next month's Pickup pages. They certainly are appreciate, but due to the fact that they came in just as we are about to go to press with this issue, we could not print them.

E. Brandt Boylan of 1106 West Eighth Street, Wilmington, Del., "The First City of the First State," sends in a list of great length compiled from receptions on a Bachman single circuit receiver. He has several 2,000-mile receptions to his credit. FB OM!

To conclude this month's Pickup Section, we print this letter from a California fan who must be living near some movie lot where they make comedies.

RADIO AGE,  
Gentlemen:

First of all I want to tell you that most radio magazines are NG. Savvy? For instance—a hookup form (name of magazine upon request) knocked my tube colder than King Tut's grand-dad, and also gave my ears a vacation. Another hookup from the same magazine made me think my antenna had fallen on a trolley wire; in fact, my phones were doing a 1921 shimmy, and danced around like Indian clubs.

Yes, ma'am—they sure did have chills. Just as I was about to take the axe and make my radio set look like the ZR-2 wreck, with the exception of the Japanese earthquake, a thought came to me, saying: "Stay at it until you do get a good set."

All right, I says to myself, I'll do it! So I grabbed my hat, and started for a magazine and book store, hitting on all two; got there in ten minutes, just before closing time, 6 o'clock, and purchased a magazine I had never heard of before—RADIO AGE!

I rushed back home, as I knew it was silent night for Los Angeles, hooked up your Roses-in-bloom circuit, only to find that my A battery

(Continued on page 53.)

# PMGL

By THE TECHNICAL ASSISTANT

**R**EGULAR readers of this magazine, when referring to circuit diagrams, no doubt have noticed the letters PMGL next to the zig-zag line denoting the grid leak, and without question they wonder what this means. It has probably been given different names to suit the lettering, but the matter stands that it is very important.

There are, perhaps no other units in the receiver that make more trouble, noises and are given less attention than the grid leak and condenser. Just because an experimenter can wander into most any radio store and purchase something that masquerades under the title of grid leak, it does not mean that this little unit is not important. The sooner the DX "fan" finds out that the grid leak is one of the factors in the success or failure of his receiver to be sensitive, the more distance his set will cover.

A good grid leak must have the right resistance for the type of tube used, must not assume different values with different weather conditions, and must make good contact. So simple that it is considered unimportant.

## Pmgl

The pencil mark grid leak is probably the most simple and effective type on the market—if it is properly constructed. A leak of this type is illustrated in Figure 1, and consists of nothing more than a strip of insulating material with a pencil mark drawn between two good contacts—hence the name "Pencil Mark Grid Leak."

When making a leak of this kind, do not use a fiber, paper or cardboard strip. These things are useless, because they soak up moisture in wet weather, and every time it gets damp the leak absorbs moisture and you have two grid leaks instead of one. The moisture furnishes one resistance, and the pencil mark another, with the result that the set is unstable, finicky, and hard to tune, often fails to stop oscillating, and many other disagreeable experiences are encountered.

Procure a piece of hard rubber or a strip of bakelite-dilecto about  $1\frac{3}{4}$  or 2 inches long and  $\frac{1}{2}$  to  $\frac{3}{4}$  of an inch wide and sandpaper the surface you are going to use. Do it in the same manner as you would grain a panel except that you re-

frain from using the oil to wipe the excess dust off.

## Good Contacts Essential

Drill two holes to fit the type of machine screws you intend to use; the size is not important. After this has been done, take a good soft pencil, a No. 2 or B is satisfactory, and make a good heavy smudge of pencil lead around the hole made for the machine screw, enough to allow a good margin around a tinfoil washer. Rub the lead good and hard, and let it be big enough to come out around the washer a considerable distance— $\frac{1}{8}$  inch is not too much. Do this for each side as illustrated. Now place a soldering lug and a tinfoil washer on the machine screw, and insert the screw into the hole. Tighten down the hole unit good, making sure that good contact is made.

Connect the wires by soldering them to the lugs as furnished. Be careful not to let the flux, rosin or whatever agent you are using for soldering run on to the grained strip. Turn on the tubes and plug the phones on the detector stage. The set will very likely be cranky and unstable, will howl and squawk at the least touch, and will give weak and wheezy signals. This is, of course, only when the grid wires are so arranged that they do not touch the panel or mounting board or any part of the cabinet.

One can classify this matter as a sort of unintentional grid leak, and the symptoms are that the leak, when connected and adjusted, has no effect upon the action of the tube. This means that the tube socket is poor, the grid wire is touching something that is causing the trouble, the panel is bad or that the grid condenser is faulty. Be cautious about buying moulded mud grid leak mountings, as they often are grid leaks in themselves and defeat the purpose of the one you are seeking to adjust.

## Adjusting

Adjusting the grid leak of the pencil mark type is very simple. The leak is connected in the regular manner across the grid condenser or from the G post to the positive filament, and if the set is OK and the tube is normal, the set will be

cranky as mentioned before. Now take the pencil and draw a firm line between the two edges of pencil mark sticking outside of the tinfoil washer. The action of the set will be very much different.

Experiment by making the mark a little heavier, and you will soon find the point where the tube settles down to business and operates at maximum effectiveness. Too much leak will cause the set to oscillate too readily, giving the operator the impression that it is very sensitive, when it is really dead. In either case, the leak is adjusted by lowering the resistance or raising it until best action is obtained. Incidentally, some of the C300 or UV200 tubes often function without a leak at all. The other high vacuum valves invariably require leaks.

## Adjustable Leaks

Adjustable leaks are very handy and convenient if they are so constructed that they hold their values. If this is not so, the leak will have to be tinkered with constantly. Some of these leaks fit the usual clips, and others are so designed to mount on a panel. Personally, the writer finds that the panel mounting types nearly always cause trouble in the hands of beginners, because they mount them too close to other units, binding posts and parts. Also, it is not good design to run wires of the grid circuit near to the panel, as hand capacity and critical tuning is nearly always the result. The grid leak in connection with the grid condenser should be mounted directly on the G post of the tube socket, which should be of good hard rubber, porcelain, pyrex or other insulator of high dielectric strength. Mount them as close as you can mechanically. The reward comes later in the form of steady signals.

## Noises

Noises in sets can often be traced to poor contact in grid leaks and grid condensers. If this happens to a sealed-in glass tube leak—throw it away, and use a new one. However, before you discard the unit make positive that the trouble comes from the inside and not from the clips.

(Continued on page 36)

Figure 1. An easily constructed variable grid leak that gives good results. The leak is adjusted by making a mark between two contacts, the size of the mark and the heaviness determining the resistance. If the value is too low, more pencil should be applied; if it is too high, it can be lowered by erasing it lightly with a pencil eraser.

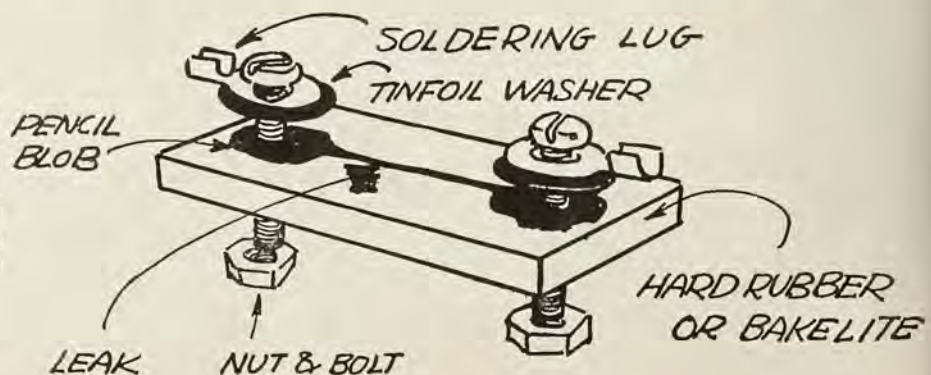

*Here's the Best Hookup Book Ever Printed!*

# RADIO AGE ANNUAL ILLUSTRATED for 1924



**SPECIAL FEATURES**

Simple Crystal Set	Reinartz
Long Distance Crystal Set	Haynes
Your First Tube Set	Hopwood
Kopprasch Circuit	Cockaday
Erla Reflex	Neutrodyne
Kaufman Tuner	Three-Circuit Tuner
Grimes Inverse Duplex	Super-Heterodyne
Two Stage Amplifier	Simple Radio Frequency
Junior Heterodyne	Ultra-Audion
One Tube Loop Aerial	Rosenbloom
Wave Trap, Filter and Eliminator	Push-Pull Amplifier
Loading Coils	Portable Reinartz
Transformers	Wave Meters
Battery Charger	Two-Circuit Crystal

Forty-five Complete Articles Dealing with Every Phase of Radio.  
One Hundred and Fifty Isometric Picture Drawings and Diagrams.  
Dozens of Helpful Hints.—The Best Hookup Book Ever Printed

**Published by Radio Age Inc.**  
**500 N. Dearborn Street**  
**Chicago, Ill.**  
**PRICE ONE DOLLAR**

*Detach this Coupon, fill in, pin  
a Dollar Bill to it and mail  
TODAY!*

*If Paying by Check Add 5 Cents for Exchange.*

RADIO AGE, Inc., 500 N. Dearborn St., Chicago, Ill.

Gentlemen: Attached find One Dollar (\$1) for which kindly forward me by return mail one copy of RADIO AGE ANNUAL FOR 1924. If not satisfied with it I will return it to you within three days and you will refund my money.

Name .....

Address .....

City ..... State .....



Kadel &amp; Herbert Foto

### RADIO REPLACES SCHOOL TEACHERS

The experiment of teaching school children by means of lectures broadcast has been inaugurated by the London County Council and a loud speaker installed in many schools in London. The first lecture was broadcast by Sir Walford Davies on "Musical Appreciation." Photo shows pupils at the Hugh Wyddleton listening to the lecture.

Just because you have a good grid leak, don't think you can use any makeshift for a grid condenser—and yet expect the set to work decently. It won't do. Use a good sealed-in mica condenser, tested to the capacity you want, and avoid the use of paper or other contrivance that radio engineers classify as "Gyp" stuff.

#### General Suggestions

Don't expect your set to work decently with a thin layer of soldering flux all over the parts. They are grid leaks and cut down your efficiency. Inspect the leak and condenser often, because even the best parts go wrong occasionally. Avoid the use of carbon paper grid leaks. If you use the cartridge types, get a whole set of them from .5 megohm all the way up to 10 megohms. Try them all out on the tube until you find the best one. Some leaks have a metal seal end, with metal dust flashed on the inside, and then sealed. Such leaks are almost always good. The glass sealed type with the carbon paper leak are more apt to be defective, as only too often they are carelessly assembled and absolutely "NG" for radio work.

Last but not least, after you've found the right resistance, *leave it alone*. Don't be nervous and continually "hike" the leak. You will always end up where you started, and often a good adjustment is lost by not refraining from tinkering.

#### Audio Amplification

Three stages of resistance-coupled amplification should give slightly greater amplification than a two-stage transformer-coupled amplifier. The quality, of course, will be much better. The B battery voltages, except on the detector, should be from 90 to 180 volts.

### Important Super-Heterodyne Factors

(Continued from page 7.)

is found in the same way. The highest of the normal broadcast waves will not be over 600 meters. This will have a frequency of 500,000 cycles. There is a difference between this and the 100,000 cycles of the intermediate frequency amounting to 400,000 cycles, which is equal to a 750 meter wave. By this method, the range required for the oscillator is obtained, and in a like manner the range of the oscillator required for other intermediate frequencies is obtained.

The most simple oscillator for the novice to make is that designed by Hartley, the circuit of which is shown in *Figure 2*. It can be made by taking an ordinary vario-coupler and stripping it of all the windings. The size of the tube will, however, have much to do with the winding required, so that several specifications will have to be given in order that one may adapt a coupler of any size to the purpose. The rotor is to be used for the pickup coil, but in any case the winding will be the same. Eight turns of No. 18 double silk insulated wire should be used.

For the 3,000 meter intermediate wave, the windings should be as follows: If the tube is 3 inches in diameter, with plenty of winding space, it may be wound with 49 turns of No. 18 double silk insulated wire. This will require approximately  $2\frac{3}{16}$  inches of winding space and the tap is taken out at the 25th turn. It may also be wound with 48 turns of No. 20 wire, in which case the winding space will have to be  $1\frac{3}{4}$  inches. It may also be wound with 42 turns of No. 22 wire, if

the winding space is short. In any case the tap is taken from the center of the coil.

If the tube happens to be 4 inches in diameter, then it may be wound with 36 turns of No. 18, 33 turns of No. 20, or with 30 turns of No. 22. As mentioned before, the rotor has only 8 turns of No. 18 regardless of the size of the tube.

To wind the tube for a 6,000 meter intermediate wave use 42 turns of No. 18 if it is a 3-inch tube, or 39 turns of No. 20, or 33 turns of No. 22. If a 4-inch tube is used, either 29 turns of No. 18, 26 turns of No. 20, or 23 turns of No. 22. For use with a 10,000 meter intermediate wave, wind the 3-inch tube with 36 turns of No. 18, 34 turns of No. 20, or 30 turns of No. 22. If the tube has a diameter of 4 inches, it may be wound with 28 turns of No. 18, 23 turns of No. 20, or 21 turns of No. 22. These specifications will give a fairly wide range of variation to suit the particular size of coupler used.

From the pickup coil, the combination wave is passed on to the grid of the first detector tube. This, however, should not confuse the reader, who will probably wonder why it is necessary to use two detector tubes in the super-heterodyne circuit, but the reason for this is that the first detector is used in the transformation of the frequency while it is still above audibility, and a second detector is necessary to bring it down to audibility.

#### SPECIAL FOR JUNE

The Reinartz Radio Booklet, by Frank D. Pearne, fully illustrated, and RADIO AGE, for \$2.50. Price of booklet alone is 50c. Send check, currency or money order to RADIO AGE, 500 N. Dearborn Street, Chicago.

## CONSTRUCTION NOTES (S-30-10) WIRING AND CONNECTIONS

"A" BATTERY LINES. The following notes apply to connections made in the filament circuit such as connections to filament rheostats, to the "A" battery, sockets, etc. In making these connections care should be observed in having the correct polarity at all points.

- (1) Rheostat should be in negative line (-A) or (-F) for both detector and amplifier tubes.
- (2) While the polarity of the two posts marked (+F) and (-F) on the sockets is not of actual importance, yet the connections should be made to the posts with the proper polarity in order to have a systematic arrangement if nothing else.
- (3) Be sure that the rheostat has the proper resistance for the tube used. If the resistance is too high or too low, then the proper filament control will not be had.
- (4) At points where the (-A) and (-B) connections come on one post or on two directly connected binding posts, place the battery cutout switch in the (-A -B) lead rather than in the positive "A" (+A) line. If this is done, then both the "A" battery and "B" battery will be cut out when the switch is opened and the leakage of "B" battery current will thus be avoided when the line is idle.
- (5) Be sure that the rheostat binding posts are tight and are making good contact with the coil before making connections to the rheostats. Also make sure that the binding posts on the socket are tight and that the spring clips in the socket are not loose.
- (6) Adjust contact fingers of rheostats and potentiometers to the proper tension before wiring, and see that the contact finger makes proper contact with the coil in all positions. Adjustment of this part is difficult after the set is wired up.
- (7) As the rheostats and "A" battery lines are generally inaccessible on most sets after wiring, these parts should be mounted on the panel and completely wired before the other parts are installed.
- (8) Tube sockets should be mounted on rubber or felt cushions before wiring so that vibration will not cause the ringing bell like noises known as "microphonic noises." Particular care should be taken with dry cell tubes as these are generally strongly microphonic.
- (9) Use only heavy bus wire for the filament or "A" battery wiring since these lines carry comparatively heavy currents. No. 14 bare tinned copper bus wire is the smallest that should be used.
- (10) Wherever possible use solder lugs at the points of connection and solder the wires firmly to the lugs. Wires fastened only under binding screws are likely to loosen or corrode.
- (11) Wires should be well supported so that they cannot sag and come into contact with one another, thus forming short circuits.
- (12) Use spaghetti on the "A" battery wiring where considered necessary as a protection against short circuits, but leave it off on the lines which carry radio frequency currents as the spaghetti increases the distributed capacity.

## INDUCTANCES (F-2-1) INDUCTANCE AND FREQUENCY

WAVE LENGTH AND FREQUENCY. A radio wave travels forward at a velocity of 300,000,000 meters per second, or approximately 186,000 miles per second. This velocity of translation is approximately the same as for light waves. At the same time, the wave is subjected to a series of vibration so that the intensity of the wave is continually varying during this time. The rate of vibration or oscillation is determined by the characteristics of the circuit constants of the transmitting station and may range from 100 to 2,000,000 complete cycles per second in ordinary circuits. The rate of vibration or oscillation is known as the "frequency" of the wave.

In one second the wave travels a distance of 300,000,000 meters, and if the complete number of out and back oscillations (cycles) during this time are 300,000, then the distance between the centers of the peaks of the waves will be equal to the total distance divided by the number of double vibrations. This center to center distance between waves of like direction is called the "Wavelength" of the system and is totally dependent upon the frequency. Thus,

$$\text{WAVE LENGTH IN METERS} = \frac{300,000,000}{300,000} = 1,000 \text{ meters.}$$

In the form of a general rule for any frequency, this can be stated as follows:

$$\text{WAVE LENGTH IN METERS} = \frac{300,000,000}{\text{Cycles per Sec.}}$$

Or in the reverse sense we can obtain the frequency from the wave length by:

$$\text{CYCLES PER SECOND} = \frac{300,000,000}{\text{Wave Lgth.}}$$

It is profitable to note that the product of the wave length in meters by the frequency in cycles per second is always equal to 300,000,000. This fact gives us a check on our calculations.

KILOCYCLES. As the usual broadcasting wave lengths are in the nature of 500,000 to 1,000,000 cycles per second, the term "cycle" is too small to be handled conveniently, hence we frequently see the term "Kilocycle" used. A kilocycle = 1,000 cycles per second, hence the term 600 kilocycles means the same thing as 600,000 cycles per second.

WAVE LENGTH AND INDUCTANCE. The use of inductances, or combinations of inductances and condensers, gives us a means of bringing our receiving sets into resonance or into step with a transmitting station, or a means of rejecting certain stations which we do not care to hear. At the transmitting station, the use of inductances and condensers allows the station to send out waves of a given frequency.

Each inductance has a natural wave length or natural period of oscillation which may be increased or decreased by adding or subtracting turns of wire or by the use of condensers applied in parallel or in series with the inductances. The maximum flow of current through an inductance takes place when the inductance is so adjusted that it is in resonance or in step with the incoming radio impulses. This adjustment is commonly known as "tuning" and affords a means of receiving or rejecting stations operating at various wave lengths or frequencies.

In the calculation of inductances which are to cover a certain band of wave lengths, it is more convenient to use the frequency in terms of cycles per second than to use the wave length in meters. For this reason, when the frequency is given in meters of wave length, we must convert the wave length into terms of cycles per second by the above formula before proceeding with the calculation of the inductance.

# Radio Will Not Be Taxed

## Storm of Protest Defeats Senate Radio Tax

**R**ADIO is tax-free! The first attempt to place a federal tax on radio, which originated in the United States Senate with the proposal that a 10 per cent excise tax be levied on radio sets, parts and accessories, has been defeated after the greatest storm of public protest America has ever known.

The amateur radio "fan" was sponsored by virtually every force in the radio industry in his fight to make radio goods free from taxation of any kind. The United States Senate was literally flooded with literature and delegations protesting against the suggested "harnessing of American inventive genius."

### Starts In Senate

The proposed tax on radio was not contained in the revenue bill as it came from the House of Representatives, but was inserted by the Senate committee on finance. The principal clause was Section 700 of "Excise Taxes," which read:

SEC. 700. On and after the expiration of thirty days after enactment of this Act there shall be levied, assessed, collected and paid upon the following articles sold or leased by the manufacturer, producer or importer, a tax equivalent to the following percentage of the price for which so sold or leased.

10. Radio receiving sets, 10 per cent.

11. Parts and accessories for radio receiving sets, sold or leased to any person other than a manufacturer or producer of such sets, 10 per cent.

As soon as the proposal was made public, public sentiment rose immediately and set out to kill the radio clause in the revenue bill. Senator C. C. Dill championed the fans' cause in the Senate and arranged for the various petitioners to appear before the upper house of Congress to present their arguments.

The press, radio publications as well as newspapers, combined with the broadcasters and manufacturers to fight the radio tax. Members of the House of Representatives asserted they would do all in their power to kill the proposal in the event it was passed by the Senate.

### Public Sentiment Wins

Public opinion was so strong, however, that the radio excise tax died in the Senate itself, thus assuring radio from federal levy for at least two years.

The entire radio field stood solidly behind the amateur radio owner in his fight against the tax. At a meeting of metropolitan jobbers of radio products, held in New York, more than thirty jobbers pledged their support to the campaign.

A fund to help fight the tax was subscribed to liberally by the radio jobbers. The Radio Deals Inc., an organization with more than 100 members among the trade, went on record as opposed to the tax. The Radio Trade Association, the Radio Chamber of Commerce, the Radio Manufacturers of New Jersey, the Cleveland Radio Dealers' Association, the Pacific Radio Trade Association, the Atlanta Radio Trade Association and the Kentucky Radio Trade Association are but a few of the jobbers' and manufacturers' organizations who made their influence felt in Washington.

More than 50,000 circulars were distributed to dealers and jobbers by the Radio Trade Association of New York. A steady stream of telegrams from fans throughout the country pledged support to the campaign.

The Talking Machine and Radio Men, Inc., an organization of music producers and manufacturers, went on record against the tax. The National Association of Broadcasters helped to furnish the public and the newspapers with the fans' and broadcasters' reasons for opposing the tax.

### Dill Boosts Cause

Senator Dill, after furnishing the Senate finance committee with the public's petitions, introduced an amendment to the  
(Continued on page 40)

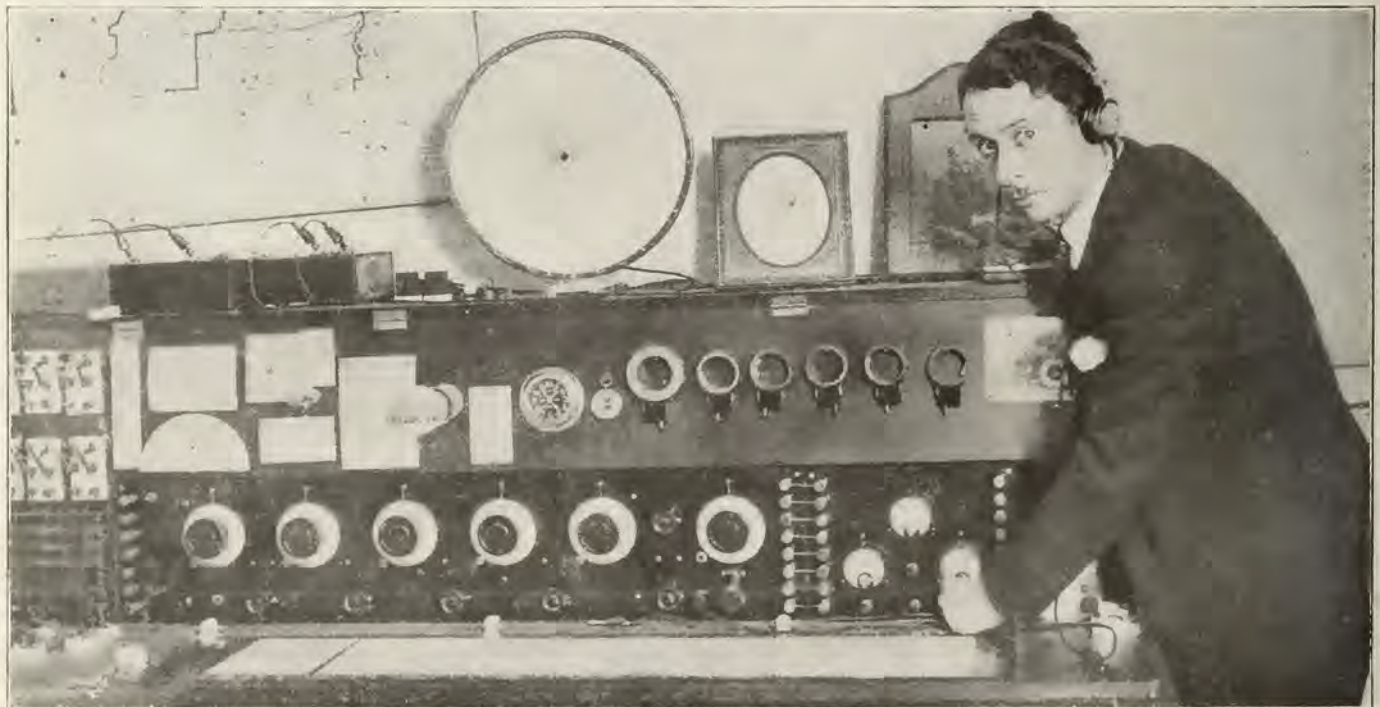

THE "LEVIATHAN OF RADIO"

Charles Caesar Ritz, of Forest Hills, Long Island, receives San Francisco and other California stations on the loud speaker of his four stage tuned radio frequency set with amazing clearness. Mr. Ritz, who is the son of Caesar Ritz, founder of the chain of Ritz-Carlton Hotels, builds all of his own equipment. The set shown in the photo is radically different in design and can be operated entirely as a four stage neutrodyne set or four staged tuned radio frequency set. This is quite an achievement, as it is considered virtually impossible to use more than two stages in a neutrodyne type receiver. Mr. Ritz has found that when he uses the set as straight tuned radio tuned frequency it is more selective and sensitive than when it is used as a neutrodyne. Eight tubes in all are used; four for radio frequency, one for detector and three for push-pull power amplifier.



### VACUUM TUBES (JJ-9-27) OPERATING CHARACTERISTICS

**AUDIO BIASING VOLTAGES.** In the following table are shown the proper negative biasing voltages for audio amplification for a given plate or "B" battery voltage. The biasing voltage is the voltage of the "C" battery in the grid circuit, and the values shown produce maximum amplification with a minimum of distortion for the various classes of tubes listed.

#### BIASING VOLTAGES FOR AUDIO AMPLIFICATION

TYPE OF TUBE	PLATE VOLTS	BIAS OR "C" VOLTS	NO. OF DRY CELLS
UV-201A, C-301A	40	0.5-0.75	1
"	45	0.7-0.9	1
"	50	1.0-1.5	1
"	60	1.5-2.0	1
"	67.5	2.0-3.0	1 to 2
"	75	3.0-4.0	2 to 3
"	80	4.0-4.5	3
"	90	4.5-5.0	3 to 4
"	100	5.0-6.0	3 to 4
"	112.5	6.0-7.5	4 to 5
"	120	6.0-9.0	4 to 6
UV-199, C-299	40	0.5-0.75	1
"	45	0.7-0.9	1
"	50	1.0-1.5	1
"	60	1.5-2.0	1
"	67.5	2.0-3.0	2
"	75	3.0-4.0	2 to 3
"	80	4.0-4.5	3
"	90	4.5-5.0	3 to 4
"	100	5.0-6.0	4
WD-11, WD-12, C-11, C-12	45	0.0-0.0	None
"	50	0.5-0.8	1
"	60	1.0-1.5	1
"	67.5	1.5-2.0	1 to 2
"	80	2.0-3.0	2
"	90	3.0	2
WE 216-A	45	1.0-1.5	1
"	67.5	3.0-3.5	2 to 3
"	90	4.5-6.0	3 to 4
"	112.5	6.0-7.5	4 to 5
"	150	12.0	8
WE-VT-2	90	4.5-6.0	3 to 4
"	150	12.0	8
"	200	22.5	15
"	350	40.0	28

### VACUUM TUBES (JJ-9-30) OPERATING CHARACTERISTICS

**BIASING AND PLATE CURRENT.** The plate current taken by the various tubes depends upon the plate voltage and the degree of bias placed on the grids, and whether this bias is of a positive or negative potential. A positive (+) bias is ordinarily necessary with a detector tube and causes a considerable current to flow, but in audio amplification circuits, super-regenerative circuits and a few other types, the use of a negative bias will greatly reduce the flow of plate current and will therefore greatly increase the life of the "B" battery.

In the following table, we have figures that apply to tubes operating under different degrees of bias. The flow of plate current is given in terms of "milliamperes" or thousandths of an ampere.

#### DETECTOR TUBE PLATE CURRENT

TUBE NAME	"B" VOLTS (PLATE)	"C" VOLTS (BIAS)	PLATE CURRENT MILLIAMPERES	FILAMENT CURRENT (AMPERES)
UV-199	22.5	+1	0.60	0.06
C-299	45	+1	1.65	0.06
UV-200	22.5	+1	0.75	1.00
C-300	22.5	+1	0.75	1.00
UV-201	22.5	+1	0.60	1.00
C-301	45	+1	1.80	1.00
UV-201A	22.5	+1	0.50	0.25
C-301A	45	+1	2.00	0.25
WD-11	22.5	+1	0.70	0.25
WD-12	45	+1	1.75	0.25

#### AUDIO AMPLIFIER PLATE CURRENT

UV-199	45.0	0	1.40
C-299	67.5	0	2.40
"	67.5	-3	1.80
"	90.0	0	4.00
"	90.0	-4.5	2.25
UV-201	45.0	0.0	1.50
C-301	67.5	0.0	2.50
"	67.5	-3.0	1.90
"	90.0	0.0	3.90
"	90.0	-4.5	2.10
UV-201A	45.0	0.0	1.50
C-301A	45.0	-1.5	1.10
"	67.5	0.0	3.50
"	67.5	-3.0	1.90
"	90.0	0.0	6.00
"	90.0	-4.5	2.00
WD-11	45.0	0.0	1.50
WD-12	45.0	-1.5	1.10
"	67.5	0.0	2.50
"	67.5	-3.0	1.60
"	90.0	0.0	4.50
"	90.0	-4.5	2.50
216-A	120.0	0.0	13.80
"	120.0	-9.0	7.50

The effect of a negative bias on the UV-201A or C-301A is very pronounced, as with a bias of -4.5 volts, the tube only takes one-third the plate current taken with zero bias.

(Continued from page 38)

revenue bill cancelling the 10 per cent tax. This amendment prevented a summary approval by the Senate and caused the radio provision to be subjected to open debate.

A nation-wide appeal to amateurs interested in radio to join the fight on the tax was sent out by the American Radio Relay League through Hiram Percy Maxim, president of the organization.

The American Radio Relay League has a membership of 16,000 amateurs throughout the country. These amateurs own low power transmission and receiving sets which they use to pick up and relay non-commercial messages.

"A proposal to tax radio is an effort to levy a financial burden on the amateur inventive genius of this country," Mr. Maxim asserted. "Radio owes much of its development to the research work that has been done by the young men of the nation. Radio has probably done more than any other agency for keeping boys at home. It has stimulated imagination, thought and scientific effort.

**A Needless Tax**

"Why should we needlessly cripple it? The Radio Relay League does not believe that any such service should be taxed without need. The educational opportunities of radio should be stimulated instead of handicapped. We don't tax schools and colleges in this fashion, so why should we tax this newest and greatest of educational agencies?"

William P. Davis, chairman of the

Emergency Radio Tax Committee of New York, reported that "immediate, spontaneous hostility to the public has been expressed by letters, telegrams and editorials throughout the country. There has been no favorable expression of opinion regarding the radio tax. The only argument advanced for the tax is that the money must be raised somehow.

"Against this, criticism is expressed everywhere against imposing this tax on an industry just struggling to its feet, with an enormous amount of development and standardization confronting it and no solution yet offered for the great problem of broadcasting.

**Tax Would Raise Prices**

"Such a tax would have an adverse effect on the tendency to improve product and reduce prices; a most deplorable condition, especially because the manufacturers could not absorb the taxes, which would then have to be passed on to the consumer with all the intermediate increases inevitable in such a process.

"There is also a general impression that by resisting this new nuisance tax the people will hasten the final elimination of existing nuisance taxes. Radio has been developed and perfected largely by the inventions of amateurs.

"By placing burdens on these amateurs, the government will actually be taxing American inventive genius."

Senator William S. McKinley from Illinois opposed the tax in a statement to the Radio Trade Association:

"I am opposed to the taxation of the

radio business," he said. I consider radio the greatest discovery of the age and one which is bringing pleasure to untold millions of people."

**World Metric Standards**

Adoption of metric units of weights and measures in merchandising will be a timely topic of discussion before the great convention of the Chamber of Commerce of the United States, to be held at Cleveland in May. On May 5th the metric issue will be prominent, the national council being called upon to advise whether the pending Metric Referendum shall be submitted to nationwide vote of American business organizations.

A year of study and conference was devoted to world standardization by the Metric Committee of the Chamber of Commerce of the United States, and the report of this group will be the basis of the vote. Already the national council is on record in favor of sympathetic consideration of the metric advance, and it is believed that the Referendum will be called forthwith.

**Wendell Hall on Mardi Gras From WLS**

Wendell Hall, the traveling radio troubadour, and the Cambridge Sisters, the divine trio of harmony, featured the Herald and Examiner's Midnight Mardi Gras from WLS recently. Hall, the famous "red-headed musicmaker," sang, among others, his own "Dear Heart of Mine," "Shattered Dreams" and "If I Only Knew."



**BUILD THIS FAMOUS 5 TUBE KIT**

Complete Quick Assembly Outfit of Synchronized Receiving Set to Reach From Coast to Coast With Amazing Selectivity and Clarity

WRITTEN Money-Back Guarantee. This is the amazing set selling by thousands all over America. No radio knowledge needed, no skill with tools, no experience. Every one instantly understands our extra complete instructions and simple, clear blueprint diagram. Just 2 or 3 hours fascinating fun builds your set. You can't go wrong. You get the big broadcasting stations. Extraordinary long distance from Coast to Coast is easy. Only the best in this set—ALL genuine STANDARD NEUTRODYNE parts LICENSED under the original HAZELTINE patents and guaranteed to give perfect results and satisfaction. Also all parts are MATCHED for beautiful appearance. The front is the hand-somest ever made, reproducing fine mahogany, with every marking engraved in GOLD. A magnificent ornament. A perfect, highest grade, efficient, powerful instrument that you cannot duplicate for THREE TIMES THE PRICE.

**WHAT THIS GENUINE STANDARD SET CONSISTS OF—**

- 1 Drilled Radiom Mahogany Panel, like mahogany, engraved in gold; 3 4-inch Radiom Mahogany Dials, gold engraved; 2 gold-plated Jacks; 3 genuine Hazeltine Neutrolformers mounted on the famous Comco Bakelite End Condensers (positively the only Neutrodyne Kit including these famous Comco Condensers); 2 Hazeltine Neutrodons; 5 Bakelite Sockets; 1 6-ohm Rheostat and 1 30-ohm Rheostat with gold-plated knobs to match panel; 2 genuine K Mark completely shielded Audio Transformers; 1 Baseboard; 30 feet Tinned Bus-Bar; 1 .00025 Freshman Grid Condenser; 1 Tubular Glass Grid Leak; 1 Set Engraved Binding Posts; 1 .002 Micon Condenser; 1 .006 Micon Condenser; Exact Size Special Panel; Instructions and Blue Print; all packed in large handsome partitioned box, \$34.49 complete.

**ACCESSORIES TO PUT SET IN OPERATION**

Everything needed to operate set after building—5 Tested Tubes (Type 201A), \$19.50; 2 45-volt extra large Variable "H" Batteries for Neutrodyne, \$6.50; 1 60-ampere Hour Storage Battery (guaranteed 2 years), \$11.25; 1 pair 3,000-ohm Phones, \$3.75; Double Plug, 90c; 1 Antenna Equipment, \$1.50; COMPLETE OUTFIT, \$43.40. (Accessories also sold separately.) If you order Building Outfit and Operating Outfit both together we will include fine Mahogany Finish.

**CABINET FREE**

SEND NO MONEY. We ship C. O. D. Pay your postman. Then build and enjoy your set under our WRITTEN Money-Back Guarantee sent with equipment. We acknowledge all orders by return mail. Ship same or following day. We answer every letter we get on same day. The Radio Shack are the largest Radio Dealers in America. No inferior goods. Only the best and most reliable. You buy in safety. Send your C. O. D. order today. This present low price cannot continue. Act NOW. Circular FREE, with Broadcast List and Map.

**THE RADIO SHACK** Dept. RA6, 55 Vesey Street, New York, N. Y.

GENUINE, STANDARD, SYNCHRONIZED LICENSED HAZELTINE

WRITTEN MONEY-BACK GUARANTEE

SEND NO MONEY WE SHIP C. O. D.

**\$34<sup>49</sup>**

**Read These Letters From Enthusiastic Fans**



**LOOK AT THIS MAP SENT IN**

"From Clawson, Michigan, I get from Coast to Coast on my horn, including HONOLULU, HAWAII, on the night of March 21, at 2:05 A. M." —Dale Jenkins, Clawson, Mich.

"I congratulate you on giving the radio fans these wonderful bargains." —A. J. Toll, 742 Nelson St., London, Ont., Can.

"I would have had to pay three times your price out here for the same parts I bought so low from you." —Stephen Vandrey, 520 16th Ave. N., Nampa, Idaho.

"Enclosed find map I made for you in appreciation of your De Luxe Neutrodyne. This map shows results I obtained on Thursday evening, March 27, 1924—a total of 35 stations from Canada to Texas and Florida, and from Massachusetts to California, all in 5 hours—as far north as Toronto, and south to Miami and Dallas. To date I have listened to a grand total of 57 stations—8 in New York; 4 in Newark; 3 in Chicago and Philadelphia; 2 in Pittsburgh, Davenport, Hastings, Kansas City, Providence, Omaha, Cincinnati and Los Angeles; and 1 each in Columbus, Toronto, Washington, Zion City, Plainfield, Scheuectady, Rochester, Topeka, Jackson, Minneapolis, Lockport, Boston, Dallas, Jefferson City, Urlana, Mattapoisett, Tarrytown, Elgin, Oak Park, Cleveland, Atlanta, Oakland and Miami." —J. H. Roberts, 2036 Woolworth Bldg., New York City. (These are from hundreds of letters constantly coming in with high praise.)



Always Mention RADIO AGE When Writing to Advertisers

# A Chat With the Big Family

**R**ADIO AGE has undergone a process of enlargement and extensive changes have been made in all departments. The magazine has moved into more roomy offices, the second move which has been forced by increasing business within the year.

The radio public has been kind enough to put its stamp of approval on our periodical and as a result the task of making good our slogan "Service to Readers First" has become more complicated and difficult. Correspondence is enormous and this chat with readers is for the purpose of suggesting ways and means of more effective cooperation between reader and publisher.

We want to discuss details which, when taken individually, are trifles, but which become vastly important in the maintenance of a smoothly functioning, extensive service system. RADIO AGE has a technical service department, the value of which is known only to those who use it. In order to make that department more useful we are asking readers to keep in mind the following details:

### Remittances

Occasionally, one of our readers will find it necessary to place an order for a back number; a copy of the Reinartz Book; or perhaps desires a copy of the new book just off the press, the *RADIO AGE ANNUAL*. This involves the handling of money, stamps or currency or other form of exchange, as the case may be.

In remitting by check, stamps or currency, you run little or no risk in sending the order by first class mail—but don't you think that it would be more sure if you took the time to register your letter? In event that we fail to receive your letter, the matter could so much more easily be cleared up if the letter were properly safeguarded.

Copies of the *RADIO AGE ANNUAL* are sent to purchasers by parcel post. To assure our patrons of the promptest delivery, and to further insure their safe delivery, they are listed at the Post Office. In event that any of our patrons fail to receive their orders, we suggest that they inform us promptly, in order that investigation may be made, and the trouble located without undue delay.

### Subscribers

Occasionally we are informed by our subscribers that they fail to receive their magazines, and we would like to advise that they notify the Subscription Service Department immediately, in order that the trouble may be located, and the correction be made. Should subscribers change address or move, we earnestly request that they inform us. Failure to do so leaves a magazine without a recipient.

Incidentally, we wish to tell our readers that we cannot assume the responsibility for the loss of money in the mails or in transit, nor can we assume the loss of any orders shipped, when our records show that the order has been filled and

sent out. We would advise our subscribers to be careful about permitting their mail to lie in hallways or on porches, as it has often come to our notice that magazines have been appropriated by people other than to whom they are directed, after delivery by the mail carriers.

Another thing which saves time and gets your order out is to list all your orders and subscriptions on a separate sheet other than that of your pickups, records or questions.

### Technical Questions

Whenever your letter contains a request for technical information, it is a good and effective plan to list your questions on a separate sheet, which can be easily turned over to the service department for attention without first waiting for your order to be listed, the subscription entered and your instructions noted.

Subscribers are requested to enclose a stamped, addressed envelope if they desire an answer. No answers will be mailed unless this detail is observed.

Address your questions with regard to technical difficulties to RADIO AGE, Inc., Technical Office, 500 North Dearborn Street, Chicago, Illinois, if you desire the promptest of service.

In closing this little get-together talk, we wish to advise the usual, old, and stereotyped phrase, "Put the return address on all your correspondence." Write legibly, and don't take chances in sending coins in plain envelopes.

### To Avoid Radiation

The fact that many receiving sets are so constructed that they radiate an oscillating wave from the aerial has been a source of constant interference which is growing daily. As a result of an article on this subject published a short time ago, many letters have been received asking how this may be prevented, which shows conclusively that some of the fans, at least, take this matter seriously and want to do their part in the elimination of this nuisance.

In the case of a regenerative set one can do much in the way of clearing up the air by learning to tune properly. Any set in which the plate is connected to the aerial will be one of the worst offenders. In the operation of this kind of a set some other method besides careful tuning

will be necessary. The radiating effect may be partially reduced by connecting a potentiometer in the aerial circuit. This is done by connecting the middle arm, or lever, of the potentiometer to the aerial binding post on the set, and either one of the other terminals to the aerial.

This may sound peculiar, as it increases the resistance of the aerial circuit, but, curiously enough, it does not seem to interfere with the reception.

### RADIO AGE and RADIO AGE ANNUAL

A year's subscription to this magazine and a copy of the famous handbook of drawings and instructions on how to make standard receiving sets. 112 pages.

**All for \$3.00**

Send today by check, registered mail or money order to

**RADIO AGE, Inc.**  
500 N. Dearborn St. Chicago, Ill.

### BREMER - TULLY

**\$500 Nameless Circuit**

B T 3 Circuit R. F. Transformers and the \$500 Nameless Circuit have solved the problem of Radio Frequency Amplification—Nothing to equal it for strength of signals. Orders are far in excess of production. Place your order with your dealer at once for future delivery. Illustrated folder of Diagrams, etc., on request.

### BREMER - TULLY

**Manufacturing Company**  
532 S. Canal St. Chicago Ill.

### 378 DX STATIONS

DX Fans. If you have not logged 300 stations in past six months you need a Kennedy Three Circuit Tuner. The Kennedy Tuner logged 378 stations from September 15th to March 15th, including 2LO, London; 5WA, Cardiff, Wales; CFCN, Calgary, Alberta, Canada; KGW, Portland, Oregon; KFI and KHJ, Los Angeles, California; KPO, San Francisco, California; KGO and KLX, Oakland, California.

**Kennedy Tuner Takes the Place of**  
3 Honeycomb Coils at \$1.40.....\$ 4.20  
1 Honeycomb Coil Mounting..... 5.09  
1 23-Plate Vernier Condenser..... 5.09

**INCLUDING GLOBE \$5.00** \$14.20

**TROTTER DIAGRAM**

**T. J. KENNEDY**

**Radio Globe Trotter**

470 W. 159th Street, New York, N. Y.  
**GUARANTEE:** If not satisfied after 30 days will cheerfully return your money.



No soldering outfit is complete without a good brush for applying the soldering acid. Every radio dealer should carry these in stock. Put up, 1 gross to the package. Send for prices and samples.

**The Specialty Mfg. Company**  
11400 Madison Ave., Cleveland, Ohio

# Trouble The Shooter

M. O. B., San Francisco, Cal.

**Question:** I have had quite an argument with my landlord with respect to the danger of lightning striking an antenna, and I would like to have your opinion on the subject. He says that it is very dangerous, that it attracts bolts toward the aerial wire, and consequently exposes one to the dangers of an electrical discharge of this nature. What is your opinion on the subject?

**Answer:** Funny as it may seem, some people persist in believing that radio antennas "draw" lightning during an electrical storm, and I want to say right now that this opinion is all wrong and should be discouraged. In the first place, a bolt has about as much chance of attacking your antenna system, as it has of striking your wife's clothes line.

Tell your friend that if your antenna is properly protected by an approved lightning arrester, which is properly grounded, the system becomes a protector of property instead of a hazard. However, a well constructed non-grounded antenna has the properties of accumulating a strong charge of electricity during a storm of any great electrical violence, and if the antenna is not grounded properly, this charge can jump a good distance from the lead-in end of the system into various grounded objects. If the object happens to be inflammable, it can cause a fire, but this is about the only danger which exists.

Don't fail to make your queries and letters conform with the rules published in the May, 1924, Troubleshooter section. There is no excuse for not complying with rules such as were found necessary to assure all our readers an equal chance of this service.

We have a number of questions on hand at present that have not been answered because their writers did not observe the rules as they were specified. Due to the great number of questions we receive, this has been found necessary, in order that justice may be done to all of them.

If you don't know what we are referring to, read the notice published on page 42, Troubleshooter section of the May, 1924, issue.

Technical Editor.

Some time ago, I carried on a test to see how much of this theory was true, and leaving my experimental antenna, which happens to be very well insulated and ungrounded, I inserted a small air gap, one side of which was connected to a good ground.

The gap between the electrodes was about one-half inch, and during the storm, heavy sparks jumped the gap, surprising everyone who saw the display. Another time, using an antenna during dry weather when a lot of static was in the air, I found that my antenna accumulated strong enough charges to jump the plates of a variable condenser which I had connected in the antenna lead of the receiver. It is herein that the danger lies, and not in the actual striking of the bolt.

R. N., New York City

**Question:** Kindly give a diagram of the Low Loss Receiver described in your March number in connection with a two-stage amplifier. I have constructed this set, and find it does everything you say it does. Tuning is very sharp, and stations come in with great intensity. The set is a very convincing argument for good condensers, and has taught me a good lesson about choice of apparatus.

**Answer:** We are printing in *Figure 1* a diagram of the circuit you desire. Reports on this receiver indicate that it is a very popular one among broadcast listeners, due to the fact that it is easy to construct, easy to operate, and tunes very sharply. C batteries should be inserted in the leads marked X if a high plate voltage is used. This will conserve your B battery by keeping the drain on that part of the set as low as possible.

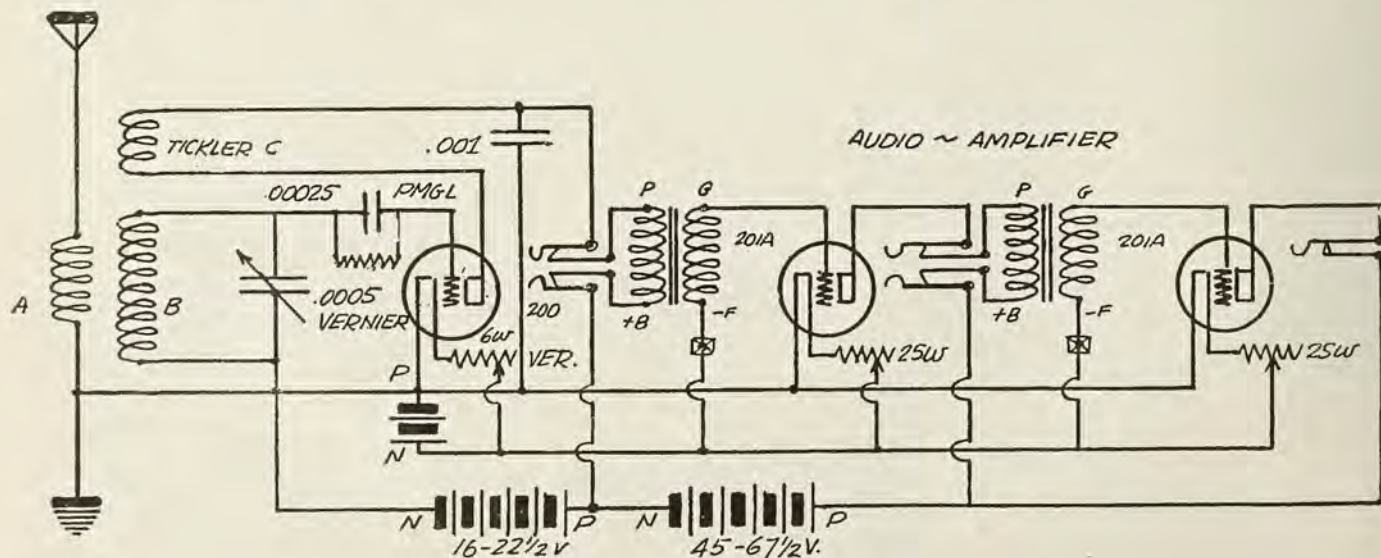

Figure 1. A diagram of the Low Loss receiver showing the addition of two stages of audio frequency amplification. C batteries can be added at the points marked X.

# HOWARD PARTS

No. 1001 Rheostat, \$1.10  
 No. 1003 Potentiometer, \$1.50  
 No. 1002 Micrometer, \$1.50  
 At All Dealers.



## PREMIER

**Audio HEGEHOG**  
 Frequency Transformer  
 One-half actual size \$3.50  
 Best for Portable Sets  
 About the size of an English Walnut. Saves space; light weight; mounts anywhere; unsurpassed in performance. Ratio 1 to 3, 1 to 4, 1 to 5, \$3.50. 1 to 10, \$4.50. Ask your dealer for this "Little Wonder"  
**Premier Electric Company**  
 3803 Ravenswood Avenue CHICAGO

**\$1.00 STARITE \$1.00**  
 THE BEST CRYSTAL IN THE WORLD.  
 Unconditionally Guaranteed.  
 PRICE, \$1.00 and worth it.

**STAR CRYSTAL CO.**  
 53 W. Jackson Blvd., Chicago, Ill.  
 Factory, Detroit, Mich.

### CLASSIFIED ADVERTISEMENTS

Six cents per word per insertion, in advance. Name and address must be counted. Each initial counts as one word. Copy must be received by the 15th of month for succeeding month's issue.

#### RADIO CIRCUITS

If your Neutrodyne won't "Neut" o. k., send 10c for Details of Kladag Coast to Coast circuit, bill of materials, etc., to change over your Neut into a set that will bring them all in from Mexico City to Tunucu, Cuba, on a loud speaker. Or send \$5.00 for all extra parts, blue print, etc., you need to do this. Stamps accepted. Radio list for stamp. Super Heterodyne specifications, 10c. Kladag Radio Laboratories, Kent, Ohio.

#### RADIO EQUIPMENT.

Harkness circuit two tubes take place of four or five; Detector 2 R. F., 2 A. F. Complete, genuine parts including set of Flex-o-formers, Rheinholt detector and 201-A type tubes, \$23.50. Range, 1,000 to 1,500 miles on loud speaker. New Catalog 64 on request. Royal Manufacturing Co., 206 Broadway, Dept. 19, New York.

#### TRANSMITTING SET

15-20% DISCOUNT ON ALL STANDARD RECEIVERS. Fried-Elsemann Neutrodyne, \$125.00; New Radiolas, etc. Thomas Radio Co., 111 Dex St., Muncie, Ind.

#### RADIO BATTERIES

Super Radio A and B Circuit Batteries, which bring in long distance reception. Sold for cash or on payment plan. Write for prices and details. Radio Battery Corporation, 501-B Industrial Bank Bldg., Flint, Mich.

#### MISCELLANEOUS

158 GENUINE Foreign Stamps. Mexico War Issues. Venezuela, Salvador and India Service. Guatemala, China, etc., only 5c. Finest approval sheets, 50 to 60%. Agents Wanted. Big 72-p. Lists Free. We Buy Stamps. Established 20 Years. Hussman Stamp Co., Dept. 152, St. Louis, Mo.

R. T. C., Chicago, Ill.

*Question:* I have a single circuit receiver, which I am told oscillates and sends out carrier waves into the air which spoil my neighbors' reception. I am told that it does this only when the set is in the oscillating stage, and when it is doing so, I am not getting maximum efficiency out of it. Is there any instrument that I could put in the circuit that would tell me when the set is transmitting energy? How can I stop it?

*Answer:* It is pretty hard for the average fan to tell when his set is in the oscillating condition except by noting the noises which the set emits while tuning. When you tune across the wave of a broadcasting station, and the set gives a whistle which varies as you move any of the knobs, it is an infallible sign that the set is oscillating and transmitting energy.

Another test possible is to touch the set in any part in the grid circuit or antenna circuit. If you have taps in the antenna circuit, you can try lifting the switch lever. If the set is oscillating, a pronounced "thud" or "thuop" will be heard in the phones. If not, a light click or scratch will be heard.

Another sign of an oscillating receiver is a slight whistle or whine with the signal when reception is carried on. You can put a milliammeter of about 0 to 25 milliamps maximum in the plate or tickler circuit and watch the meter pointer as it travels across the face of the scale. As the set bursts into oscillation, the meter usually gives a decided swing toward maximum, indicating resonance. This is nearly always a sign that the set is oscillating.

The best results are obtained when one tunes just below the regenerating point, as the signal will then come in without the customary squeals and whistles. To accomplish this, reduce the filament current, and the tickler coupling, and if it is still difficult to control, adjust your grid leak until it does so. It is often necessary to use a smaller grid condenser to accomplish this purpose.

However, under no circumstances should you let your set radiate strongly, as the use of aperiodic coupling will reduce this nuisance to a minimum.

A. M. B., Des Moines, Iowa

*Question:* I have read with considerable interest the comment on honeycomb receivers, and would like very much to have you print a diagram of a receiver using this circuit. I note in your magazine of a month or so ago that you mention the results obtained by T. J. Kennedy, and would like very much to have a diagram of a receiver of the type used by him.

*Answer:* I am printing in Figure 2 a copy of the diagram used by Mr. Kennedy in his record-breaking receptions. The antenna series condenser (which by the way can be placed in either antenna or ground leads) should be a good 23-plate vernier type and is not very critical in tuning. The other secondary condenser across the honeycomb is the tuning unit

## 3-IN-1 UNIT Audio Amplifier

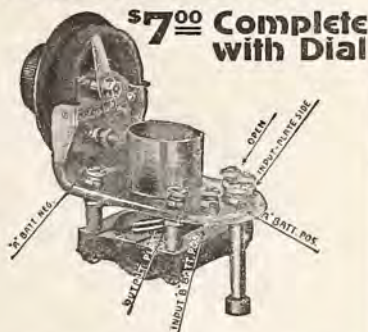

This highly efficient unit consists of RHEO-STAT, SOCKET and TRANSFORMER adapted for any set where amplification is desired. Will amplify your CRYSTAL SET for loud speaker use.

Due to its compactness it is ideal for use in making a portable set. Every 3-in-1 unit fully tested and guaranteed.

Specially wired unit for reflex work.  
 WELTY'S Loud Speaker.....\$25.00  
 WELTY'S Loud Speaker Unit..... 9.00

**STRICTLY HIGH GRADE.**  
 Mail orders promptly filled.

**WILLIAM A. WELTY & CO.**  
 36 So. State St. Chicago, Ill.  
 Dealers Correspondence Invited.

*The Traffic Cop of the Air*

He arranges in orderly fashion the mass and jumble of Broadcasting Stations that are seeking entrance to your set and brings them in, one at a time, so you can enjoy them! Never reduces, but nearly always increases volume. Add a Ferbend Wave Trap to your set and "Police" your reception. Regulate the Traffic!

Guaranteed to tune out any interfering station. The price is \$3.50. Shipment is made parcel post C. O. D. plus a few cents postage. If you prefer, send cash in full with order and we will ship postage prepaid. Send us your order today.

**FARBEND Wave Trap**  
 FERBEND ELECTRIC COMPANY  
 16 E. South Water St., Chicago, Ill.

**RADIO CABINETS  
 RADIO SETS  
 EQUIPPED PANELS**  
 Ask Us About PHUSIFORMERS  
 LAKESIDE SUPPLY CO., Dept. R  
 73 West Van Buren Street  
 Telephone, Harrison 3840 CHICAGO, ILL.

**NEXT TIME INSIST ON "COMET" "B" BATTERIES**

At all good radio stores or write

**ELECTRICAL MFG. AGENCY**  
 25 N. Dearborn St., Chicago, Ill.

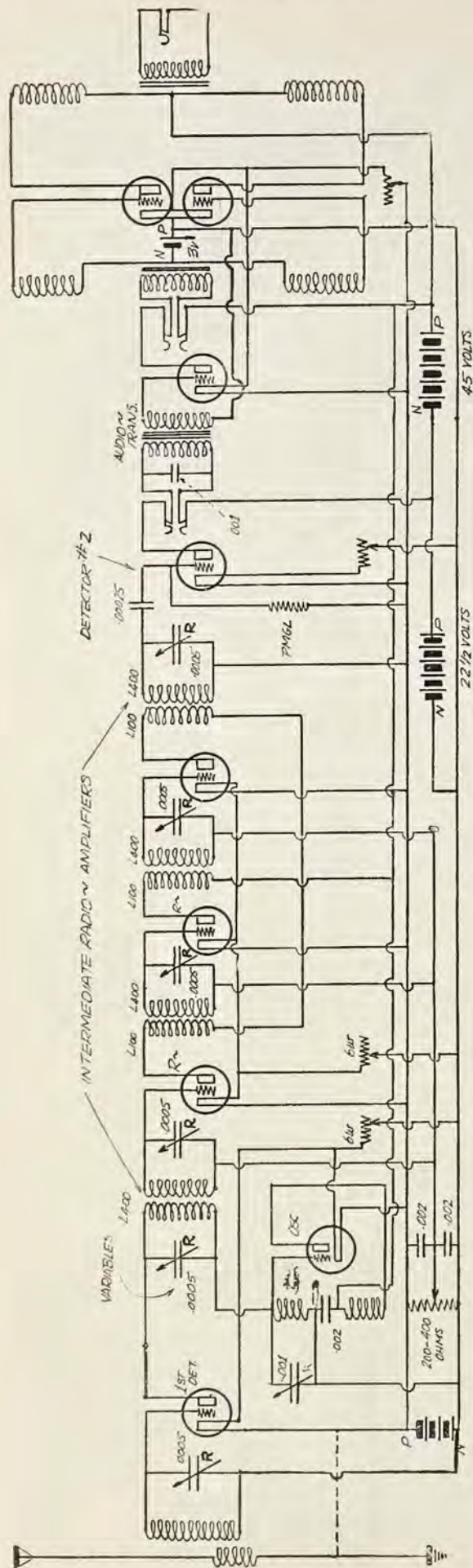

Figure 3. Another diagram of the McCullah Super-Heterodyne receiver showing several improvements. While only nine tubes are shown, another stage of radio can be added in the usual manner.

The improvements made incorporate a variable condenser across the primary of the longwave coils so that any intermediate wave length can be used on the radio frequency stages as are within the range of the coils. The oscillator condenser is connected across the grid coil of 27 turns instead of across both plate and grid inductances. The first detector is also changed, as it has no plate battery potential. The rotary plates of the variable condensers should be connected to the filament circuit as indicated to offset any hand capacity which may develop. Four rheostats are used, the first controlling the frequency changer and oscillator; the second, the intermediate stages; the third, the detector and the last the audio frequency unit.

The circuit is often improved when the positive filament is grounded as indicated by the dotted line. A pencil mark grid leak, as described in this issue, is used on the second detector, as shown next to the legend PMGL.

and should be of the very highest grade for maximum results.

The detector rheostat should be of the vernier type to permit close adjustment of the filament current; a factor of great importance in any receiver. Mr. Kennedy uses fixed condensers of .00025 MF capacity with a grid leak shunted across the G and F posts of the audio transformers to help eliminate noises in the set, an idea which is very practical. No jacks are used in the detector or first stage circuits, due to the fact that they contribute to noises in the receiver.

M. T. P., Birmingham, Ala.

*Question:* I have a three circuit receiver, and would appreciate a few instructions as to the method of tuning a receiver of this kind. I find that it tunes very closely, but I have much trouble in deciding which control I should manipulate to get the best results. Could you give me a few pointers?

*Answer:* The matter of tuning any receiver, as I have said before, is a matter of practice, and the familiarization of one's ears to the various noises of the set. However, I will outline briefly the procedure that is usually followed with a standard three circuit tuner using two variometers and a coupler. Set the grid and plate variometers at zero. Vary the secondary (rotor) of the variocoupler until a signal is heard. This signal should be tuned in to maximum intensity.

Next, vary the grid variometer until the signal is further increased in strength. The plate variometer is then varied until a point is reached where the familiar "thud" or "thump" accompanying regeneration is heard. The filament can then be turned back until the signal comes in clearest, or the plate variometer can be brought back (or both) until a point just below oscillation is reached, where the signal will be loudest. It is customary to set the secondary of the coupler first, and then vary the grid and plate variometers together until the best effect is reached. If difficulty is had in finding this point, the rheostat is resorted to, and the filament should be decreased or increased until the proper value is found. I am assuming, of course, that the grid leak and other values such as the plate battery are at maximum effectiveness. If interference is encountered, the secondary of the coupler should be turned to decrease the coupling between that coil and the primary.

A. S. M., Toronto, Ont., Canada

*Question:* I have constructed one of your super-heterodyne receivers as was described by your Mr. McCullah in the April, 1924, issue. While the set functions, I find that its range is rather limited, and I would like very much to know if you could suggest anything to improve the range.

*Answer:* In Figure 3, I am printing a diagram of the super-heterodyne receiver of the type designed by Mr. McCullah with several changes thereon.

The fixed condenser across the primary of the LWC (long wave coils) is sub-

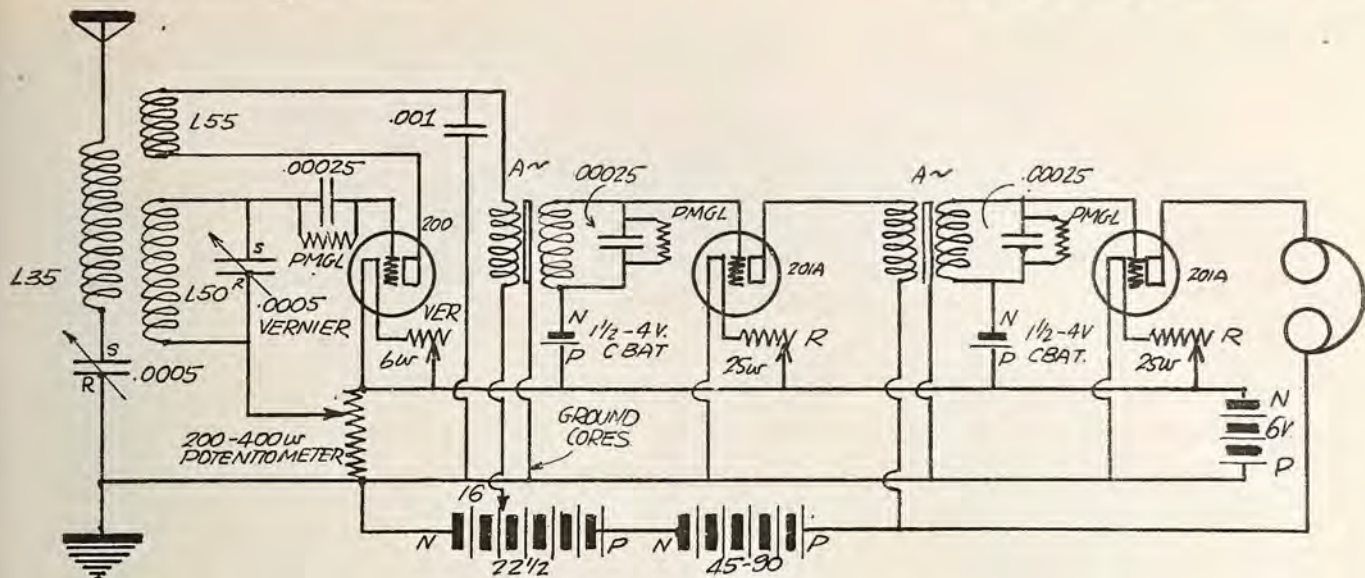

Figure 2. A diagram of the receiver used by T. J. Kennedy in his record breaking receptions. The secondaries of the audio transformers are shunted by a .00025 MF condenser and a variable pencil mark grid leak.

stituted with a .0005 MF variable, which permits the use of different intermediate waves for amplification. With some minor changes in the plate circuit of the first detector and grid circuit of the oscillator, the circuit is practically the same. For lack of space only 9 tubes are shown, the original circuit using 10. The omitted tube is the radio frequency amplifier which is added in the ordinary manner.

**Scotch Loop Gets WGY**

James Mackintosh of Inverness, Scotland, found WGY signals coming in so strong that he decided to try a frame aerial consisting of four turns of bell wire wound on a square frame with four feet sides. "Surprising were the results," reports Mr. Mackintosh, "the music from WGY was distinctly audible and the speech just defined enough to enable the call sign to be obtained."

**American Sets Wanted**

It is only natural that for American broadcast reception American-made apparatus is sought abroad, and nearly every week requests for radio apparatus, data and catalogues are received by the Department of Commerce. Many overseas seek to become agents of American manufacturing firms and the Department is forced to keep a list of such requests for reference. Just now Italy is seeking receiving sets suitable for reception on wave lengths from 400 to 600 and 400 to 4,000 meters, and ranges from 10 to 2,000 miles. Calls have also been received recently from Brazil, Portugal, Sweden, New Zealand and Australia for apparatus and batteries. Some countries are already jealous of American sets and have prohibited its importation or imposed high tariffs to protect home-made sets.

Radio to Prevent Forest Fires  
Messages by Secretary of Agriculture

Wallace and Governor Gifford Pinchot of Pennsylvania were broadcast from thirty radio stations during Forest Protection Week, April 21-27, as a means to spread the doctrine of forest fire prevention. Several of the messages were broadcast personally by Governor Pinchot and Secretary Wallace from stations in Harrisburg, Pa., and Washington, D. C. In addition to their messages, talks on forest fires were made over radio by forestry officials of many states and by members of the Forest Service. Early reports indicate that the radio appeal for forest protection was so effective it will probably be made a regular government policy.

**A-1 CRYSTALS GET DISTANCE**

*Ideal for Reflex*  
"Have received 30 stations on my Crystal Set using A-1 Crystals, including KGO, Oakland, California, 1,525 miles distant."  
Gilbert Beck, Texas.  
**A-1 CRYSTALS**  
*Guaranteed Tested*  
Sent Postpaid 50c Each  
Sixty Cents if sent C. O. D.  
**California Radio Minerals**  
HARRY GRANT, JR.  
904 Oak Grove Ave.  
**BURLINGAME CALIFORNIA**

**ARROW BATTERY SLASHES Prices**

**Prices Smashed!**  
Quality Not Sacrificed  
To CONSUMERS ONLY  
Here is real battery quality, guaranteed to you, at prices that will astound the entire battery-buying public. Order direct from factory. Put the Dealer's Profit in your own pocket. You actually save much more than half, and so that you can be convinced of true quality and performance, we give a **Written Two-Year Guarantee**

- Here is your protection! Noneed to take a chance. Our battery is right—and the price is the lowest ever made. Convince yourself. Read the prices!
- Special 2-Volt Radio Storage Battery, \$3.75
- Special 4-Volt Radio Storage Battery, 6.00
- 6-Volt, 60 Amp. Radio Storage Battery, 7.00
- 6-Volt, 80 Amp. Radio Storage Battery, 8.00
- 6-Volt, 100 Amp. Radio Storage Battery, 9.50
- 6-Volt, 120 Amp. Radio Storage Battery, 11.50
- 6-Volt, 140 Amp. Radio Storage Battery, 13.00

We ask for no deposit. Simply send name and address and style wanted. Battery will be shipped the day we receive your order Express C. O. D., subject to your examination on arrival. Our guarantee accompanies each battery. We allow 5% discount for cash in full with order. You cannot lose! Act quick. Send your order today—NOW.

**Arrow Battery Co.**  
1421 South Wabash Ave.  
Dept. 11 Chicago, Ill.



**LEARN RADIO**

Become a big-pay man in the greatest industry of all time. Quickly, easily and right at home, you can fit yourself for highest salary positions, or you can cash in on your spare time. The call is urgent for mechanics, operators, designers, inspectors. Unlimited, fascinating opportunities on land or sea.  
**I WILL TRAIN YOU AT HOME TO BE A RADIO EXPERT**  
Under my practical, easy to understand, instruction—you qualify in an amazingly short time. No previous experience is necessary. Every branch of radio becomes an open book to you. You learn how to design, construct, operate, repair, maintain and sell all forms of Radio apparatus. My methods are the latest and most modern in existence.  
**FREE** Wonderful home construction tube receiving set of the latest design. **Write Today "Radio Facts" FREE**  
A. G. Mohaupt, Radio Engineer, RADIO ASSOCIATION OF AMERICA, 4513 Ravenswood Ave., Dept. 26, CHICAGO



# WITH THE MANUFACTURERS



## New Loud Speaker

Radio listeners who now demand not only volume and quality of tone, but pleasing appearance, will find in the new Western Electric No. 14-A Loud Speaking Telephone Outfit an efficient cabinet type of instrument that makes use of the latest developments in the electrical communication art. It is a combined loud speaking telephone and audio-frequency amplifier. This outfit, including the horn, is built into a mahogany cabinet of attractive design, which may be placed on a table.

The novel feature of this outfit is the horn, which, folded into a relatively small compass, has yet the properties of a straight horn almost twice as long as the cabinet is deep. Despite its small size, it is more effective even than the horn supplied with the 10-A and 10-D loud speaking telephone outfits. Connected to the horn is a loud speaking telephone similar to that used on many occasions to project the voices of speakers, notably at the inauguration of the late President Harding.

Two stages of audio-frequency amplification are provided, the last stage using two tubes connected in "push-pull." This arrangement gives the maximum output with practically no distortion of the quality of the transmission. Volume control is effected by turning a knob on the front of the cabinet; this varies the audio voltage applied to the grid of the first tube. A snap-switch, also controlled from the front, turns on and off the filament current.

The outfit has been designed to operate with No. 216-A tubes, which are designed to work on a 6-volt storage battery. Plate current supply may be secured from any battery which will give 22 milliamperes at 120 to 135 volts. Six large size 22½-volt "B" batteries may be used, or a Western Electric No. 2-A Current Supply Set will furnish both filament and plate current.

Since this outfit can do no more than give an amplified reproduction of the output of a radio receiver, it is important that the latter be capable of giving an output of good quality and of sufficient volume to be satisfactory to a listener using a telephone head set. It should be remembered that this outfit is in no sense a radio receiver or tuning device.

## British Interest Grows

Enthusiasm for radio telephony continues to grow throughout Great Britain, according to Acting Commercial Attache Hugh A. Butler. Up to March 1, 1924, over 600,000 licenses for receiving sets had been issued.

## Electrad Variohm On Market

Considerable popularity for Electrad's new "Variohm" has been reported by dealers throughout the country. It is said to be the newest thing in variable grid leaks, being unusually compact and taking up little room on either panel or inside the set.

A complete range of resistances in one unit is afforded, ranging from one-fourth to ten megohms. The Variohm is non-microphonic, moisture proof, saves B batteries and does away with circuit noises, according to a circular sent to dealers by Electrad, Inc., of New York City. Another advantage is the elimination of local stations and the opportunity to receive distant stations without interference.

## On Freed-Eisemann Force



EDGAR K. JAMES

Amateurs all over the United States know Edgar K. James, who conducted the first radio show for amateurs, and assisted in the latest show held in the Pennsylvania Hotel, New York. He has always been active in amateur radio and is a member of the Second District Executive Radio Council. During the war he was instructor at McCook's field in Dayton, Ohio, and in 1919 he started the radio department for Stanley & Paterson, radio jobbers. He was with the De Forest Company two years, and two years with the A. H. Grebe Company in Richmond Hill, L. I. Now the Freed-Eisemann Radio Corporation have him, and he is out doing a big job in the Eastern territory.

## Four Brazilian Stations

Permission to establish four radio broadcasting stations has been granted by the Ministry of Public Works of Brazil to the Brazilian Radio Telegraph Company for the purpose of broadcasting information, lectures, concerts, etc. The four stations are to be located at Sao Paulo, Bello Horizonte, Bahia, and Pernambuco.

## The Inside of a Radio Factory

By E. J. Craine

The inside of a radio factory is like nothing else in the world but a gigantic bee-hive, and one of its chief points of similarity is the promptness with which drones must be eliminated.

The same curiosity that makes a small boy want to see the inside of a watch urges the average "fan" to see the inside of a radio factory. The results, however, are not so disastrous in a radio plant, although a feeling of awe casts its spell throughout.

## Visits Freed-Eisemann

It was to Joseph D. R. Freed that I confided my longing to visit the Freed-Eisemann organization in Brooklyn.

The first room I entered was filled with a huge pile of panels, several feet deep and still enclosed in their white wrappings. Nearby, workmen were drilling four panels simultaneously and with the greatest care, with machines that are set with mathematical accuracy.

Once drilled, the edges of the panels are smoothed, and then, with a battery of ten huge machines that look like overgrown drawing toys, the name, "Freed-Eisemann" is engraved, as well as the various names which indicate dial numbers, etc.

Rows and rows of benches where expert workmen were winding coils were found in an adjoining room. Other workmen varnish the coils with a secret preparation, after which they were left to dry. Coils and condensers are then attached to the panel, which soon begins to be recognizable, with its three coils, four posts, and tube shelf.

Soldered parts are given the closest scrutiny and wiring is tested by experts. Every speck of dust is blown out with a strong compressed air blower. Not the smallest detail is left to chance, and each step in the work of construction is tested. If any part falls under perfection, it is sent back and often broken up.

When a set is still in embryo state it is given a long tag and in the course of completion each man who contributes to its construction signs his name to the tag; so, when the set finally stands forth, every worker's signature is there. These tags are filed in order that inferior workmanship can be traced.

## Tested for Flaws

In the engineer's department the receiver is neutralized and tested again for any possible flaw. When the apparatus is finally enclosed in its cabinet it is sent to a "laboratory" where it must run the gauntlet of examination and test. After



passing through the hands of many skilled workmen it is enclosed in a carton.

Air chambers protect the set perfectly in the carton, keeping it absolutely safe until it arrives at its destination.

The Freed-Eisemann plant occupies about 25,000 square feet. More than 400 workmen are employed in the factory.

**Phonograph Dealers Interested**

Phonograph dealers recently have shown considerable interest in radio. The increased publicity being devoted to radio is expected to result in more sales for phonograph concerns as well as all classes of stores who sell radio.

To "tie in" with this activity, the Manhattan Electrical Supply Company is offering for sale a new phonograph attachment under their trade mark, "Red Seal." It consists of a special Red Seal receiver attached to a heavy non-resonant metal base with air chamber and diaphragm especially designed to operate the large air column of a reproducing horn.

Attachment is made to the tone arm of the phonograph by means of a soft rubber tube. This new attachment is very sensible to faint signals and re-creates musical programs faithfully.

**New Managers for Goldschmidt**

John B. Price and Harry Kamen have been appointed to district managerships by the Goldschmidt Corporation. Mr. Price has been chosen New York district manager and will have charge of the supervision of sales of N & K Imported Phones, loud speakers and other products which the Goldschmidt Corporation plans to put on the market soon in Northern New Jersey, greater New York, New York State and Long Island.

Mr. Kamen will have charge of the New England district and will handle the same products as Mr. Price. Mr. Kamen has been connected for twelve years with the A. C. Gilbert Company of New Haven, Conn., in the electrical specialty business.

**Cruver Has New Condenser**

The Cruver Manufacturing Company, Chicago, has just put out a new condenser, invented and designed by G. M. Proudfoot, their engineer. The condenser cuts down the inefficient capacities by means of mounting the stator plates on two rods instead of three, thereby reducing losses to a negligible quantity.

The 23-plate condenser showed the same reading at maximum capacity and 200 meters as the standard used, which is said to have a loss of only seven one-thousandths of one per cent at a capacity of .001 M. F. The model was used in the Trans-Atlantic test in the "low loss" tuner designed and operated by F. J. Marco of Experimental Station 9XBA, Chicago.

When the group plates are set for the coarse adjustment, the reading shows on the large scale. The knob is then turned in the opposite direction and the fine adjustment is read on the inner scale, thus enabling an accurate log to be obtained.

**Chicago Radio Makers Unite**

The Associated Radio Manufacturers, an organization of manufacturers who will produce \$150,000,000 worth of radio sets during 1924, has been organized in Chicago as a means of maintaining radio trade relations and increasing the efficiency of radio products.

Many of the big radio manufacturers in the Chicago district are represented in the new organization. They place their 1924 production estimate at a minimum of \$150,000,000. More than 2,000,000 transformers alone are expected to be turned out. In the manufacture of radio sets the Zenith Radio Corporation has fixed its minimum at \$3,500,000 worth of sets.

With the industry traveling along at such a lively clip, the manufacturers decided to get together and enlist their co-operation in a drive to eliminate the evils of radio reception as well as the evils offered by those who attempt to foist inferior apparatus on the radio public.

Herbert H. Frost, A. J. Carter, Frank Reichman, A. A. Howard and E. N. Rauland were elected as a temporary board of directors.

At the first general organization meeting the following firms were enrolled:

Rauland Manufacturing Company, Howard Radio Company, Carter Radio Company, Herbert H. Frost, Inc., Belden Manufacturing Company, Premier Electric Company, Bremer-Tully Manufacturing Company, Dudlo Manufacturing Company, Trimm Radio Manufacturing Company, Runzel-Lenz Electrical Manufacturing Company, Multiple Electric Products Company, American Art Mache Company, Seaman Paper Company, Electrical Research Laboratories, Walbert Manufacturing Company, Winkler-Reichman Company, Buehl Manufacturing Company, French Battery Company, Zenith Radio Corporation.

**G. A. Sawin Elected**

G. A. Sawin, assistant to manager, Supply Sales Department, Westinghouse Electric and Manufacturing Company, has been elected chairman of a new section of the Electric Power Club. The section, including instruments and instrument transformers, was recently organized.

Mr. Sawin, who is chairman of the Instruments and Measurements Committee of the American Institute of Electrical Engineers, has also been appointed chairman of the Institute's section for revising the Institute's standardization rules pertaining to instrument transformers.

His wide experience with instruments and transformers will be of great aid to Mr. Sawin in the new duties assigned him.

**Jacquet With National Carbon**

Lloyd Jacquet, formerly with the Westinghouse Electric, has recently been placed in charge of the publicity section of the National Carbon Company's radio division. Previous to his connection with Westinghouse, Mr. Jacquet was radio editor of the New York Evening Mail.

**Now you can UNDERSTAND RADIO!**

Take the mystery out of it—build and repair sets—explain the vacuum tube—operate a transmitter—be a radio expert!



**1 VOLUME  
514 PAGES**

Compiled by  
**HARRY F. DART  
E.E.**

Formerly with the  
Western Electric  
Co., and U. S.  
Army Instructor  
of Radio.

**Technically Edited by F. H. Doane  
40,000 ALREADY SOLD**

This practical and authoritative Handbook is considered the biggest dollar's worth in radio to-day. Over 40,000 homes rely on the I. C. S. Radio Handbook to take the mystery out of radio. Why experiment in the dark when you can quickly learn the things that insure success! Hundreds of illustrations and diagrams explain everything so you can get the most out of whatever receiver you build or buy.

It contains: Electrical terms and circuits, antennas, batteries, generators and motors, electron (vacuum) tubes, many receiving hook-ups, radio and audio frequency amplification, broadcast and commercial transmitters and receivers, wave meters, super-regeneration, codes, license rules. Many other features.

A practical book. Written and edited by experienced engineers, in plain language. Something useful on every one of its 514 pages. The authority that covers every phase of radio, all under one cover in one book for one dollar. Don't spend another cent for parts, turn a dial or touch a tool until you have mailed \$1 for this I. C. S. Radio Handbook.

Send \$1 at once and get this 514-page I.C.S. Radio Handbook—the biggest value in radio to-day. Money back if not satisfied.

— TEAR OUT HERE —

**INTERNATIONAL CORRESPONDENCE SCHOOLS**  
Box 8785, Scranton, Penna.

I enclose One Dollar. Please send me—post-paid—the 514-page I. C. S. Radio Handbook. It is understood that if I am not entirely satisfied I may return this book within five days and you will refund my money.

Name .....

Address .....

**YOU DON'T NEED TUBES**

to hear programs from stations 400 to 1,000 Miles Away. I can show you how to get them on YOUR CRYSTAL SET. Changes often cost Less Than One Dollar. Send self-addressed envelope for picture of my set.

**LEON LAMBERT**  
540 So. Volusia, Wichita, Kansas

**AUTHENTIC—ACCURATE  
RADIO AGE  
MONTHLY DATA SHEETS  
Pages 37 and 39, This Issue**

# Evils of Home Broadcasting

By L. O. MARSTELLER

**T**HE trouble caused by an amateur's innocently operating his receiving set as a miniature broadcasting station is a radio bug-bear that can easily be overcome with a little thought and study on the subject of radio interference.

Nearly all the sensitive receiving sets in use are capable of broadcasting speech and music. This can readily be done by the use of a microphone properly connected to a receiving set.

A microphone is a simple little device, one form of which we use every day; namely, the part of the telephone into which we talk. Talking into a very sensitive microphone causes the voice to affect the powerful radio waves sent out by the transmitter, which is fundamentally a large sensitive receiving set having a microphone connected to it. The tickler on the transmitter is necessarily adjusted so as to make the circuit oscillate and consequently transmit radio waves just as your receiving set will do with a similar tickler adjustment.

If I thought that you would use the microphone only to reprimand your neighbor, who is causing his receiving set to transmit whistles and squeals, then I certainly would explain how to connect the device to your set. However, there is always the possibility of the ladies broadcasting tea party gossip or the uncanny East or West wind from a Mah Jong party, so I shall leave the home broadcasting idea for you to think about.

The purpose of mentioning the possibility of using the receiving set as a broadcasting station is to call your attention to the power you control with the knobs and dials on your set.

If you do not have a microphone connected to your receiving set, you can still transmit, but it will be whistles and squeals which are a source of interference to your neighbors.

## Whence That Squeal?

Many times during the reception of an interesting program, one will hear a whistle or squeal caused by a neighbor who improperly manipulates the controls of his set. The fact that he can very easily prevent such interference is an excellent reason for paying him a visit and explaining the situation. Before paying your neighbor this instructive visit, however, it would be well to learn the cause, effect and remedy for such interference.

There are several types of receiving sets which can be made to act as a transmitter. The first of these is the favorite set, a single circuit receiver. There are two controls on a single circuit receiver. One of these controls is known as a tuner handle or knob. This control makes it possible to tune in one station and eliminate another. The other control is a tickler or intensifier. Its purpose is to increase the signal strength. Both tuner and tickler should be operated simultane-

ously. Now let us consider the proper operation of this set.

With the tickler set near zero, bring the tuner control to approximately the setting where you would expect to find the desired signal, and, with the other hand, bring the tickler control up to the point where a slight hiss or rustle is heard and keep the tickler so adjusted as you more accurately tune in the signal.

If a slight change of the tuner adjustment causes a squeal or whistle to be heard, you should immediately remedy matters by decreasing the tickler until the whistle disappears. If you do not decrease the tickler setting, your set will continue to act as a transmitter and radiate an interfering wave. This will cause your neighbors to receive a whistle like noise mixed in with the concert music from the broadcasting station. Many times music of excellent quality is condemned because of the interference caused by the wave sent out from a neighbor's receiving set.

With a very little practice the single circuit receiving set can be operated night after night without causing any interference.

## The Three Control Type

Another type of receiver which often finds a place in the amateur's home and sometimes is used for broadcast reception, has one more control than the single circuit set, making a total of three controls.

One control tunes the primary or antenna circuit and the other tunes the secondary or tube circuit. The third control is marked tickler or intensifier. This receiver is very selective, but requires considerable skill and patience in order to tune in weak signals. As this type of receiver has three controls, it is rather difficult to keep the tickler properly adjusted as the primary and secondary controls are operated. The general tendency is to set the tickler to maximum and then tune the primary and secondary until the whistle like note of a broadcasting station is heard.

For people who only have two hands, there is only one way to operate such a set and not cause interference; that is, to calibrate the secondary circuit by marking the proper setting down on a chart. Then to tune in a station it is only necessary to set the secondary control to the proper point as determined from the calibration chart and adjust the tickler to the point where a slight hiss or rustle is heard as the primary circuit is tuned to the desired signal.

There is one other receiver which is commonly used. This receiver causes a great amount of interference, as it has three tuned circuits. Two of the controls are marked primary and secondary and are manipulated to tune in a signal. The third control acts as a tickler and has a definite adjustment for each adjustment

of the secondary circuit. With this type of receiver, it is almost impossible to tune in a station without radiating an interfering wave. Every time that the third control is tuned to the secondary circuit, an interfering wave will be radiated.

## Can Be Heard Six Blocks

How far will any one or all of these three types of receivers transmit? Any one will cause interference over a distance of four city blocks and can under most favorable conditions be heard six blocks away.

Possibly the evil has been recognized in the cities where so many receiving sets must be used within a small area, and, that greater co-operation between neighbors has necessarily been obtained.

## Sophs' Radio Party Spoiled

Troy, N. Y.—When the Class of 1926 of the Rensselaer Polytechnic Institute staged its big social event, the Sophomore Soiree, the students wanted the whole world to know they were having a good time.

And the world would have known it if the envious freshmen hadn't known something about radio.

The sophomores had persuaded Station WHAZ to hook up with the 105th Regiment Armory, where the event was being held, and put the syncopated music of Ben Selvin and his Moulin Rouge Orchestra on the air.

Wires, microphone pickups and electricians were placed in their proper places, and on tests held early in the evening everything worked perfectly. After local broadcasting stations closed for the night the announcement was sent out that WHAZ would broadcast the student affair. Radio listeners settled back to hear the jazz music and gay laughter.

But something went wrong. There came occasional strains of music, interrupted by long periods of silence. The radio men were stumped; they inspected the apparatus, changed the microphone and tested the wires—but still no music came forth, although the orchestra was playing for all it was worth.

It was the first time in two years that the station's program had been spoiled. After several hours' investigation the "experts" discovered that in an obscure place back of the Sage dining hall the transmission wires had been tapped in two places with leads to the ground.

After a little sleuthing, the investigators forced a group of freshmen to confess they had tapped the wires and inserted a microphone intended to broadcast remarks harmful to their hated rivals—the sophomores. Fortunately the second microphone did not work, but the frosh took solace in the fact the sophomores' program was not broadcast to a wondering world.

# Radio Age and "QST"—

## \$4.50 in Subscription Value for Only \$3.00

Two yearly subscriptions for slightly more than the regular cost of one. An extraordinary offer for a limited period. Quick decision will save you from \$1.90 to \$2.40. Radio Age, purchased each month on the newsstand, would cost you \$3.00. "QST" would cost you \$2.40. The regular subscription rate for Radio Age is \$2.50. For "QST" it is \$2.00.

The two magazines, together, cover the radio field.

"QST" is the official organ of the American Radio Relay League. It is devoted entirely to amateur radio and is a standard publication on technical facts connected with radio.

Radio Age is in the front rank as a magazine for the set maker and the broadcast listener. It is the hand-book of thousands of experimenters in home workshops.

Best isometric drawings of standard circuits; clearly written, **complete** descriptions of construction details; complete corrected list of broadcasting stations **revised each month**; news of latest developments in radio; calls heard by amateurs; new designs and equipment; scientific data. All this for \$3.00 a year.

Mail The Coupon Today!

### RADIO AGE, Inc.

500 No. Dearborn Street,  
Chicago, Ill.

Send me Radio Age and "QST," the two popular radio monthly magazines, for one year, twelve months each. I enclose \$3.00 in full payment.

Name.....

Address.....

(Canada, \$3.50; Foreign, \$4.00)

# Corrected List of U. S., Cuban and Canadian Broadcasting Stations

## Complete Each Issue

THE list of broadcasting stations on these pages is brought up to date each month by additions of new stations and deletion of those which have suspended operation. The list is the product of a vast volume of correspondence and its completeness is due in large measure to the assistance of our special news service in Washington, D. C. Suggestions, corrections and additional data will be welcomed from readers and broadcasters.

KDKA	Westinghouse Electric & Mfg. Co.	East Pittsburgh	326	KFLH	Erickson Radio Co.	Salt Lake City, Utah	261
KDPM	Westinghouse Electric & Mfg. Co.	Cleveland, Ohio	270	KFLP	Everette M. Foster	Cedar Rapids, Iowa	240
KDYL	Western Electrical Co.	San Diego, Calif.	244	KFLR	Bizzell Radio Shop	Little Rock, Ark.	261
KDYM	Telegram Publishing Co.	Salt Lake City, Utah	264	KFLS	University of New Mexico	Albuquerque, N. Mex.	254
KDYM	Sevroy Theatre	Salt Lake City, Utah	244	KFLU	San Benito Radio Supply House	San Benito, Texas	256
KDYX	Oregon Institute of Technology	Portland, Ore.	360	KFLV	Rev. A. T. Frykman	Rockford, Ill.	229
KDZB	Star Bulletin	Honolulu, Hawaii	360	KFLW	Missoula Electric Supply Co.	Missoula, Mont.	234
KDZC	Frank E. Siefert	Bakersfield, Calif.	240	KFLX	George Roy Clough	Galveston, Tex.	240
KDZE	Rhodes Department Store	Seattle, Wash.	270	KFLY	Fargo Radio Supply Co.	Fargo, N. Dak.	231
KDZI	Electric Supply Co.	Wenatchee, Wash.	360	KFM	Atlantic Automobile Co.	Atlantic, Ia.	273
KDZQ	Nichols Academy of Dancing	Denver, Colo.	360	KFMQ	University of Arkansas	Fayetteville, Ark.	263
KDZR	Bellingham Publishing Co.	Bellingham, Wash.	261	KFMR	Morningside College	Sioux City, Iowa	261
KFAD	McArthur Bros. Mercantile Co.	Phoenix, Ariz.	360	KFMS	Freimuth Dept. Store	Duluth, Minn.	275
KFAE	State College of Washington	Pullman, Wash.	330	KFMT	Dr. George W. Young	Minneapolis, Minn.	231
KFAF	Western Radio Corp.	Denver, Colo.	360	KFMT	Stevens Bros.	San Marco, Tex.	240
KFAJ	University of Colorado	Boulder, Colo.	360	KFMW	M. G. Sateren	Houghton, Mich.	266
KFAN	The Electric Shop	Moscow, Idaho	360	KFMX	Carleton College	Northfield, Minn.	289
KFAR	Studio Lighting Service Co. (O. K. Olsen)	Hollywood, Calif.	280	KFMY	Baylor University	Waco, Tex.	234
KFAU	Independent School Dist. of Boise City, Boise High School	Boise, Idaho	270	KFMZ	Roswell Broadcasting Club	Roswell, N. M.	252
KFAW	The Radio Den (W. B. Ashford)	Santa Ana, Calif.	280	KFN	Alonso Monk, Jr.	Corsicana, Texas	232
KFAZ	W. J. Vitgrin	Medford, Ore.	283	KFNH	Henry Field Seed Co.	Shenandoah, Iowa	266
KFB	F. A. Birtney & Co.	Havre, Mont.	360	KFNK	Wooten's Radio Shop	Coldwater, Miss.	254
KFB	W. K. Azbill	San Luis Obispo, Calif.	242	KFNK	State Teachers College	Springfield, Mo.	236
KFB	Renaissance Central High School	San Luis Obispo, Calif.	242	KFNK	Easter Electric Radio Shop	Warrsburg, Mo.	234
KFB	First Presbyterian Church	Tacoma, Wash.	360	KFNL	Radio Broadcast Ass'n.	Paso Robles, Calif.	240
KFBK	Kimball-Upson Co.	Sacramento, Calif.	283	KFNV	L. A. Drake Battery and Radio Supply Shop	Santa Rosa, Calif.	234
KFB	Leese Bros.	Everett, Wash.	224	KFNX	Peabody Radio Service	Peahody, Kansas	240
KFBS	Trinidad Gas & Electric Supply Co. and the Chronicle News	Trinidad, Colo.	360	KFNY	Montana Phonograph Co.	Helena, Montana	261
KFB	The Cathedral (Bishop N. S. Thomas)	Trinidad, Colo.	283	KFNZ	Royal Radio Company	Burlingame, Calif.	231
KFCB	Nielson Radio Supply Co.	Phoenix, Ariz.	238	KFO	First Christian Church	Whittier, Calif.	236
KFC	Frank A. Moore	Walla Walla, Wash.	360	KFO	Vern Peters	Wallace, Idaho	224
KFC	Electric Service Station (Inc.)	Billings, Mont.	360	KFO	Rohrer Electric Co.	Marshfield, Oregon	240
KFCP	Ralph W. Flygare	Ogden, Utah	360	KFO	The Radio Bungalow	Portland, Oregon	283
KFCV	Fred Mahaffey, Jr.	Houston, Texas	360	KFO	Moberly High School Radio Club	Moberly, Missouri	246
KFCY	Western Union College	Le Mars, Iowa	252	KFO	Leslie M. Schafbusch	Marengo, Iowa	234
KFCZ	Omaha Central High School	Omaha, Neb.	258	KFO	Chophone Radio Shop	Long Beach, Calif.	261
KFDA	Adler's Music Store	Baker, Ore.	360	KFO	Dayton Electric Radio Shop	Salt Lake City, Utah	234
KFDD	St. Michaels Cathedral	Boise, Idaho	252	KFO	Willson Construction Co.	Dallas, Texas	268
KFDD	University of Arizona	Tucson, Ariz.	368	KFO	Ora William Chancellor	Galveston, Texas	240
KFDD	Oregon Agricultural College	Corvallis, Ore.	360	KFO	David City Tire & Electric Co.	David City, Nebraska	226
KFDD	H. Everett Cutting	Bozeman, Mont.	248	KFO	College Hill Radio Club	Wichita, Kansas	231
KFDR	Ballocks Hardware & Sporting Goods (Rob. G. Bullock)	Fayetteville, Ark.	360	KFO	Hommel Mfg. Co.	Richmond, Calif.	234
KFDV	Gilbreth	Fayetteville, Ark.	360	KFO	Dayton Electric Corporation	Warrsburg, Mo.	234
KFDX	First Baptist Church	Shreveport, La.	360	KFO	Board of Education, Technical High School	Omaha, Nebraska	248
KFDY	South Dakota State College of Agriculture and Mechanics Arts	Brookings, S. Dak.	360	KFO	Beacon Radio Service	St. Paul, Minn.	226
KFDZ	Harry O. Iverson	Brookings, S. Dak.	360	KFO	Leon Hudson Real Estate Co.	Fort Smith, Ark.	233
KFE	Meigs & Frank Co.	Minneapolis, Minn.	231	KFO	Edwin J. Brown	Seattle, Wash.	224
KFE	Winner Radio Corp.	Portland, Ore.	360	KFO	Garretson and Dennis	Los Angeles, Calif.	238
KFE	J. L. Scroggin	Portland, Ore.	360	KFO	Karol Chas. Mailander	Salt Lake City, Utah	242
KFER	Auto Electric Service Co.	Fort Dodge, Iowa	231	KFO	C. Baxter	Dublin, Texas	242
KFEV	Radio Electric Shop	Douglas, Wyo.	263	KFO	The New Furniture Co.	Greenville, Texas	242
KFEX	Augsburg Seminary	Minneapolis, Minn.	261	KFO	Missouri National Guard	Jefferson City, Mo.	242
KFEY	Bunker Hill & Sullivan Mining and Concentrating Co.	Kellogg, Idaho	360	KFO	G. & G. Radio & Electric Shop	Olympia, Washington	236
KFEZ	Asso. Eng. Societies of St. Louis	St. Louis, Mo.	248	KFO	Clifford M. Esler	Denison, Texas	231
KFF	Jenkins Furniture Co.	Boise, Idaho	240	KFO	Los Angeles Co. Forestry Dept.	Los Angeles, Calif.	231
KFF	Eastern Oregon Radio Co.	Pendleton, Ore.	360	KFO	Roos Motor Service Co.	Casper, Wyo.	242
KFF	Dr. E. H. Smith	Hillsboro, Ore.	229	KFO	Heintz & Kohlmoos, Inc.	San Francisco, Calif.	236
KFF	First Baptist Church	Moberly, Mo.	266	KFP	St. Johns M. E. Church, S.	Carterville, Mo.	268
KFF	Markshetel Motor Co.	Colorado Springs, Colo.	360	KFP	Symons Investment Co.	Spokane, Wash.	283
KFF	Nevada State Journal (Jimi Kirk)	Sparks, Nev.	248	KFP	First Presbyterian Church	Pine Bluff, Ark.	242
KFF	Granadland College	Lamoni, Iowa	360	KFP	Angelus Temple	Los Angeles, Calif.	278
KFF	McGraw Co.	Omaha, Neb.	278	KFP	Charles D. Herrold	Pittsburgh, Pa.	270
KFF	Pineas & Murphy	Alexandria, La.	275	KFP	Hallock & Watson Radio Service	Portland, Ore.	360
KFF	Al. G. Barnes Amusement Co.	Dallas, Tex. (portable)	226	KFP	Northwestern Radio Mfg. Co.	Portland, Ore.	360
KFG	Louisiana State University	Baton Rouge, La.	254	KFP	General Electric Co.	Oakland, Calif.	312
KFG	Chickasha Radio & Electric Co.	Chickasha, Okla.	273	KFP	Marion A. Mulroney	Honolulu, Hawaii	Waikiki Beach
KFG	Stanford University	Stanford University, Calif.	273	KFP	Portland Morning Oregonian	Portland, Ore.	360
KFGL	Arlington Garage	Arlington, Ore.	234	KFP	St. Martin's College (Reb. Sebastian Ruth)	Washington, D. C.	256
KFGV	Crary Hardware Co.	Boone, Iowa	226	KFP	Tim Miritor Co.	Los Angeles, Calif.	395
KFGV	Heidbreder Radio Supply Co.	Utica, Neb.	224	KFP	Louis Wasmer	Seattle, Wash.	360
KFGV	First Presbyterian Church	Orange, Tex.	260	KFP	C. O. Gould	Stockton, Calif.	360
KFGZ	Emmanuel Missionary College	Berrien Springs, Mich.	267	KFP	Northwest Radio Service Co.	Seattle, Wash.	270
KFH	Western Post (College of Colorado)	Denver, Colo.	222	KFP	Bible Institute of Los Angeles	Los Angeles, Calif.	360
KFH	Rialto Theatre (P. Beardwell)	Hood River, Ore.	280	KFP	Werner Brothers Radio Supplies Co.	Los Angeles, Calif.	360
KFHD	Utz Electric Shop Co.	St. Joseph, Mo.	226	KFP	Tribune Publishing Co.	Oakland, Calif.	509
KFH	Central Christian Church	Shreveport, La.	266	KFP	Reynolds Radio Co.	Denver, Colo.	509
KFH	Ambrose A. McCue	Neah Bay, Wash.	283	KFP	San Joaquin Light & Power Corp.	Fresno, Calif.	273
KFH	Fallon & Co.	Santa Barbara, Calif.	360	KFP	Love Electric Co.	Tacoma, Wash.	360
KFH	Star Electric & Radio Co.	Seattle, Wash.	270	KFP	Grays Harbor Radio Co. (Walter Hemrich)	Aberdeen, Wash.	263
KFH	Robert Nelson	Hutchinson, Kan.	229	KFP	Electric Lighting Supply Co.	Los Angeles, Calif.	360
KFI	Earle C. Anthony (Inc.)	Los Angeles, Calif.	469	KFP	New Mexico College of Agriculture & Mechanic Arts	State College, N. Mex.	360
KFI	Ross Arbuckle's Garage	Iola, Kans.	246	KFP	Detroit Police Department	Detroit, Mich.	286
KFI	Benson Polytechnic Institute	Portland, Oregon	360	KFP	Hale Bros.	San Francisco, Calif.	423
KFI	Windisch Electric Farm Equipment Co.	Louisburg, Kans.	234	KFP	Apple City Radio Club	Hood River, Ore.	360
KFI	North Central High School	Spokane, Wash.	252	KFP	Douthead-Hill Electric Co.	Pittsburgh, Pa.	270
KFI	Valley Radio Broadcasting Association	Yuma, Wash.	224	KFP	V. C. Battery & Electric Co.	San Jose, Calif.	360
KFI	Alaska Electric Light & Power Co.	Juneau, Alaska	226	KFP	Post Dispatch (Pulitzer Pub. Co.)	Berkeley, Calif.	278
KFI	V. H. Brovles	Pittsburg, Kans.	240	KFP	First Presbyterian Church	St. Louis, Mo.	546
KFI	Reorganized Church of Jesus Christ of Latter Day Saints	Independence, Mo.	240	KFP	Examiner Printing Co.	Seattle, Wash.	360
KFI	Daily Commonwealth and Oscar A. Huelsman	Fon Du Lac, Wis.	273	KFP	Coast Radio Co.	San Francisco, Calif.	360
KFI	Seattle Post-Intelligencer	Seattle, Wash.	233	KFP	Portable Wireless Telephone Co.	Stockton, Calif.	360
KFI	National Radio Manufacturing Co.	Oklahoma City, Okla.	252	KFP	Los Angeles Examiner	Los Angeles, Calif.	360
KFI	Liberty Theatre (E. E. Marsh)	Astoria, Ore.	252	KFP	Electric Shop	Honolulu, Hawaii	270
KFI	Delano Radio and Electric Co.	Bristow, Okla.	233	KFP	Westinghouse Electric & Mfg. Co.	Chicago, Ill.	536
KFI	Hardaeg Manufacturing Co.	Ottumwa, Iowa	242	KFP	Preston D. Allen	Oakland, Calif.	360
KFI	University of North Dakota	Grand Forks, N. Dak.	280	KFP	Cope and Johnson Co.	Salt Lake City, Utah	268
KFI	Nassau Bros. Radio Co.	Grand Forks, N. Dak.	280	KFP	Wenatchee Battery & Motor Co.	Wenatchee, Wash.	360
KFI	Ashley C. Dixon & Son	Stevensville, Mont. (near)	258	KFP	Tulane University	New Orleans, La.	268
KFI	Thomas H. Warren	Dexter, Iowa	224	KFP	Ohio Mechanics Institute	Cincinnati, Ohio	360
KFI	Iowa State Teachers' College	Cedar Falls, Iowa	229	KFP	Chicago Daily Drivers Journal	Chicago, Ill.	286
KFI	Tunwall Radio Co.	Fort Dodge, Iowa	248	KFP	Gimbel Brothers	Milwaukee, Wis.	280
KFI	Texas National Guard, One hundred and twelfth Cavalry	Fort Worth, Texas	254	KFP	University of Missouri	Newark, N. J.	283
KFI	Colorado State Teachers College	Greeley, Colo.	248	KFP	Omaha Grain Exchange	Omaha, Neb.	360
KFI	Brinkley-Jones Hospital Association	Milford, Kans.	286	KFP	Lake Forest College	Lake Forest, Ill.	266
KFI	Conway Radio Laboratories (Ben H. Woodruff)	Conway, Ark.	224	KFP	Harrisburg Sporting Goods Co.	Harrisburg, Pa.	286
KFI	P. F. Gray	Butte, Mont.	283	KFP	Parker High School	Dayton, Ohio	263
KFI	Westinghouse Electric & Manufacturing Co.	Hastings, Neb.	283	KFP	Young Men's Christian Association	Washington, D. C.	483
KFI	Nassau Bros. Radio Co.	Colorado Springs, Colo.	244	KFP	Lake Shore Tire Co.	Jacksonville, Fla.	248
KFI	Abney & Willson	Butte, Mont.	283	KFP	Banzor Railway & Electric Co.	Banzor, Me.	240
KFI	Signal Electric Manufacturing Co.	Menominee, Mich.	248	KFP	Connecticut Agricultural College	Storrs, Conn.	283
KFI	Paul E. Greenlaw	Franklington, La.	234	KFP	F. E. Doherty Automotive and Radio Equipment Co.	Saginaw, Mich.	254
KFI	National Educational Service	Denver, Colo.	248	KFP	Waldo C. Grover	La Crosse, Wis.	244

# If You Sell Radio Mer- chandise By Mail

Radio Age Covers the Con-  
tinent. 183,000 copies  
printed and distributed in the  
first three months of 1924.

JANUARY ..... 50,000  
FEBRUARY ..... 63,000  
MARCH ..... 70,000  
APRIL PRESS RUN 73,000

Radio Age is an applicant  
for membership in the Audit  
Bureau of Circulations, a fact  
that will interest advertisers  
who insist upon verified circula-  
tion.

Radio Age has wholesale  
distributors and news dealers  
in every important center in  
the United States and Canada.

Radio Age advertising pro-  
duces results. National adver-  
tisers are signing up for time  
contracts. They know.

Every buyer of Radio Age  
is a radio fan. The magazine  
offers a highly specialized cir-  
culation. Advertisers reach ex-  
actly the circulation they are  
paying to reach.

Can we send you  
a rate card?

**RADIO AGE, Inc.**  
506 NORTH DEARBORN ST.  
CHICAGO, ILLINOIS

### Evolution of a Condenser

Originally all condensers were of the fixed type, and alternate sheets of glass and tin foil had to be built up to secure the capacities required or to tune in the wave length desired, according to a circular issued by the Charles Freshman Company, Inc.

Then came sliding plates of metal which intermeshed with opposing plates, thus giving an adjustable capacity. From the simple sliding plate type, the next step was to mount one set on a rotating shaft and by simply turning the shaft, variation in capacity was secured.

The "Freshman Selective" type has been put on the market as the latest in variable condensers. Using walls of mercury separated by a sturdy sheet of mica, the Freshman condenser secures capacity ranges by varying the area of the mercury walls. The operation is simple, the dial setting corresponding to capacity variation or wave lengths the same as any other condenser.

### A. M. Joralemon Joins Crosley

The appointment of A. M. Joralemon as general sales manager of The Crosley Radio Corporation, Cincinnati, brings another executive to the organization which has grown so rapidly in the past three years under the guidance of Powel Crosley, Jr., its president. The new executive, who joined the organization April first, needs no introduction to the radio industry, for he has been with the National Carbon Company, in managerial capacity, for the past fourteen years. His most recent endeavors were as sales manager of the radio division of that company.

## Heterodyne Troubles Overcome by

*Pfanstiehl*

### Oscillator

\$6.00

Postpaid,  
or at your  
dealers.

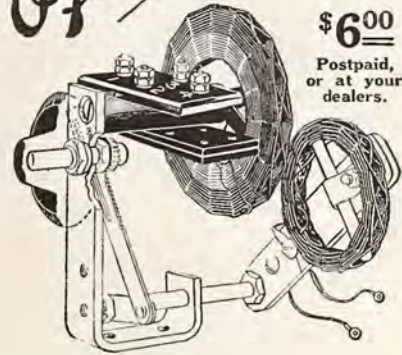

### Because

1. Pfanstiehl Oscillator adjusts the strength of the oscillations to that of the incoming signal and eliminates distortion.
2. A proper by-pass condenser is assembled in the unit and tested with it.

**PFANSTIEHL RADIO SERVICE CO.,**  
HIGHLAND PARK, ILL.

Chicago Office, 1001 W. Washington Blvd.  
Telephone Haymarket 8010

## INTERNATIONAL BABYDYNE RECEIVER



The last word in simplified radio! This set is guaranteed to tune in over 1,000 miles.

LIST PRICE: \$10 (Without the tube).

Dealers and jobbers: This set will be the rage this summer; especially among vacationists and campers. Write for our discounts.

The above set can be coupled to a two-stage amplifier with advantage.

### INTRODUCTORY OFFER

Upon receipt of \$13.85, we will ship you the complete set including:

The Babydyne receiver. One guaranteed tube, any type. One pair of headphones. Portable style B battery, 22½ volts. One A battery, dry cell. Aerial and ground connection.

Money-back guarantee on any of the above articles.

We can supply you with standard type tubes at \$3.00 each. Write for our descriptive circular on radio tubes.

### \$50.00 IN CASH

will be given for the best acceptable plan of a case to enclose the Babydyne with tubes, batteries and headphones.

#### THE "MUST" IN THE CASE:

- It must be light.
- It must be compact.
- It must be portable style.
- It must be of fair strength.
- It must be cheap to construct.
- It must be ingenious in build.

SOMEONE of the Babydyne users will win this prize; it may be you if you send us your diagram and photograph.

### MAKE THIS SUMMER DIFFERENT FROM LAST

summer by taking advantage of our special offer. You can never forget the thrills that come in using a Babydyne on your vacation or on a motor trip. (Upon request, we will give you free information on how to enjoy a concert while auto riding.) No matter in what part of the country you may be, we guarantee that the Babydyne will tune in some stations or others. DO NOT MISS THIS OPPORTUNITY OF ACQUIRING A RADIO RECEIVER THAT MEETS ALL DEMANDS YOU WILL WONDER AT THE MONEY-GIVING VALUE BEHIND OUR OFFER!

**INTERNATIONAL  
BABYDYNE  
RADIO RECEIVER**

TRADE MARK

Manufactured by

**A. & T. RADIO COMPANY**  
Dept. B, DANVERS, MASS.

Corrected List of U. S., Cuban and Canadian Broadcasting Stations

Table listing broadcasting stations with call letters, station names, and locations. Includes stations like WABO, WABP, WABQ, etc., across various states and countries.

### Pickups & Hookups

(Continued from page 33.)

was so low that I couldn't get any point of regeneration because the last hookup I tried from still another magazine shorted my A battery. I had it charged, and was all ready to try to set Wednesday evening following, and the first station I received was KFKX of Hastings, Neb. Here are the following stations I received from 8:30 P. M. to 1:30 P. M. of the same evening. Some of these stations were testing, and it is also known that Pasadena is very hard on radio reception due to the mountains—but just take a slant at this:

KFKX, KDYL, KGG, CYB, CKCB, CFCN, KFCB, KFAW, KPO, KFNV, KLX, KGO, KFKB, and all local stations on loud speaker! Stationary variocouplers and adjustable bakelite—WOW!! I'll tell the world RADIO AGE is no joke. I'd like to make a six-stage amplifier and yell into the mouthpiece "Three cheers for RADIO AGE!"—because I don't think the yell I can emit is loud enough for a book like that!

Yours very truly,  
CLARENCE EASTON.

35 South Raymond, Room 320,  
Bradley Bldg., Pasadena, Calif.

And while you are still laughing at that one, we'll get next month's issue ready. S'long.

### A Condenser That Cuts Losses



G. M. Proudfoot, engineer for the Cruiser Manufacturing Company, has designed a new condenser for the purpose of reducing losses and inefficient capacities.

The new condenser, shown above, achieves its aim by means of stator plates mounted on two rods, instead of the traditional three.

This model was used recently in a trans-Atlantic test of a "low-loss" tuner designed by F. J. Marco, of station 9XBA, Chicago. The condenser loss was only 7-1,000 of one per cent.



## WORLD BATTERY

### Saves You 50%

Famous Guaranteed Quality and Service—Backed by Years of Successful Manufacture and Thousands of Satisfied Users.

**Prices That Save and Satisfy**

Auto Batteries	Radio Batteries
6-Volt 11 Plate, \$12.25	6-Volt 60 Amps, \$ 8.50
6-Volt 13 Plate, 14.25	6-Volt 80 Amps, 10.00
12-Volt 7 Plate, 17.00	6-Volt 100 Amps, 12.50
	6-Volt 120 Amps, 14.50
	6-Volt 140 Amps, 16.00

Special 2-Volt Storage Battery for W.D.11 and 12 tubes. Will run 200 hours on one charge. Rechargeable. \$5.00.  
Special 4-Volt Storage Battery for U.V.139 tubes. Same features as 2 Volt. \$8.00.  
Shipment express C.O.D. subject to examination. 5% Discount for cash in full with order.

**2-Yr. Guarantee Bond in Writing With Each World Storage Battery**  
proves satisfactory World performance. Mail this ad with your name and address and we will ship battery day order is received; and give you a 45-Volt "B" Battery and Hydrometer Free with each battery purchased. Write today.

**World Battery Company**  
Dept. 36, 1219 S. Wabash Ave.  
CHICAGO, ILL.

**FREE**  
45 V. B. BATTERY  
and  
HYDROMETER

See Page 36 for Special June Offer for Reinartz Fans!  
A Real Radio Bargain!

## ERLA BLUE PRINTS

Erla Receivers out-distance other sets with an almost unbelievable volume and a naturalness that cannot be distinguished from the source of reception.

This is the famous Erla Reflex Hook-up. Less than one year old—but has taken the entire nation by storm. Every listener-in raves about it and wants a set of his own immediately.

So easy to construct that anyone who can handle a screw driver can build the set complete in a surprisingly short time—about 1½ hours. Everything is so simple and easy.

### NO SOLDERING WHATEVER—ONLY A SCREW DRIVER NEEDED

The results from the Erla 3 tube is naturalness itself and cannot be improved upon. Actual size working diagrams make everything simple and easy. Every piece of apparatus and every wire is pictured in its exact place—every article needed is listed on the diagrams.

Diagrams sent same day your order is received. Send P. O. or Express Money Order or Bank draft or Bank Cashier's check. Do not send stamps or personal checks.

**Erla Hook-up Diagram Prices**

- 3 sheets for making 1 tube set 25c
- 3 sheets for making 2 tube set 35c
- 3 sheets for making 3 tube set 50c

## Frank D. Pearne

Sole Distributor of Erla Diagrams for U. S. and Canada

829 Waveland Avenue, Chicago, Ill.

Dealers, Write for Quantity Prices

Always Mention RADIO AGE When Writing to Advertisers

# Corrected List of U. S., Cuban and Canadian Broadcasting Stations

WOO Western Radio Co. Kansas City, Mo. 360	WSAD J. A. Foster Co. Providence, R. I. 261
WOS L. Bamberger & Co. Newark, N. J. 405	WSAG City of St. Petersburg (Loren V. Davis) St. Petersburg, Fla. 244
WPAB Missouri State Marketing Bureau Jefferson City, Mo. 401	WSAI United States Playing Cards Co. Cincinnati, Ohio 309
WPAC Pennsylvania State College State College, Pa. 380	WSAJ Grove City College Grove City, Pa. 360
WPAJ Donald Little Radio Co. Okmulgee, Okla. 268	WSAN Allentown Radio Club Allentown, Pa. 229
WPAL North Dakota Agricultural College New Haven, Conn. 268	WSAP Seventh Day Adventist Church New York, N. Y. 263
WPAN Superior Radio & Telephone Equipment Co. Columbus, Ohio 286	WSAR Dougherty & Welch Electrical Co. Fall River, Mass. 254
WPAP Auerbach & Guettel Topeka, Kans. 360	WSAT Donohoo-Ware Hardware Co. Plainville, Texas 268
WPAR Ward Battery and Radio Co. Winchester, Ky. 360	WSAW John J. Long, Jr. Canandaigua, N. Y. 275
WPAT St. Patrick's Cathedral El Paso, Texas 360	WSAX Chicago Radio Laboratory Chicago, Ill. 268
WPAU Concordia College Moorhead, Minn. 360	WSAY Irvin Austin (Port Chester Chamber of Commerce) Port Chester, N. Y. 233
WPAZ John R. Koch (Dr.) Charleston, W. Va. 273	WSAZ Chas. Electric Shop Pomeroy, Ohio 428
WQAA Horace A. Beale, Jr. Parkersburg, Pa. 360	WSB Atlanta Journal Atlanta, Ga. 259
WQAC E. B. Grier Amarillo, Texas 234	WSL J. & M. Electric Co. Utica, N. Y. 273
WQAD Whitall Electric Co. Waterloo, Conn. 275	WSY Alabama Power Co. Birmingham, Ala. 360
WQAE Moore Radio News Station (Edmund B. Moore) Springfield, Vt. 234	WTAB Fall River Daily Herald Publishing Co. Fall River, Mass. 248
WQAF Sandusky Register Sandusky, Ohio 240	WTAC Penn Traffic Co. Johnstown, Pa. 360
WQAL Coles County Telephone & Telegraph Co. Mattoon, Ill. 258	WTAF W. T. Gable New Orleans, La. 242
WQAN Scranton Times Scranton, Pa. 280	WTAG Kern Music Co. Providence, R. I. 258
WQAO Calvary Baptist Church New York, N. Y. 360	WTAH Carmen Ferro Belyedere, Ill. 236
WQAO Abilene Daily Reporter (West Texas Radio Co.) Abilene, Texas 360	WTAJ The Radio Shop Portland, Me. 230
WQAS Prince-Walter Co. Lowell, Mass. 266	WTAL Toledo Radio & Electric Co. Toledo, Ohio 252
WQAX Radio Equipment Co. Peoria, Ill. 360	WTAM Willard Storage Battery Co. Cleveland, Ohio 390
WRAA Rice Institute Houston, Texas 360	WTAP Cambridge Radio & Electric Co. Cambridge, Ill. 242
WRAF The Radio Club (Inc.) Laporte, Ind. 229	WTAQ S. H. Van Gordon & Son. Osseo, Wis. 220
WRAH Stanley N. Read Providence, R. I. 231	WTAR Reliance Electric Co. Norfolk, Va. 280
WRAM Northern States Power Co. St. Croix Falls, Wis. 248	WTAS Charles E. Erbstein Elgin, Ill. 275
WRAN Black Hawk Electrical Co. Galesburg, Ill. 244	WTAT Edison Electric Illuminating Co. Boston, Mass. (portable) 244
WRAO Radio Service Co. St. Louis, Mo. 360	WTAU Ruegg Battery & Electric Co. Tecumseh, Neb. 360
WRAW Antioch College Yellow Springs, Ohio 242	WTAW Ruegg Battery & Electric Co. Tecumseh, Neb. 280
WRAW Avenue Radio Shop (Horace D. Good) Reading, Pa. 238	WTAX Agricultural & Mechanical College of Texas College Station, Tex. 231
WRAZ Flaxon's Garage Gloucester City, N. J. 268	WTAY Iodair-Oak Leaves Broadcasting Station Oak Park, Ill. 220
WRAZ Radio Shop of Newark (Herman Lubinsky) Newark, N. J. 280	WTAZ Thomas J. McGuire Lambertville, N. J. 283
WRBC Imanuel Lutheran Church Valparaiso, Ind. 278	WTG Kansas State Agricultural College Manhattan, Kans. 273
WRD Radio Corporation of America Washington, D. C. 468	WWAB Sanger Bros. Waco, Texas 260
WRK Doron Bros. Electric Co. Hamilton, Ohio 360	WWAC Wright & Wright (Inc.) Philadelphia, Pa. 360
WRL Union College Schenectady, N. Y. 360	WWAE Alamo Dance Hall, L. J. Crowley Joliet, Ill. 227
WRM University of Illinois Urbana, Ill. 360	WWAF Galvin Radio Supply Co. Camden, N. J. 230
WRP City of Dallas (police and fire signal department) Dallas, Texas 244	WWAO Michigan College of Mines Houghton, Mich. 244
WRW Tarrytown Radio Research Laboratory (Koenig Bros.) Tarrytown, N. Y. 273	WWI Ford Motor Co. Dearborn, Mich. 273
WSAB Southeast Missouri State Teachers College Cape Girardeau, Mo. 360	WWL Detroit News (Evening News Assn.) Detroit, Mich. 517
WSAC Clemson Agricultural College Clemson College, S. C. 360	WYAL Loyola University New Orleans, La. 260
	WYAM Electrical Equipment Co. Miami, Fla. 283
	WYAW Catholic University Washington, D. C. 236

## Canadian Stations

CFAC Calgary Herald Calgary, Alberta 430	CHCE Western Canada Radio Sup. (Ltd.) Victoria, B. C. 400
CFCA Star Pub. & Prtg. Co. Toronto, Ontario 400	CHCL Vancouver Merchants Exchange Vancouver, B. C. 440
CFCH Marconi Wireless Teleg. Co. of Canada Montreal, Quebec 440	CHYC Northern Electric Co. Montreal, Quebec 410
CFCL Abitibi Power & Paper Co. Ironsides Falls, Ont. 400	CJCA Edmonton Journal Edmonton, Alberta 450
CFCL La Cie de L'Evenement Quebec, Quebec 410	CJGC London Free Press Prtg. Co. London, Ont. 430
CFCK Radio Supply Co. Edmonton, Alberta 410	CJCD T. Eaton Co. Toronto, Ont. 410
CFCL Centennial Methodist Church Victoria, British Col. 400	CJCE Sprout-Shaw Radio Co. Vancouver, B. C. 420
CFCN W. W. Grant Radio (Ltd.) Calgary, Alberta 440	CJCI Maritime Radio Corp. St. John, New Brunswick 400
CFCO Semembaack-Dickson (Ltd.) Bellevue, Quebec 450	CJCN Simons Agnew & Co. Toronto, Ont. 410
CFCO Radio Specialties (Ltd.) Vancouver, B. C. 450	CJCS Percival Wesley Shackleton Olds, Alberta 400
CFCR Laurende Air Service Sudbury, Ont. 410	CJSC Evening Telegram Toronto, Ont. 430
CFCW The Radio Shop London, Ont. 420	CKAC La Presse Pub. Co. Montreal, Quebec 430
CFDC Sparks Co. Nanaimo, B. C. 430	CKCD Vancouver Daily Province Vancouver, B. C. 410
CFQC The Electric Shop (Ltd.) Saskatoon, Saskatchewan 400	CKCE Canadian Independ. Telephone Co. Toronto, Ont. 450
CFRC Queens University Kingston, Ontario 450	CKCH Canadian National Railways Ottawa 435
CFUC University of Montreal Montreal, Quebec 400	CKCK Leader Pub. Co. Regina, Saskatchewan 420
CHAC Radio Engineers Halifax, Nova Scotia 400	CKOC Wentworth Radio Supply Co. Hamilton, Ont. 410
CHBC Aberdeen Publishing Co. Calgary, Alberta 410	CKY Manitoba Telephone System Winnipeg, Manitoba 450
CHCD Canadian Wireless & Elec. Co. Quebec, Quebec 410	

## Cuban Stations

PWX Cuban Telephone Co. Habana 400	2HS Julio Power Habana 180
2DW Pedro Zayas Habana 300	2OL Oscar Collado Habana 290
2AB Alberto S. de Bustamante Habana 240	2WW Amadeo Saenz Habana 210
20K Mario Garcia Velez Habana 360	SEV Leopoldo V. Figueroa Colon 360
2BY Frederick W. Borton Habana 260	6KW Frank H. Jones Ft. Huachuca 340
2CX Frederick W. Borton Habana 320	6KJ Frank H. Jones Ft. Huachuca 275
2EV Westinghouse Elec. Co. Habana 220	6CX Antonio T. Figueroa Cienfuegos 170
2TW Roberto E. Ramirez Habana 230	6DW Eduardo Terry Cienfuegos 225
2HC Heraldo de Cuba Habana 275	6BY Jose Ganduxa Cienfuegos 300
2LC Luis Casas Habana 250	6AZ Valentin Ullivarri Cienfuegos 200
2KD E. Sanchez de Fuentes Habana 350	8AJ Alfrede Brocks Stgo. de Cuba 240
2MN Fausto Simon Habana 270	8BY Alberto Ravelo Stgo. de Cuba 250
2MG Manuel G. Salas Habana 280	8FU Andres Vinnat Stgo. de Cuba 225
2JD Raul Perez Falcon Habana 150	8DW Pedro C. Anduz Stgo. de Cuba 275
2KP Alvara Daza Habana 200	8EV Eduardo Mateos Stgo. de Cuba 180

### Big Test Station Planned

A new experimental radio station for a more complete investigation of radio phenomena and broadcasting will be opened within the next few months by the General Electric Company, at an estimated cost of \$150,000.

The station will be built on land recently acquired by the company in Schenectady, N. Y. A power house capable of delivering high power at various frequencies will be erected. The antenna structures will allow a wide range of wave lengths, so that systematic investigation can be made of the advantages of various wave lengths in solving the various problems discovered daily in the radio field.

The General Electric Company decided to erect an experimental station because the space available in the power house and operating section of WGY, the big broadcasting station, is not sufficient to permit test work without interfering with the regular programs.

## A REAL RADIO BARGAIN!

Radio Age Annual, the best hookup book, and one year's subscription—\$3. If you want this double bargain sign the coupon and mail at once. Send price by check, currency or money order. If by check add five cents for exchange.

Radio Age, Inc.,  
500 North Dearborn Street  
Chicago

Gentlemen: Please send me by return mail your illustrated Radio Age Annual, containing more than 100 big pages of hookups and instructions and also send me Radio Age, The Magazine of the Hour, for one year. I enclose \$3. This will give me a one dollar book and a \$2.50 subscription at

a saving of fifty cents. Please start my subscription with the.....number

Name .....

Street Address.....

City.....

State.....

If book alone is desired, mark cross here  and enclose \$1.00. If subscription only, mark cross here  and enclose \$2.50.



**TOWER'S**

**TOWER'S Scientific**  
 WEIGHS ONLY 80Z  
 Perfect Tone Mates  
**\$2.95**  
 Plus a few cents postage



Buy a Headset you'll be proud of

**RADIO  
 TOWER'S  
 SCIENTIFIC  
 HEADSETS**  
 Money Back Guarantee

**OUR \$200,000.00 COMPANY STANDS SQUARELY BACK OF EVERY HEADSET**

**WORLD'S GREATEST HEADSET VALUE**

Formerly \$6.00, now \$2.95, with Notable Improvements

Longer Cord (full 5 feet), Stronger Magnets, Higher Resistance, Increase of Sensitivity, Perfect Tone Mates

EVERY SET TESTED BY LICENSED RADIO OPERATORS

*Send no money - Order on a Post-Card*

THE TOWER MFG. CO. : 98T BROOKLINE AVENUE, BOSTON, MASS.

**Scientific**

**"GOOD SOLDERING MEANS GOOD RECEPTION"**

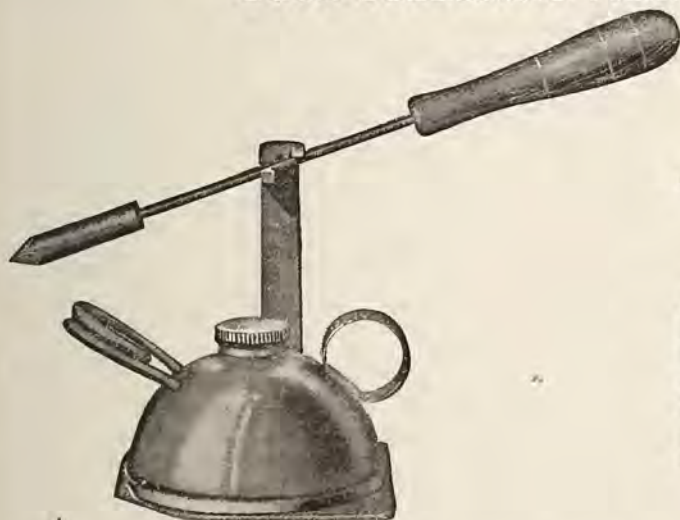

Patent Applied For

**Jiffy** Does the Work of a Torch *Twice Its Size* and *Three Times Its Price*

You can't get real results from high grade parts unless they are properly soldered. The Jiffy Blow Torch and Outfit will give you a red-hot job and last you a lifetime. The torch is self-blowing and develops an extreme heat of 2300 degrees F. under prio-electric tests. No parts to get out of order. Simply touch a match to the burner coil and the torch operates.

**IT CANNOT EXPLODE**

The Jiffy Torch and Soldering Outfit consists of Torch, Small Copper Soldering Iron, Metal Stand, Bottle of Non-corrosive Flux and String Solder.

**ASK YOUR DEALER FOR A DEMONSTRATION.**

**Price, \$2.50**

If your dealer can't supply you, send stamps, cash, money order, or sent C. O. D.

**Apex Stamping Co.**  
 Dept. AA, Riverdale, Ill.

# The Why of the Super-Heterodyne

(Continued from page 20.)

the neutrodyne it seems logical that similar increases in the ratios of heterodyne transformers would be attended with equally improved results. With higher ratios we would have greater grid potentials per stage and greater amplification for a given number of stages. Whether this would work out as well in practice as on paper remains to be seen.

## Regeneration

As ordinarily built in this country, the tuning circuit and first detector are of the simple non-regenerative type and therefore contribute little or nothing to the amplification. In the European versions, however, regeneration is generally used in the circuit of the first detector tube to gain increased range and amplification. This may be of the simple feed-back type with an adjustable tickler coil placed in inductive relation to the tuning inductance, or it may be of the "tuned plate" order in which a variometer is placed in the plate circuit of the first detector tube. The latter is the simplest and the more common method.

While the addition of regeneration by tickler or variometer does add considerably to the performance of the set, yet it has the objection of adding a third control. As the controls are fairly simple in the usual circuit (non-regenerative) this additional control is not a great objection when one becomes experienced in tuning the heterodyne, but still it is one more control just the same. Instead of having two controls we now have three, which in any event is no worse than with the neutrodyne.

It is likely that a simple regenerative circuit for the first tube (without regenerative controls) would be satisfactory, such as the common Colpitts type of "Ultra-Audion" or the "Wizard" described in the April issue of RADIO AGE. In such circuits, regeneration in the detector circuit is controlled largely by the rheostat adjustment and in a sense adds little to the complexity of tuning.

Regeneration in the first detector circuit must not be confused with the undesirable regeneration that we have taken so much pains to avoid in the radio frequency stages. It is desirable in the detector circuit, but must be avoided at all costs in the radio frequency circuit. Regeneration in the first detector circuit increases the output of the first detector tube and increases its sensitivity, thus giving the succeeding radio frequency amplifying stages stronger signals to work on. In the case of DX work this is a decided advantage. The great disadvantage is the fact that regeneration in the first detector circuit may cause re-radiation from the aerial and "pronounced squealing" when the tubes are allowed to oscillate, just as with an ordinary straight regenerative set.

It would seem that the signal strength could be still further increased by causing regeneration to take place in the circuit of the second detector tube, but to date

the writer has not seen any attempt at this method. This arrangement, of course, would not increase the range, but would only strengthen the signals of the waves passing through the radio frequency stages, and would probably act as an additional stage of audio amplification.

## Super-Regeneration

There have been a number of attempts at combining the super-regenerative circuit and the heterodyne, but so far not much real progress has been made. Instead of using the conventional non-regenerative circuit for the first detector tube, a super-regenerative circuit has been substituted, thus greatly increasing the sensitivity and signal strength of the conventional heterodyne. With a circuit of this type properly worked out we would have the maximum possible in radio reception, but this would be at the expense of control complication and tuning difficulties. The super-regenerative circuit is complicated and critical alone, but when operated in connection with a heterodyne the difficulties of tuning would make the circuit fit only for the expert operator.

## Audio Amplification

The heterodyne circuit proper ends at the second detector tube, where the amplified radio frequency waves are converted into audible sound frequency waves. If increased volume is then required for the operation of a loud speaker, we must add the usual audio amplification circuit on one or more stages. There is no marked difference in the audio amplification system from that ordinarily used with the simpler receivers, except that it is highly desirable to use an independent "B" battery for the audio stages, and when dry cell tubes are used in the set, even a separate "A" filament battery is highly desirable.

With a common "B" battery for both the radio and audio amplification stages there is likely to be much noise and distortion due to the harmonics and minor oscillations taking place in the first part of the circuit. These undesirable pulsations and "bumps" are carried directly into the audio frequency tubes through the common "B" battery wires unless a special filter circuit is interposed. With a separate "B" battery for the audio tubes, the bumps can only be carried in by induction and hence are not so noticeable. Direct wire connections of any sort between the heterodyne and audio stages should be eliminated whenever possible.

## Filter Circuits

In the most highly developed heterodyne circuits it is common practice to place a "filter" circuit between the second detector and the audio stages. This consists of a combination of high resistance units with condensers or choke coils which damp down undesirable pulsations that originate in the first stages before they pass to the audio stages. Such filters are highly de-

sirable and are comparatively simple and inexpensive accessories to the heterodyne circuit.

Every noise developed in the detectors and radio stages is, of course, amplified with the voice and music by the audio stages, and with two or more audio stages the foreign pulsations become almost unbearable unless they are removed or reduced by the filter system. The greater the audio amplification, the greater will be the necessity for an effective filter.

## Antenna Insulation

Good insulation is necessary and it recommends that the wire be swung over a clear space if possible, with at least five feet clearance over all objects crossed. Number 14 solid, bare, copper wire, or larger sizes, are recommended, since it has low resistance and results in loud signals. Stranded wire, though stronger, is not considered quite as good as solid wire. Insulated wire, he explained, is not especially detrimental, but costs more than bare wire. From 50 to 150 feet is the usual length recommended for broadcast reception; longer aerials bring in stronger signals, and are more certain to bring in distant stations. But they also bring in more interference, including static.

## For Women Buyers

The feminine influence is commencing to make itself felt in radio. One large manufacturer of loud speaker horns has received orders for thorite horns to be made in nine different pastel shades to harmonize with the color schemes of their owners. Dealers report that where a man will insist on purity of tone and volume from a loud speaker, the women buyers will devote just as much attention to the coloring and design of the outfit. Incidentally, the loud speaker industry is assuming tremendous proportions, 600,000 horns and 90,000 complete thorophone loud speakers being fixed as the 1924 production from one Chicago factory.

## Navy's Radio Progress

The navy recognized the value of radio in 1899, when Marconi came to New York with three radio sets to aid in reporting the yacht races between the Shamrock and the Columbia. Four naval officers observed the operation of the sets, and a short time later the Battleship Massachusetts, the Cruiser New York, and the Torpedo Boat Porter were placed at the disposal of Mr. Marconi and an experimental shore station was established at Highland Lights.

Today the navy's communication system represents an investment of \$15,000,000 and includes nine high-powered, long range stations, together with 71 medium and low powered stations, and 45 compass stations, operated by 70 officers and 1,167 men.

# CROSLEY

## Better-Cost Less Radio Products

\$65<sup>00</sup>



CROSLEY TRIRDYN 3R3



\$75<sup>00</sup>

CROSLEY TRIRDYN 3R3 SPECIAL



## WORLD LEADERS

**I**N EVERY field of endeavor there is always a champion—a man, a product or a thing that takes the leadership, not by accident, but because of actual merit. In the new industry of radio, a leader has already arisen—Crosley Radio Receivers.

There is nothing miraculous about the tremendous popularity of Crosley Instruments. They have taken their place at the top through proven performance, continually giving perfect satisfaction where, perhaps, radio disappointment had been purchased at a much higher price.

In new inventions, new simplified devices and new ways and means of giving greater radio value at a lower price, Crosley has constantly led. As a result, the purchaser of a Crosley Radio Receiver, knows that he is getting the last word in radio perfection.

This is evidenced by the fact that Crosley is building more radio receivers than any other manufacturer in the world.

Above are illustrated two good reasons for Crosley

supremacy—the Crosley Trirdyn 3R3 and Crosley Trirdyn 3R3 Special.

These instruments are the latest radio engineering triumphs—three tube sets giving five tube efficiency.

They contain the following attractive features: Tuned Radio Frequency Amplification, Regenerative Detector reflexed back on the first tube, and an additional stage of Audio Frequency Amplification.

They are non-radiating, thus entirely eliminating neighborhood interference. For ease of picking up new and distant stations, perfect calibration and extreme selectivity, the Trirdyn is unexcelled.

The only difference between the two models is in the size and style of the Cabinets. The Trirdyn 3R3 Special is completely self-containing, having places for the necessary dry batteries, head phones and other accessories.

Over 200 experts have thoroughly tested the Crosley Trirdyn. Their opinions are one and the same. "There is no receiver to compare with it at any price."

*Licensed under Armstrong Regenerative Patent No. 1,113,149.*

Before you buy see the Crosley line.

For sale by good dealers everywhere.

## THE CROSLEY RADIO CORPORATION

Powel Crosley, Jr., President

*Formerly The Precision Equipment Company and Crosley Manufacturing Company*

663 ALFRED STREET

CINCINNATI, OHIO

*Crosley owns and operates Broadcasting Station WLW.*

# I Can Qualify You as a Radio Expert in a Few Months!



**E. R. HAAS**  
Director, National  
Radio Institute.

## Learn at Home

## Earn \$2500 to \$10,000 a Year

Merle Wetzel, one of my students, reports that he is now making *three times* what he did before becoming a radio expert. Emmett Welch writes that after finishing my training, he made \$300 a month and all expenses. George Jones says: "To your course I credit my present position as manager of this Radio Department." Another graduate is now an operator of a broadcasting station, PWX of Havana, Cuba, and earns \$250 a

month. Still another graduate, only 16 years old, is averaging \$70 a week in a radio store. Hundreds of other former students enthusiastically tell of their successes as radio experts! The field of Radio today is a real treasure house of wonderful opportunities. It offers rewards beyond your fondest dreams! Mail coupon today for my Free Book just out—which explains in detail the amazing opportunities in this World's Fastest-Growing Industry.

## Hundreds of Big Paying Positions Waiting

Do you want to earn far more money than you ever dreamed possible? Do you want to be your own boss?—to have a profitable business of your own? Do you want to travel the whole world over—and make big money while doing so?

Radio offers you all of these opportunities—and more! Radio, the new infant industry; Radio, growing with leaps and bounds; Radio, the field of endeavor with the most promising future of all!

Hardly a week goes by without our receiving urgent calls for our graduates. "We need the services of a competent Radio Engineer"—"We want men with executive ability in addition to radio knowledge to become our local managers"—"We require the services of several resident demonstrators"—these are just a few small indications of the great variety of opportunities open to our graduates.

### This Wonderful FREE BOOK Has Shown Thousands the Way to Bigger Money

This Free Book has opened the eyes of thousands to the glorious opportunities in Radio. Never in all history has an industry jumped into prominence so rapidly! Millions of dollars now spent yearly on Radio. Hundreds of big money positions have been created almost overnight. Thousands of men trained in Radio are needed. If you are ambitious—if you are looking for a field which offers *big money, fascinating work, advancement, and a real future*, send for this Free Book. It costs you nothing. You oblige yourself in no way. Yet this book can easily mean all the difference between the

work you are doing now and wonderful success! Before you forget—mail the coupon NOW!

**National Radio Institute**  
Dept. 53-FA, Washington, D. C.



**1000 Mile Radio Set  
FREE**



In order to complete your practical instruction at home, learning by actual experience, this splendid regenerative receiving set is now included in addition to material for building latest up to date receiving sets.

Fresno Reg. Licensed  
Armstrong U. S. Patent  
No. 1113149.

**E. R. HAAS,**  
**NATIONAL RADIO INSTITUTE,**  
Dept. 53FA, Washington, D. C.

Without obligation on my part, please send me the free book "Rich Rewards in Radio", with full details as to how I can quickly train for the position of "Certified Radio-trician" in my spare hours at home. Also tell me how your free Employment Service will help me secure a good paying position, and about your special short-time offer. *Please write plainly.*

Name.....  
Street.....  
City..... State.....

# Scanned from the collections of The Library of Congress



Packard Campus  
for Audio Visual Conservation  
[www.loc.gov/avconservation](http://www.loc.gov/avconservation)

Motion Picture and Television Reading Room  
[www.loc.gov/rr/mopic](http://www.loc.gov/rr/mopic)

Recorded Sound Reference Center  
[www.loc.gov/rr/record](http://www.loc.gov/rr/record)

**This file including all text and images are from scans of a private personal collection and have been scanned for archival and research purposes. This file may be freely distributed, but not sold on ebay or on any commercial sites, catalogs, booths or kiosks, either as reprints or by electronic methods. This file may be downloaded without charge from the Radio Researchers Group website at <http://www.otrr.org/>**

**Please help in the preservation of old time radio by supporting legitimate organizations who strive to preserve and restore the programs and related information.**