

Smallest Regenerative Set in World—Flewelling

Radio Digest

EVERY
WEEK

Illustrated

TEN
CENTS

REG. U. S. PAT. OFF.

Vol. V

Copyright, 1923
R. D. P. Co. Inc.

SATURDAY, JUNE 23, 1923

No. 11

RADIO PHOTOSCULPTURE

FOUR GIANT PLANTS LINKED FIRST TIME

BROADCASTS PUT ON AIR
SIMULTANEOUSLY

WEAF, WGY, KDKA, and KYW,
Widely Separated, Join
in Experiment

NEW YORK, N. Y.—For the first time in history, four big stations in various parts of the country were linked together and broadcast simultaneously recently when the program of the National Electric Light Association convention here was put on the air by WEAF, WGY, KDKA and KYW. The stations were linked with microphones in the hall by telephone lines.

The speaker at the evening meeting was Julius K. Barnes, president of the United States Chamber of Commerce, and Anna Case, Metropolitan Grand Opera star, sang.

The engineers who worked on the installation of the lines encountered a serious problem in preparing telephone lines suitable to the handling of high frequency currents. Each of the lines had to be carefully balanced and equalized by means of special networks and other adjusting instruments.

Hear Anna Case at Home

When Anna Case sang her voice was heard by a vast assemblage on the common and in the streets of Flemington, N. J., the century-old town near which the singer spent her early girlhood days.

This was accomplished by means of a mobile public address system which a citizens' committee arranged to bring to the historic county seat of Hunterdon County for the occasion.

A receiver operated by engineers picked up Miss Case's voice, and transmitted it to a big vacuum tube voice amplifier which made her voice audible in even the farthest corners of the park and along the tree-lined streets.



SCULPTOR NO LONGER NEED SEE SUBJECT

Carving by Ether Waves Made
Possible by Radio Photo
Transmission

British-Yank Invention

Line Charts of Pose Are Flashed
Through Air to Artist Many
Miles Distant

By Fred Claire Zumbro

First, pictures by Radio and now "Radiosculpture"! This remarkable accomplishment is brought about through the inventions of H. M. Edmunds and C. Francis Jenkins. By combining the inventions of these two men it is possible to carve a perfect likeness of a person thousands of miles away. Not a slight artistic likeness is the result, but a mechanically perfect model that will measure correct to the thousandth of an inch.

It is now made possible for a person on shipboard of a trans-Atlantic liner to sit for a few seconds before a camera and be able to call at the studio ashore, upon arrival, and see his own likeness carved in stone, marble or granite cast in bronze. The process requires from two to three days at the most for completion, after the

(Continued on page 2)

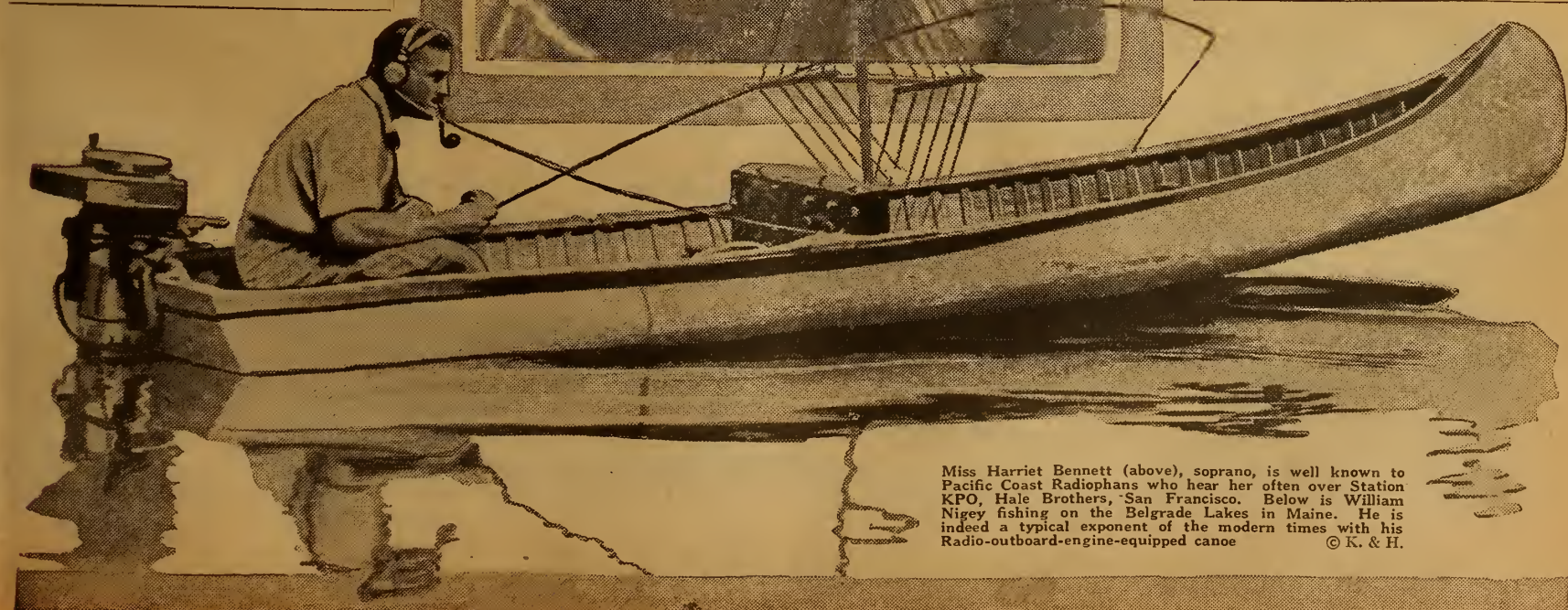

Miss Harriet Bennett (above), soprano, is well known to Pacific Coast Radiophans who hear her often over Station KPO, Hale Brothers, San Francisco. Below is William Nigey fishing on the Belgrade Lakes in Maine. He is indeed a typical exponent of the modern times with his Radio-outboard-engine-equipped canoe © K. & H.

DIGEST FANS SEND IN OFFER COUPONS

TO GET VALUABLE STANDARD PARTS FOR SETS

More Items Added to List—Readers Endorse Simplicity of Special Offer Idea

SPECIAL REWARD OFFER Coupon Number 4

This Special Reward Coupon appears each issue in Radio Digest until further notice. When sent in, accompanied by necessary remittance, according to the rules governing same, apparatus can be secured. See apparatus list and rules of offer below.

Save Me—I Am Valuable

Readers of the Digest all over the country are beginning to send in their Special Reward Offer Coupons. Although only three of the coupons have been printed so far, many letters have flooded in containing two consecutive coupons and remittance for various of the items listed below under Class A. Other Radiophans have told their intentions of saving the offer coupons for more expensive apparatus, listed in Class E or above.

A number of new items have been added this week to the very complete list of apparatus already catalogued. Among these are Turney spider web coils and mount, Premier variable condensers and audio frequency transformers, Delta Midget tubes with sockets and adapters, and Resistometers.

The simplicity of the method of getting the many standard and valuable parts and accessories for sets, in practically every case has appealed to the enthusiastic readers. All that is necessary is to clip the consecutive coupons appearing weekly on page two, and send them, accompanied by the necessary remittance for the selected item, to the Digest. There is no limit to the number of coupon series that can be sent in by an individual for apparatus.

Rules to Remember

One point must be emphasized to those contemplating taking advantage of the special offer; that is, that the coupons turned in for any item must be numbered consecutively, as for example, 1, 2, 3, and 4 or 3, 4, 5 and 6. The number of coupons necessary and the cash remittance, of course, depend on the item sought by the reader. There is no limit to the number of series turned in by any one reader.

Another point to remember is that cash, checks and money orders but no postage stamps will be accepted.

To make selection more simple the items have been divided into eight classes, each class depending on the number of consecutive coupons and amount of cash remittance necessary. The eight classes of items follow:

Class A Articles

For two consecutively numbered coupons and thirty cents (\$0.30) any one of the following articles will be sent: 1 Carter Imp Jack and Plug; 1 Carter 15-ohm Resistance Unit; 1 Schindler .00025 mfd. Build-up Mica Condenser; 1 Schindler .0005 mfd. Build-up Mica Condenser; 1 Schindler .001 mfd. Build-Up Mica Condenser; 1 Schindler .002 mfd. Build-Up Mica Condenser; 1 Schindler .0025 mfd. Build-Up Mica Condenser; 1 Martin-Copeland Sta. Put Plug; Walnut Standard Tube Socket; Walnut UV-199 Socket; Ray-O-Yac Dry Battery, 1 1/2 volts; Dubilier Micadons Type 601 (.0001, .00025, .0005, .001, .002, .0025, .003 or .004 mfd.); Premier Grid Condenser (.00025 or .0005 mfd.); Premier Variable Resistance; 1 Carter 25-ohm Resistance Unit; Standard Socket Adapter for Delta Midget Tube.

Class B Articles

For four consecutively numbered coupons and sixty cents (\$0.60) any one of the following articles will be sent: 1 Carter .04 mfd. Special Fixed Condenser; 1 Carter Jack Switch; 1 Carter Hold-Tite Jack, One Spring Open Circuit; 1 Carter Hold-Tite Jack, Two Spring Closed Circuit; 1 Carter Hold-Tite Jack, Three Spring Filament Control; 1 Carter Hold-Tite Jack, Four Spring Closed Circuit; 1 Carter Hold-Tite Jack, Five Spring Filament Control; 1 Pudin Variable Grid Leak with .00025 mfd. Condenser; 1 Federal Universal Phone Plug; 1 Federal Open Circuit Jack; 1 Federal Closed Circuit Jack; 1 Federal Double Circuit Jack; 1 Martin-Copeland Shur Grip Plug; 1 Martin-Copeland WD-11 Socket; 1 Martin-Copeland WD-11 Adapter; 1 Martin-Copeland UV-199 Socket; 1 Martin-Copeland UV-199 Adapter 1 Martin-Copeland Pull Switch; 1 Martin-Copeland 5-point Inductance Switch; 1 Martin-Copeland Variable Grid Leak; 1 Martin-Copeland SPST Knife Switch 1 Martin-Copeland SPDT Knife Switch; 1 Martin-Copeland DPST Knife Switch; 1 Martin-Copeland DPDT Knife Switch; Walnut Variable Grid Leak; Walnut Inductance Switch; Electrad Grid Leak (with clip mountings); Dubilier Micadons Type 600 (.0001, .00025, .001, .002, .0025, .003, .004, or .005 mfd.); Dubilier Micadons Type 610 (.001, .002, .0025, .003, .004, or .005 mfd.); Dubilier Micadons Type 601 (.001, .002, .0025, .003 or .004 mfd.); Dubilier By-Laws Condenser (.1, .25, or 5 mfd.); Premier Universal Tube Socket; Premier Radio Dial (3/16, 1/4, or 5/16 inch black or white face); Premier Universal Radio Jack, Open Circuit; Premier Universal Radio Jack, Two-Circuit Three Spring; Premier Universal Radio Jack, Two-Circuit Four Spring; Premier Universal Radio Jack, Filament Control Three Spring; Premier Switch Lever and 10 Points; Turney Spider Web Coil (SW-20 with .038 milhenry inductance, SW-15 with .066 MH., or SW-20 with .300 MH.)

Class C Articles

For six consecutively numbered coupons and ninety cents (\$0.90) any one of the following articles will be sent: 1 Carter 6-ohm Vernier Control Rheostat; 1 Carter "Tu-Way" Plug; 1 Federal Panel Mount Socket; 1 Federal 6-ohm Rheostat; 1 Federal 3-ohm (Power) Rheostat; 1 Amperite Automatic Filament Control (with mounting); 1 Martin-Copeland Marco Rheostat; 1 Martin-Copeland Series Parallel Switch; 1 Martin-Copeland DPDT Panel Switch; 1 Martin-Copeland 7-Point Inductance Switch; 1 Martin-Copeland 9-Point Inductance Switch.

AN EVENING AT HOME WITH THE LISTENER IN (SEE NOTE BELOW FOR INSTRUCTIONS)

Table with columns: Station and City, Met., Monday, Tuesday, Wednesday, Thursday, Friday, Saturday, Sunday. Lists broadcast times for various stations like CFCA, CFCN, CKAC, etc.

Instructions for Use.—All the hours above are given in Central Standard Time. If your city uses Eastern Time, add one hour to each of the periods stated; if your city uses Mountain Time, subtract one hour; if your city uses Pacific Time, subtract two hours. If in addition your city is using Daylight Saving Time, add one hour to this result.

CONTENTS

Radio Digest, Illustrated, Volume V, Number 11, published Chicago, Illinois, June 23, 1923. Published weekly by Radio Digest Publishing Company, 123 West Madison Street, Chicago, Illinois. Subscription rates, yearly, Five Dollars; Foreign, Six Dollars; single copies, Ten Cents. Entered as second-class matter at the postoffice at Chicago, Illinois, under the Act of March 3, 1879.

Table listing contents: "All the Live News of Radio" (1 to 6), World's Smallest Regenerative Set (2), The Week's Advance Broadcast Programs (5), Broadcasting Station Directory (7), Flewelling Answers (9), Editorials (10), First Steps for Beginners in Radio (11), Flewelling Circuit in Portable Set (12), How to Make a Camper's Portable Reflex Set (13), Selectivity in Portable R.D.-86 (14), Questions and Answers (15), Radio Illustrated, a Page of Pictures (16).

Looking Ahead

For the Campers, Bathes, Automobilers, Hikers—and who not? Harry J. Marx will continue next issue to tell how to build a portable set complete in a fiber carrying case. Read page thirteen. Batteries, headset, and even a loop aerial are compactly assembled in a convenient unit. In the June 30 issue Mr. Marx will give three good hook-ups from which the builder may choose.

Beginners' First Steps by Thomas W. Benson next week will be devoted to the theory and operation of the vacuum tube as a detector. Mr. Benson's review of this important fundamental in the foundation of Radio knowledge, should be read even by the experienced amateur.

A Super of the Latest Type—The Nacireman—Complete hook-up diagram showing its wiring connections and parts. Many excellent reports have been given on this circuit. Watch for it next week as R.D.-87.

Flewelling Answers to Radiophans' Queries—a department for the Flivver Super fans. E. T. Flewelling continues to write exclusively for the Digest, while he prepares to spring a few more big surprises. Keep your eye on Flewelling!

A Radio Baseball Schedule—for the Ball-Radiophan. This schedule will appear in an early issue and will tell what big stations are giving baseball results and what games are broadcast. Tell your baseball fan friend about it.

Have a Copy with You on Your Vacation

SEND IN THE BLANK TODAY

Radio Digest

YOU WANT IT!

BE SURE OF YOUR WEEKLY COPY BY SUBSCRIBING NOW

Publisher Radio Digest, 123 West Madison St., Chicago, Illinois.

Please find enclosed check M. O. for Five Dollars (Six, Foreign) for One Year's Subscription to Radio Digest, Illustrated.

Name

Address

City..... State.....

RADIO PHOTOSCULPTURE

(Continued from page 1)

impressions have been transmitted by Radio, which in itself requires about one hour.

Develops From Photosculpture

H. M. Edmunds of Brighton, England, has given to the world "photosculpture" or "cameraography," after many years study and tireless work. This process is brought about by photographing the person or model to be graven and then chiseling by a delicate machine, from the photo-impressions.

First the subject is placed before two cameras, set at an angle so that the two planes formed by the exposed part of the plates in each camera give a two plane view of a three plane object, (the model). That is, the third, or front plane actually overlaps into each of the other or side, two. This simpler form is described for convenience. When more than a side view portrait is wanted, or it is desired to produce a statue, three or more cameras are used set in a circle around the model.

Example of Side View Portrait

For clearness only the side view portrait will be taken for an example of how "Radiosculpture" is accomplished.

With the two cameras set at an angle and focused on the model, a projector, similar to a slide machine used in motion picture theaters, is set between the two cameras and directly in front of the model. A ground glass slide engraved with vertical parallel lines, about 150 to the inch is placed in the machine and the shadow of the lines thrown upon the model to be sculptured.

These lines will appear warped and distorted when viewed from any point other than that occupied by the projector. It is upon this illusion that this step of the operation is based. The two cameras are set at an angle so as to obtain an impression of the contour of the lines as they fall and rise with the surface covered.

When the plates are developed and the pictures printed the result is a photograph of the model entirely covered with fine lines that accent the curvature of the surface covered. These are the charts for modeling the actual portrait.

So far only Mr. Edmund's invention has been considered, but at this point the equally wonderful invention of Mr. Jenkins overlaps his co-worker's. By Radiophotography the plates, or charts, are sent to where the actual work of sculpturing is to be done.

How Charts Are Sent by Radio

The process of sending these sculpturing charts by Radio is even more simple in operation than sending a photograph. First the model is outlined by an artist, then only the outline and the lines, thrown by the projector, are transmitted. By this method only two tones, black and white, are transmitted whereas in sending an ordinary photograph it is necessary to deal with the series of gray tones ranging from black to white.

The charts are placed in the Radiophoto transmitter which theoretically cuts the photo into small slices. That is, a tiny mirror follows up and down, beginning with one edge, and traveling in a series of parallel lines that slightly overlap the adjacent ones. The impressions of the light and dark on the mirror reflect into a selenium cell that conveys the impression received into the actual Radio transmitter where the impressions are again transformed, this time into ether waves. The receiving mechanism reverses the process on a sensitized medium, such as photo print paper.

How Ingenious Apparatus Works

When the cutting, or modeling charts have been received the process reverts back to the invention of Mr. Edmunds. The charts are then placed in a delicate drilling machine. This guided by the hand of the operator, drills in tiny furrows in a series of parallel lines. These small trenches are varied in depth to conform with the rise and fall of the lines on the Radio transmitted chart. If a bold relief is wanted the drill is driven deeper into the material used than if a plaque is being made.

The furrows are so small and so closely drilled that it is almost impossible to see the ridge between with even the aid of a high powered microscope. To the naked eye the finished product appears even more delicately carved than handwork, work that requires weeks and even months to complete with the model constantly before the sculptor in a fatiguing pose.

Possible Uses of Invention

In the future when a great person of note leaves a foreign land to visit another country it will be possible for him to view his own carved likeness produced in the land of visit. This can be done by Radiosculpture without the sculpturer even seeing his model.

By Radiosculpture it will be possible to preserve the drilling charts for future generations to erect statues of memorial or commemoration.

Relief maps in time of war, may also be rapidly duplicated at distant points where needed.

Another valuable aid of Radiosculpture is that of transmitting architectural models from one city or country to another. No longer will an architect have to rely on drawings to impress a builder. It means a builder will be able to see an actual model of a building or statue submitted by an architect or sculpturer thousands of miles away.

INVISIBLE AUDIENCE HONORS ITS CHURCH

KDKA'S AIR CONGREGATION ERECTS BRONZE TABLET

Contributions Reach 4,700 for Memorial to First Chapel to Have Services Broadcast

PITTSBURGH.—The first Radio memorial tablet in the world—donated by and dedicated to the invisible Radio congregation of Calvary Episcopal Church, Pittsburgh, Pa.—was unveiled during the church services of that congregation recently.

Hundreds of men, women and children witnessed the dedication of the bronze tablet to the unseen Radio congregation which is known to be in the area stretching from the Atlantic to the Pacific ocean and from Hudson Bay in the north of Canada to the extreme southern part of South America and which was enlisted when KDKA, one of the pioneer Radiophone broadcasting stations, began to broadcast Calvary Church's services more than two years ago.

First Radio Minister Present

Rev. Edwin J. van Etten, pastor of the church, who was the first minister in the world to have his services broadcast; Bishop Alexander Mann, of the Pittsburgh Episcopal diocese; H. P. Davis, representing Station KDKA of the Westinghouse Company, which station first broadcast church services, and other prominent Pittsburghers took part in the ceremony.

More than 4,700 people contributed to the purchase of the tablet. The contributions came in every form of legal tender—silver dimes, stamps, nickles, pennies and checks. A worker in a southern cotton mill sent Dr. van Etten two cotton socks with a nickel in each toe. A sailor from a boat on the Atlantic sent the minister 120 pennies he had won playing penny ante.

Listeners Respond Quickly

The contributions came as a result of Rev. van Etten's idea that his Radio congregation to which he had been preaching since January 2, 1921, might like to contribute to some sort of memorial. Accordingly during the reading of his regular announcement Dr. van Etten addressed, directly, his unseen hearers and told them of the plan and asked small contributions from such of them as might like to participate.

Responses to the idea were almost instantaneous. An hour after the announcement was broadcasted contributions were received from people living in Pittsburgh. People living in the district even walked to the minister's home a few minutes after they had listened in to him and left their contributions, even as he was preaching by Radio.

Calgary Signals Heard Off Japanese Coastline

5,000-Mile Transmission Sets New Canadian Record

CALGARY, ALTA.—What constitutes a record for long distance Radiophone broadcasting in Canada was established by CFCN, the broadcasting station of the W. W. Grant Radio, Ltd., here recently, when it was heard off the coast of Japan, which is approximately 5,000 miles from Calgary, and in another hemisphere.

CFCN signals were heard by L. S. Haire, Radio operator on board the steamship Stuart Dollar, plying between San Francisco and the Orient, when the ship was just out of Yokohama, according to a communication received from Mr. Haire.

Actress in Flag Day Address

NEW YORK.—One of America's most distinguished actresses, Julia Arthur, gave a patriotic recitation, "The Flag," on Flag Day, before Station WEAF's microphone. Miss Arthur is one of America's favorites and gave much of her time during the war to patriotic service.

DEMPSEY MATCH ON CFCN—EVERY PUNCH

CALGARY, ALTA.—The Gibbons-Dempsey world heavyweight championship match at Shelby, Montana, will be broadcast July 4 from Station CFCN of Calgary, owned by W. W. Grant, Ltd. A direct wire will run from the ringside to the powerful station. This plant is the nearest super station in the vicinity and has a working range of over 1,000 miles.

"AL" SMITH CHOOSES AIR AGAINST PRESS

ALBANY, N. Y.—By wire from Albany to Station WGY, Schenectady, Governor Alfred E. Smith reached the ear and mind of the citizens of New York state recently when he gave a report of his stewardship. The report generally reaches the voters through the press. This year Governor Smith talked direct to the people, explaining the financial condition of the state in detail.

MAKES CYCLE RIDING EASIER



Why shouldn't it be easier to ride a bicycle equipped with a portable set. (Note, the spokes should make a good antenna.) After balancing some regenerative sets it should be less difficult to keep one's balance on a cycle. At least Miss Josephine Kiernan thinks the plan worth smiling about © K. & H.

ARMY-NAVY CONCERTS TO BE SENT OVER U.S.

New Washington Plant to Relieve NAA During Summer

WASHINGTON.—Although the broadcasting of the government's band concerts by NAA, Arlington, will cease during the summer months, Radiophans within several hundred miles of Washington will be able to pick up some of the concerts if the plans of the Chesapeake and Potomac Telephone Company are carried out. By June 18, this company hopes to complete its new station here and start

broadcasting the open air public concerts from the White Lot and local parks where the Marine, Navy and Army Bands play almost daily.

Through the aid of a new portable input apparatus recently perfected by the telephone engineers, the company expects to furnish the added electricity necessary to pick up concerts and transmit them by wire to their station for broadcasting. This apparatus is mounted on a motor truck and can be dispatched anywhere in the city where something is to be broadcast.

Important speeches and some of the concerts will be put on a land line to New York and broadcast simultaneously from Station WEAF on a different wave length, it is planned.

RADIOS TREATMENT TO INJURED SAILOR

SEA-AMBULANCE ANSWERS EMERGENCY APPEAL

Vessel Anchored Nine Miles from Land Brings Help by Ether Waves

By L. M. Lamm

WASHINGTON, D. C.—The steamship West Cahous, lying at anchor in Baltimore harbor, nine miles from the city, needed medical help at about 3 A. M. recently and needed it quickly. A member of the crew had fallen into the hold and hurt himself seriously. So the captain of the ship sent a Radio broadcast asking help.

The call was picked up, not in Baltimore, nine miles away, but at Cape May, N. J., about 100 miles due east of Baltimore. As Cape May was separated from the West Cahous by parts of New Jersey and Delaware and by the eastern shore of Maryland, not to mention Delaware and Chesapeake Bays, no direct help from it was possible.

Operator Consults Surgeon

But the operator was on the job. Promptly he consulted the long distance list in the Baltimore telephone directly and called up the residence of the Public Health Service, surgeon in charge of the Marine Hospital in Baltimore, 100 miles to the west. The surgeon, roused from sleep to receive the message, asked him to Radio certain emergency treatment to the West Cahous and to direct the captain to send a boat to a certain pier in Baltimore, where he would find a surgeon waiting to go out to the ship with him. And so, in the middle of the night, in less than an hour, a "Radio-controlled," seagoing ambulance carrying a Public Health Service officer reached the side of the injured sailor and brought him later to the hospital.

PRIVATE PLANTS TO TAKE LAKE STATIONS

Step Necessitated When Navy Quits Nine Plants

CHICAGO.—Radio service will be provided for great lakes shipping as the result of a recent agreement of private broadcasters to handle great lakes traffic. R. H. C. Mathews, Station 9ZN, divisional superintendent of the American Radio Relay league, working in co-operation with Station WJAZ, will handle the "code stuff" for this territory. The necessity of getting a private broadcaster to handle the lakes traffic was caused by the navy's withdrawal from nine great lakes stations.

In Cleveland, according to an Associated Press report, the Great Lakes Wireless association was organized by vesselsman having boats equipped with Radio. Through this organization, which is headed by Fred L. Leckie, of Cleveland, the navy station at Duluth will be operated by the association and negotiations are reported for the association to take over eight other navy stations.

Vermont "U" Plant May Be Link in Army Relay

Star Student Station Drafted to Co-operate Officially

BURLINGTON, VT.—Owing to their activity and successful work of the past two years, the University of Vermont Radio station, 1ARY, has been selected to go through several tests in preparation for co-operating with the army Radio station at Ft. Ethan Allen in receiving and relaying government messages. The station at the university is under the management and operation of the students, and, has been heard regularly in England this spring. Two years ago this station was one of the first to be heard in the amateur transatlantic tests to Scotland.

THE ANTENNA BROTHERS

Spir L. and Lew P.

Undesirable Outside Interference

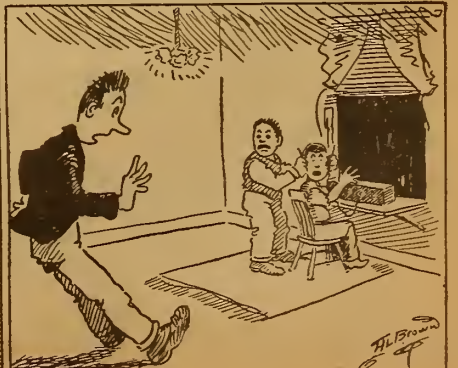
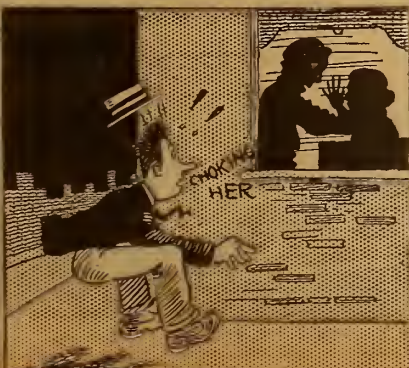

HEAR FALSE TINKLE OF LIQUOR GLASSES

CANADA PROGRAMS RAISE AWFUL THIRST IN U. S.

Alberta, However, Shatters All Illusions in States—She's Dry Herself! —But She Votes Again

By Jeffrey J. Dingman

CALGARY, ALTA.—Radio is playing a tremendous part in increasing to an almost unendurable stage the thirst of American Radiophans, rendered already severely acute by the Volstead act and ardent prohibition enforcement agents.

Recent broadcasts from CFCN, the station of the W. W. Grant Radio, Ltd., here, have added greatly to the thirst of that part of the American nation which nightly clamps the headset on and tunes in its receiving set to Canadian stations. For, wafted on the ether waves out of Canada come vague hints and aggravating rumors of flowing wine and liquor to be obtained just by crossing the border.

Evidently Radiophans of the United States are suffering from an illusion, for there is just as total prohibition of alcoholic liquors in Alberta at the present time as there is in the United States. However, the people of Alberta are again to vote on the liquor question November 5 and Radiophans of Canada's sister nation across the international line are already making preparations to have their receiving sets in perfect order for that night to hear the big news broadcast from CFCN at Calgary.

Cabaret Broadcast Starts Something
Ever since jazz music from the Plaza Cabaret in Calgary has been broadcast by remote control from CFCN, a flood of letters with the words "prohibition," "liquor," "dry," and the remainder of the well-known vocabulary, has been pouring into the broadcasting station.

In repudiation of rumors to this effect which apparently have become exceedingly common in the United States, it may be stated that absolutely no intoxicating liquors are allowed on the premises of the Plaza cabaret, and only the imaginations of the listeners in are responsible for the false impression which has been gained.

Business men of Calgary report that this feature, recently commenced by CFCN would be a considerable factor in attracting a great many tourists from the United States to Canada this year.

Veteran Humorists Put on Army Program at WCAH

COLUMBUS, OHIO.—La Societe des Hommes et 8 Chevaux, the fun organization of the American Legion, broadcast a program recently through Station WCAH, the Entekin company. The Columbus branch of the order, Am Le Vulture No. 15, made its Radio debut on this occasion, and presented music and humor redolent of life in the army and navy, featuring bugle calls so familiar to the wearers of the olive drab.

Form Radio Club in Berlin

WASHINGTON, D. C.—A Radio club has been founded in Berlin by a number of experts and amateurs for the purpose of furthering the interests of amateur Radio operators and of bringing general Radio matters to the attention of the authorities.

SUMMER PHOTOGRAPHS? EARN A DOLLAR—

SUMMERTIME means summer pictures. You and your camera can earn a dollar by sending the Digest out-of-door photos involving the use of Radio in camp, the automobile, swimming, boating, canoeing, on the hike, playing golf, etc. Send such photographs with negatives and a few descriptive words, including a stamped, addressed envelope so that unsuitable pictures may be returned.

SUMMER PHOTO DEPARTMENT,
Radio Digest,
123 W. Madison St., Chicago.

RADIO FIRE ALARM SYSTEM FOR BOSTON

City Soon to Have Airphone School for Laddies

BOSTON, MASS.—Although Radio has had an unofficial status in the Boston fire department for some time, most of the firehouses having receiving sets to get the broadcasts and while away the time during hours between alarms, the department is soon to have a school of Radio instruction.

Commissioner Theodore A. Glynn has ordered that such a school be established at once with George A. Fickett, superintendent of fire alarms in charge, and twenty men under instruction at present. When the course is completed, the men of the school will man the Radio fire alarm equipment which will augment the regular signal system, and eventually perhaps, supersede the wire system in directing movements of the fireboats at East Boston and South Boston, which now have Radio equipment.

Copy Navy Code 11,500 Miles

WASHINGTON.—A Radiogram from the naval station at Caviet, P. I., addressed to San Francisco for relay to Washington, was picked up in the Washington Radio Central recently and copied before the San Francisco operator indicated its receipt. Needless to say, it was not relayed to Washington. This message was copied without error over 11,500 miles of sea and land.

Radio for English Travelers

LONDON, ENG.—The Liverpool Express, a fast train running between Liverpool and London, has been equipped with a powerful receiving set, loud speaker and loop aerial, which are located in a special Radio salon, where the passengers can be amused and interested during the tedious journey.

We Live In Kansas

—but we receive programs from Atlanta, Minneapolis, Davenport, Fort Worth, Madison, Los Angeles, Dallas, Kansas City, St. Louis, Denver and San Antonio on Crystal without batteries. Your crystal set requires only easy inexpensive changes. Send stamp for further information or \$1.00 for copyrighted drawings and instructions. Everything explained. Satisfaction guaranteed.
LEON LAMBERT, 501 South Volusia, Wichita, Kansas

ETHER COMPASSES FOR NAVY BLIMPS

Officials Consider Plan to Equip Big "ZR" Ships for Dark and Fog Navigation

WASHINGTON.—Plans for equipping the two new naval rigid airships with Radio compasses so that they can navigate in darkness or in fog, are under consideration. These are the great ZR ships now building.

It is believed that the Radio compass installations can be made satisfactorily, and that this feature will prove a valuable asset for the efficiency and safety of both personnel and material through assisting the accuracy of navigation. The location selected was adjacent to the observation platform located on top of the ship, well forward. A coil has been designed which will enable observations to be made in frequencies extending over a band of from, approximately 600 to sixteen kilocycles. If this installation is made satisfactorily, it will be the first time a Radio compass has been successfully installed upon a lighter-than-air craft.

Give WBAP's "Hired Hand" Miniature of His Cowbell

FORT WORTH, TEX.—G. C. Arnoux, Radio Editor, Star-Telegram, Fort Worth, Texas, alias announcer GCA or "The Hired Hand," who daily wields the cowbell before the microphone of WBAP is proudly displaying a miniature gold cowbell, patterned along the style of the original. This unique token is inscribed "From Gainesville 147-piece Boys' Band, C. C. Shell, Director, to 'The Hired Hand'." It was presented to the popular announcer by the band which was heard several weeks ago, broadcasting from Station WBAP, and complimentary acknowledgments were received by the Gainesville, Texas, band from nearly every State in the Union.

Premier Radio Products

Are all their name implies

Why not begin standardizing now?

- Variocouplers
- Transformers
- Rheostats
- Potentiometers
- Head Sets
- Resistances
- "Microstats"
- Dials and Knobs
- Condensers
- Jacks
- Plugs

Correspondence solicited from responsible distributors

Write today for Radio "Paris" Bulletin.

Premier Electric Company

Established 1905
3810 RAVENSWOOD AVENUE
CHICAGO, ILL.

"Radio Eye" Guide for London Derby Traffic

Flying Scouts Flash Road Conditions to Grandstand Box

LONDON, ENG.—Radio waves again controlled the immense tide of traffic that rolled into Epsom for the derby recently.

From a box in the grandstand one man observed to see just what was happening to the streams of vehicles for twenty miles around. The trek to Epsom began the night before the race and from dawn until the classic was run there was a steady influx by all roads.

This man was able to see through the eyes of his Radio scouts, some of whom were flying over the course, and others touring the approaches in automobiles. Each was in direct communication with the "master eye."

Col. Laurie of the British air ministry, who was in charge of Radio communication at the course, declared that this was the second time Radio had been so used, and had proved very satisfactory.

CUNNINGHAM TUBES REPAIRED

C-300 or UV-200\$2.75
C-201 or UV-201 3.00
C-302 or UV-202 3.50
C-201A or UV-201A 3.50
WD-11 or WD-12 2.75
Moorehead Detectors 3.00
Moorehead Amplifiers 3.00
DV-6 or DV-6A 3.00
Also the new UV-199 3.50
NEW DX 1 1/2 VOLT TUBES 4.00

All tubes guaranteed to work like new.

Mail Orders Given Prompt Attention "24 Hour Service"

RADIO TUBE CORP.

55 Halsey Street Newark, N. J.
TUBES SENT PARCEL POST, C. O. D.

a Chi-Rad Special!



for W.D.11 tubes—

Standard, threaded rubber, Willard's specially adapted for use with WD-11 Tubes. Supply current at 2 volts to one WD-11 Tube for 210 hours on a single charge. Rechargeable. Brand new, size 4x5 1/2 x 7 inches—Chi-Rad guaranteed.

2-Volt Willard Charged... \$7.50
2-Volt Willard Dry... 6.50

These same Willards can be adapted to deliver 8 volts for pure D. C. for C. W. Transmitters. Better than a generator because no filter is necessary. Much less expensive.

In lots of 40 (320 volts) \$160.00
(Better prices on larger quantity)
Specify dry or charged when ordering.

Chicago Radio Apparatus Co.
415 S. Dearborn St., Chicago, Ill.

New CARTER Vernier Control RHEOSTAT

Simple, positive, distinctive, reliable. Satin silver finish; clock spring plaital connection insures positive and reliable operation.
Code 1, 6-ohm, for U. V. 200 tube... \$1.50 ea.
Code 1-C, 20 ohm, for U. V. 201-A tube... 1.75 ea.
Code 1-D, 30-ohm, for U. V. 199 tube... 1.75 ea.
Write for Bulletins of Carter Products
CARTER RADIO COMPANY
209 S. State St., CHICAGO

Build Your Own HAZELTINE NEUTRODYNE with FREED-EISEMANN

Licensed Essential Parts

Complete wiring diagram, instructions, etc. sent in special container with patented essential parts. Three NEUTROFORMER COILS mounted on variable condensers, and DOUBLE NEUTRODON (as illustrated), sent for \$21.50. Ask your dealer to show you these parts, as well as complete assembled five-tube Neutrodyne Set in mahogany cabinet, Model NR-5, \$150.

Or send 25c for Neutrodyne Constructor which shows "How to Make the Neutrodyne"

FREED-EISEMANN RADIO CORPORATION
Dept. B
255 Fourth Avenue New York
Licensed by I. R. M. Inc. Under Hazeltine Patents

HERE IT IS—

The New GREBE Broadcast Receiver

Your key to the true joys of radio!

Receive all broadcasting without outdoor antenna, loop, or storage battery!

The Receiver employs both Regeneration and Tuned Radio Frequency Amplification with only two simple tuning adjustments.

A Dial, graduated in wavelengths, enables you to locate quickly the program you desire.

The walnut cabinet, with its battery compartments, harmonizes with the most tastefully furnished room.

Licensed under Armstrong U. S. Pat. No. 1,113,149



Ask Your Dealer TODAY

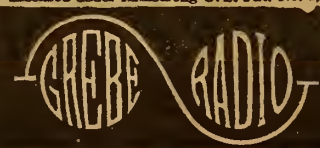

World's Smallest Regenerative Set

How to Construct Vest Pocket 800-Mile Tuner

By Warner Bates

THE world's smallest regenerative set! Much interest has attached to the recent announcement of the construction by Roslyn V. Russell, Niagara Falls, N. Y., of a peanut tube miniature regenerative set which can be carried in the pocket and yet will do all that could be expected of many larger and more complicated outfits. Mr. Russell completed the set during the winter and under favorable conditions listened in on broadcasting stations and amateurs in all but the sixth and seventh Radio inspection districts. A portable set indeed!

Dial Container Is Cabinet

Mr. Russell ordered a Sleeper dial and when it was delivered he found it housed in a wooden box 3 1/4 inches square by 1 1/2 inches deep. On receipt of the box the idea struck Mr. Russell that he could by ingenuity design a receiver to fit in the container.

The corners were reinforced by small 3/8-inch triangular blocks of wood with holes through their centers through which screws were passed to fasten the panel on the front of the box. A 5/8 by 2 1/2-inch hole was cut out of the back to pass the end of the sub panel which carries the three battery binding posts.

The panel is of 1/4-inch bakelite, 3 1/4 inches square. The sub panel is fastened to the front panel by two 8-32 flat head screws and is 2 1/2 inches wide by 2 inches deep.

Single Circuit Regenerative

The circuit used is an improved regenerative single circuit using a spider web coil tuned by a vernier variable condenser and a switch on the antenna inductance.

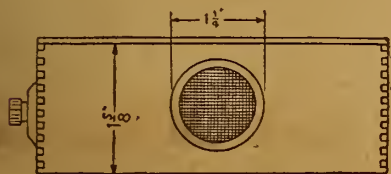

PLAN VIEW OF CASE

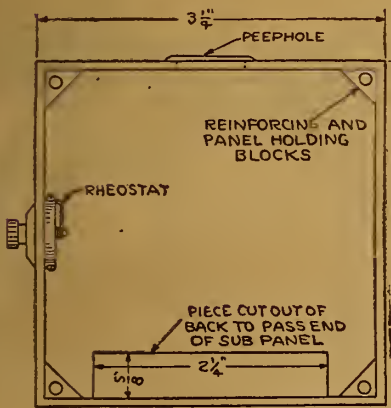

FRONT, PANEL REMOVED.

MINIATURE APPARATUS COMPARED TO WATCH

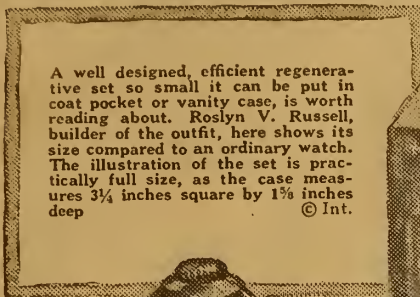

A well designed, efficient regenerative set so small it can be put in coat pocket or vanity case, is worth reading about. Roslyn V. Russell, builder of the outfit, here shows its size compared to an ordinary watch. The illustration of the set is practically full size, as the case measures 3 1/4 inches square by 1 1/2 inches deep. © Int.

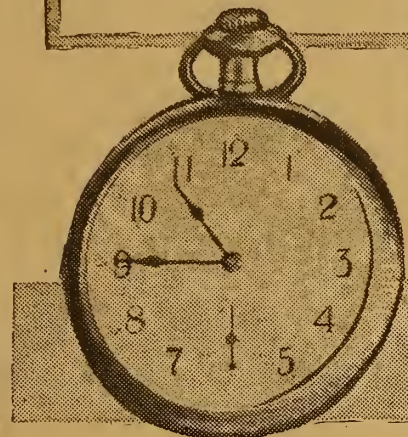

Winding and Connecting Spider Web

Fastened to the outside of the variable condenser by means of sealing wax at various points is the spider web coil.

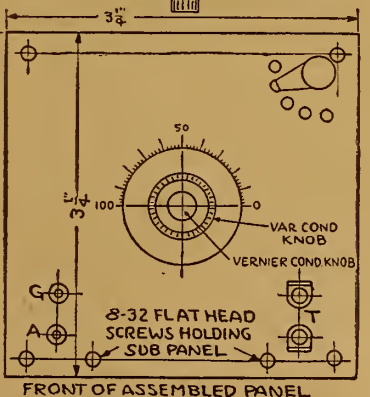
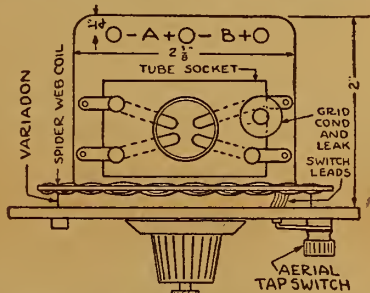

Figure 1

The tickler feedback has fixed coupling. Figure 2 shows the hook-up used and the number of turns in each part of the spider web coil.

As was stated, the secondary is tuned by means of a vernier variable condenser controlled by a vernier dial (small knob in the center) in the center of the panel. The condenser is a .0004 mfd. Variadon

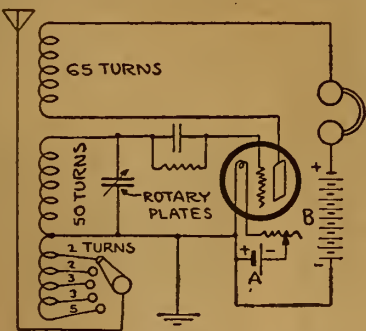

Figure 2

which was cut down from its normal 3 1/4 inch diameter to a size 2 1/2 inches square without, in any way, impairing its efficiency.

The shaft of the Variadon was drilled through the center to take a 1-16-inch brass rod, and a specially shaped brass vernier plate, shown in Figure 3 was soldered to the rod, which in turn was attached to the vernier knob of the dial.

Figure 4). This inductance is wound on a "former" 1 1/2 inches in diameter. Twenty-seven pins are mounted equidistantly on the edge of the former and the coil is wound with No. 30 single silk covered wire so as to pass through every second pin.

The tickler coil is wound first and consists of 65 turns. The wire is then broken and the antenna inductance of 15 turns

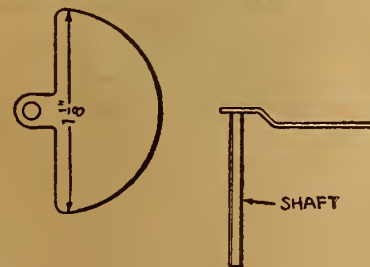
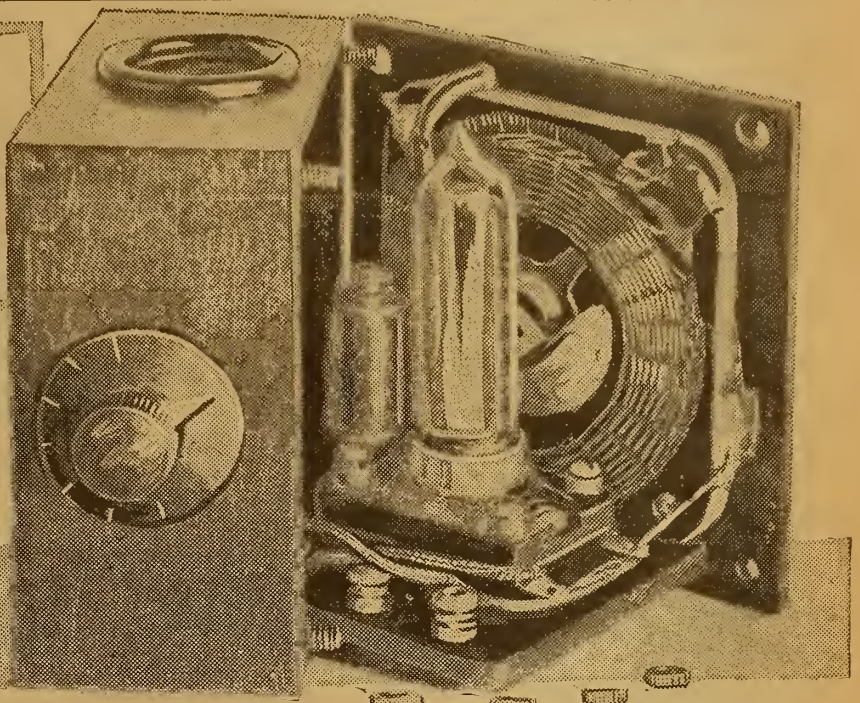

Figure 3

tapped at five points, started. The beginning of the antenna inductance goes to the 5th contact on the aerial tap switch; 5 turns are wound and a tap is brought to the 4th contact; 3 turns are wound and a tap is brought to the 3rd contact; 3 turns are wound and a tap brought to the 2nd contact; 2 turns are wound and a tap brought to the 1st contact, and finally 2 more turns complete the antenna inductance and the last tap is connected to the ground binding post and the Variadon rotating plates.

The wire is not broken at this point but winding is continued for 50 turns and the



end of the wire is connected to the grid condenser and leak and the fixed plates of the Variadon. The turns of the inductance after winding were doped with M-R No. 11 varnish. After this had dried thoroughly the pins and former were removed. Figure 4 illustrates clearly the method of winding and of taking taps.

Tube, Socket and Grid Leak

The tube used is a Northern Electric 215-A "peanut" with socket made by the same firm. To get the socket into the case it is necessary to trim the sides until the width is only 1 inch. The socket is mounted on the sub panel and a tubular

grid leak and condenser 3/8-inch long by 3/8-inch diameter is fastened directly to the grid binding post of the socket. Mr. Russell made his own grid condenser and leak from a small rolled paper condenser mounted inside a hard rubber tube with brass plugs on each end and with a pencil mark leak extending from one brass plug to another on the outside surface of the hard rubber tube. It is not necessary, however, to follow this practice as very small grid condensers and leaks are available on the market and will serve satisfactorily here.

(Continued on page 6)

Inland Electric Co. Chicago

A RADIO SUMMER?

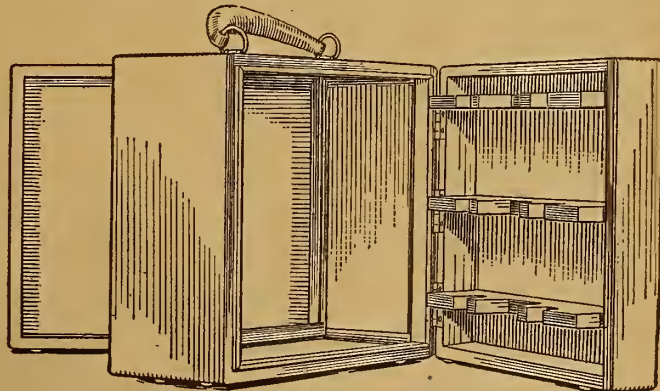

Brown mahogany finish portable cabinet, both front and back hinged, shelving in rear cover to fit No. 705 Flashlight "A" Batteries and No. 763 "B" Batteries; enough space for 3-tube set; head set fits in front cover, aerial in back. Complete, \$15.00.

ALSO

We are distributors for Atwater-Kent Radio Equipment and maintain a complete stock at all times.

IF YOUR DEALER HASN'T GOT IT, WE HAVE

INLAND ELECTRIC CO.

14 N. FRANKLIN ST.

CHICAGO, ILL.

Tune in to Inland

HOW AMATEUR CAN AID NATION IN WAR

INTERCEPT MESSAGES OF ENEMY AT FRONT

"Qualify in Radio—No Better Way to Serve," Says Signal Corps Officer

WASHINGTON.—There is practically no end to the possibilities of Radio for military use, an officer of the signal corps stated recently, adding that, young men who wish to serve their country can do so in no better way than to become qualified in Radio and to join the National Guard or Signal Reserve Corps of the U. S. Army.

As an instance of the work of former amateurs who served in the signal corps during the war, it is said that 73 percent of the 400 Radio men engaged in intelligence work were ex-amateurs. Not a single "leak" occurred in the service, which intercepted 73,000 enemy messages and recorded 175,000 bearings on enemy Radio stations. The country is greatly indebted to these amateurs for their war work.

Radio Intelligence Work

Although little was known of the work of the Radio intelligence section of the army during or since the war, it was one of the most spectacular. Radio direction finders were placed all along the lines, at a distance of about five miles from the actual front and spaced about twelve miles apart. These receiving sets located the enemy stations in operation, recorded their bearings by means of directional coils, not unlike modern Radio compasses, and forwarded the bearings to headquarters where they were plotted on maps. The reports from many American Radio observers enabled the staff to keep an accurate check on practically all the German stations all the time.

Other receiving stations at army headquarters, intercepted and copied all enemy code messages, and telegraphed them back to general headquarters where code experts worked them out, giving the staff valuable information as to the movements or intentions of the enemy.

German's Make "Faux Pas"

On one occasion, when the Germans were planning a big offensive, the code all along the line was suddenly changed. The old code, known by the Americans for some time, became valueless. But one German officer could not decipher a long message sent him in the new code and asked his commander to repeat it in the old one. This was done and as the American intercepting stations copied both messages, the staff of experts at headquarters soon had a fair solution of the new code, which they eventually worked out in its entirety. The repetition of the message in both codes was more than they hoped for, and when the new code was transmitted to the French and British headquarters, the American Radio intelligence service was credited with a big "scoop" in aiding the Allies in securing advanced information.

Vernier Var. Condensers

COMPLETE WITH KNOB AND 3 IN. RUBBER DIAL

\$5.00 Value 11 plate with 3 plate Vernier.....	\$2.00
5.50 Value 19 plate with 3 plate Vernier.....	2.15
6.50 Value 41 plate with 3 plate Vernier.....	2.50

Plain— 3 Plate\$0.75 23 Plate\$1.25
11 Plate98 43 Plate 1.50

Include 5c per item for parcel post.

CHI-CITY-RADIO CO.

945 CRESCENT PLACE, CHICAGO, ILL.

BRITAIN AIDS JAPAN TO BAR U. S. RADIO

Marconi Company's Six Gigantic Stations Will Establish Complete World Monopoly

SAN FRANCISCO.—Great Britain is using its diplomatic influence at Peking to aid Japan's opposition to the entry of American Radio companies to China, according to Emmett White, attorney, writer and former director of the insular and foreign division of the American Red Cross in China, who arrived from the Orient recently.

It is believed by American residents of Shanghai, says White, that with the completion of six gigantic stations reported to be under construction in England by the British Marconi Company, Great Britain hopes to establish a complete world monopoly of the air, assisted by Japanese stations in China and Manchuria.

The Federal Telegraph Company of this city is keeping the cables and telegraph wires busy with appeals to Washington, urging that the State Department take action on the reported refusal of the de facto government at Peking to live up to the terms of an agreement permitting the installation of Federal Radio stations at six Chinese ports.

Fort Worth Bids for Third Big G. E. Plant

Location in Southern U. S. Held as Inducement

FORT WORTH, TEX.—The tremendous Radio interest in the territory for hundreds of miles around Fort Worth, largely developed through Station WBAP, and the fact that Fort Worth is near the center of the southern half of continental United States, is offered as an inducement in bidding for the third huge broadcasting station which the General Electric Company is planning.

The ordinary service radius of a station of this kind would be more than 1,500 miles. A similar station is now being erected at Oakland, Calif., and the parent station is WGY, Schenectady, N. Y.

Place Radio in Hospital to Cut Use of Narcotics

NEW YORK.—A complete Radio outfit with more than 150 headsets is installed in Beth Israel hospital for use of the patients. Louis J. Frank, superintendent, said he believed Radio would diminish the giving of narcotics and sleeping potions and ease the patient's mind.

Cockaday Circuit TUNER COILS

BC AND D COILS

Complete as per specifications

No. 18 Wire Used—D Coil Bankwound. Price, \$2.75

Hook-up, directions and material list furnished free with each set of coils.

MAIL ORDERS FILLED
Dealers, Communicate

Eastern Radio Mfg. Co.
22 Warren St., Dept. R.D., New York, N.Y.

SMALL REGENERATOR

(Continued from page 5)

Rheostat Homemade

Because there is very little space on the panel the filament rheostat is fastened on

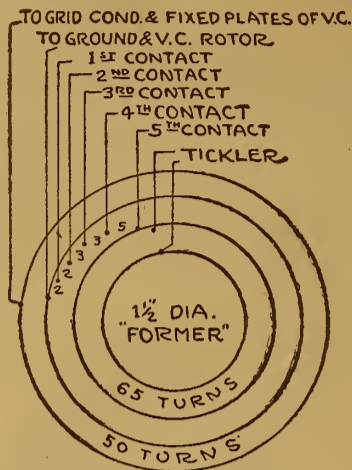

Figure 4

the left side of the case. There being none small enough on the market, the rheostat is made from a piece of 7/8-inch diameter hard rubber rod, 1/4-inch thick, and grooved on its outer edge to take the resistance wire coil. The contact blade is 3/8-inch long and is turned by a 3/4-inch knob and dial 1 1/8-inch in diameter mounted in the center on the left side of the case as shown in Figure 1.

The peephole in the top of the case consists of a hard rubber ring, 1 1/4 inches in diameter, below which is fastened a circle of nickel plated screen.

Special Sets Made to Order

Let us quote you on any circuit. Sets made under expert supervision. We repair sets and test tubes.

FORBES RADIO CO.
127 N. Dearborn St. Chicago, Ill.

Crystal Fans Wake Up

"The Vacuum Tube's Only Rival"
Lasts Indefinitely

50c  50c
Approved by Mail, Tribune, Radio World
Make your set sound like a brass band

RADIO CORPORATION OF AMERICA OPERATES use the L. D. R. Crystal as detector in conjunction with one or more stages of amplification. Satisfaction Guaranteed or money refunded.

JACK BINNS OF S. O. S. FAME

Radio Ed. Tribune Radio Laboratory, recently awarded a certificate of excellence to the L. D. R. Super-Crystal, stating—"The L. D. R. Super-Crystal is exceptionally sensitive and covered with many amplification spots. All that can be desired in a real good radio crystal that will last indefinitely."
FREE Crystal Amplification Hook-ups.
FREE the 1000 Mile One Tube Reflex Hook-up.

JAYNXON LABORATORY
57 Dey St. New York City

Kellogg Radio Equipment For Better Results



VARIOCOUPLER

The Kellogg variocoupler is of the same standard design as our variometer, being made of molded Bakelite, with reinforced construction.

For increasing the wave length from 500 to 2,500 meters, the Kellogg standard wound induction is added to the variocoupler.

It is arranged for either panel or base mounting. No. 501 Variocoupler \$9.00
With No. 502 Diamond Wound Coil, as shown in illustration. \$13.00

Kellogg Switchboard & Supply Company
CHICAGO

Front Panel Assemblies

The front view of the assembled panel is shown in Figure 1. The antenna switch is in the upper right corner of the panel, surrounded by five contact points. In describing the winding the contacts were referred to as first, second, third, etc. First means the contact nearest the top, while the fifth contact means the one farthest to the right.

The two lower left binding posts marked G and A are for ground and aerial respectively, while the two lower right binding posts equipped with phone tip clips are for the headset.

It is well to note here that the ground binding post and the aerial switch lever screws go through the screw holes in the Variadon, thus serving to fasten the latter to the front panel.

The four holes in the corners of the panel pass the brass machine screws fastened through the reinforcing blocks in the corners of the case, and small knurled knobs fasten to these screws to hold the panel and attached apparatus in the case.

This remarkable miniature regenerative set occupies an extremely small space and has excited great interest in Radiophan circles, not only on account of its size but because it has consistently received stations 800 miles away.

A meter is equal to 39.37 inches.

TWO SUPERSENSITIVE CIRCUITS

(Both Copyrighted)

My Highly Improved Reinartz brings in all important stations on both coasts and Mexican border, loud, clear and without distortion. We dance to music from Atlanta received on one loud Baldwin unit. Build one of these wonderful sets from my blueprints and specifications, price 50c, or with a perfect and complete double wound spiderweb coil, \$3.00 by mail. No other windings used. Photo of my set on a glass panel with every order.

This copyrighted circuit is the most successful of any Reinartz modification yet produced, and is imitated the most. Thousands are in use.

My W. D. #1 Circuit is especially designed for use with the "Pickle" tube and brings out the full value of that little tube as no other circuit can. Stations 1000 miles away come in clearly on one tube. This set is small, complete, portable. For the man who wishes the highest efficiency this is the set to build. Price of blueprint and specifications, 50c, or with complete and perfect windings, \$3.00. Photo of set with every order.

Either set as easy to build, easy to operate. Everything clearly shown.
Sets built from these plans will receive all broadcasting stations operating under the new laws. Their wave length range is from 140 to 870 meters.

S. A. TWITCHELL
1925 Western Ave. Minneapolis, Minn.

How to Make a Flewelling Receiver

BLUE PRINTS

for the construction of a Flewelling Receiving Unit and two step amplifier.

ALL DETAILS FOR ASSEMBLY

Description of apparatus and accessories and details of tuning.

CABINET DIMENSIONS
PANEL LAYOUTS
LIST OF PARTS

Send only money orders—no checks or stamps. Coins at your own risk.

Book Department

Radio Digest
123 W. Madison St., Chicago, Ill.

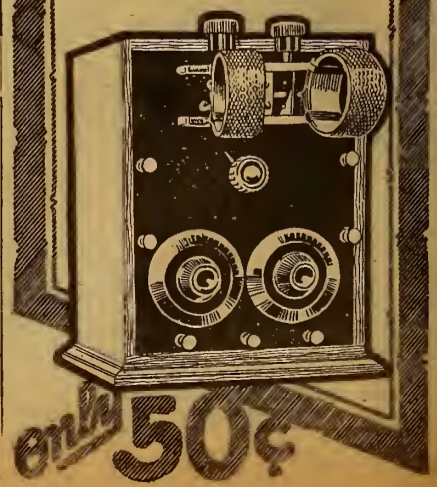

FORMICA

A Laminated Phenolic Condensation Product
SHEETS TUBES RODS

RADIO PANELS

POLISHED BLACK FINISH

CUT PERFECTLY SQUARE TO ANY SIZE

1/32" THICK	1/2¢	PER SQ. INCH
1/16" THICK	3/4¢	PER SQ. INCH
3/32" THICK	1¢	PER SQ. INCH
1/8" THICK	1 1/2¢	PER SQ. INCH
3/16" THICK	2¢	PER SQ. INCH
1/4" THICK	2 1/2¢	PER SQ. INCH
3/8" THICK	4¢	PER SQ. INCH
1/2" THICK	5 1/4¢	PER SQ. INCH

SEND FOR COMPLETE PRICE LIST
PROMPT ATTENTION TO MAIL ORDERS
DEALERS PRICES ON APPLICATION

STARRETT MFG. CO.
519 SOUTH GREEN ST. CHICAGO

DONT PASS THIS-BUY



Every World User Is a Booster
WRITTEN 2 YEAR GUARANTEE

Because you deal direct with a manufacturer who is responsible for the performance and quality of the Battery.

World-Radio-Batteries	
6 Volts—40 Amps., \$8.50	6 Volts—80 Amps., \$12.50
6 Volts—60 Amps., \$10.00	6 Volts—100 Amps., \$14.50
6 Volts \$16.00 120 Amps.	

Full Rating Guaranteed
MAIL YOUR ORDER TODAY. WE SHIP EXPRESS C. D. D. SUBJECT TO INSPECTION. DR WILL ALLOW 5% FOR CASH WITH ORDER. ALL ORDERS SHIPPED SAME DAY AS RECEIVED.

WORLD BATTERY COMPANY,
60 E. Roosevelt Rd., Dept. L, Chicago, Ill.

The Week's Advance Broadcast Programs

Tuesday, June 19

CFCA (Eastern, Daylight Saving, 400), 8:00-9:00 P. M., Musical program, "Three Dances from Henry VIII," Star Orchestra; "The Hills of Donegal," Archibald Munro, baritone; "Luna," Orchestra; Yolkin solo, "Minnie Roth," Selection from "Luna," Love, Orchestra; "The Farmer's Wife," Archibald Munro, baritone; "Hungarian Dance, No. 11," Minnie Roth; "Three for Jack," Archibald Munro, baritone.

KHJ (Pacific, 400), 12:30-1:15 P. M., Concert, Baisden's Bon Ton Orchestra; 2:30-3:30 P. M., Musical matinee, Georgia Stark; 8:00-10:00 P. M., Concert, Southern California Saxophone Band.

KSD (Central, 546), 8:00 P. M., Program by Choir of St. Paul's Church.

KYW (Central, Daylight Saving, 345), 8:00 P. M., Musical program, Laura E. Burlin, soprano; Lucille Maiker, soprano; George Daubach, tenor; Cope Harvey's Orchestra; Sketch, "The Trussard," from "The Tamer of the Shrew," Rosary High School, River Forest, Ill.

WBAP (Central, 476), 9:30-10:30 P. M., Concert, Texas Hotel Orchestra.

WDAR (Eastern, Daylight Saving, 395), 12:00-12:54 P. M., Organ recital from Stanley Theater; Dinner music, Arcadia Cafe Orchestra; 2:00-3:00 P. M., Musical program; 4:30-6:00 P. M., Song recital; "Affairs of the Heart," Betsy Logan; 7:30-8:00 P. M., Dream Daddy.

WFAA (Central, 476), 12:30-1:00 P. M., Address, DeWitt McMurray; 8:30-9:30 P. M., Concert, Band from Ennis, Texas; 11:00-12:00 P. M., Musical program under auspices of W. A. Green Company.

WFI (Eastern, Daylight Saving, 395), 1:00 P. M., Dinner music, Meyer Davis Bellevue Stratford Orchestra; 3:00 P. M., Recital; 3:45 P. M., Song Recital; 6:30 P. M., 7:00 P. M., Dinner music, Meyer Davis Bellevue Stratford Orchestra; Safety talk, Stanley Cox; 8:00 P. M., Boy Scout period, Boy Scout Radio Corps; 8:30 P. M., Musical program; 10:30 P. M., Dance music, Meyer Davis Bellevue Stratford Orchestra.

WGY (Eastern, 380), 1:00 P. M., Music and address, "The Drama," Mrs. Ralph Jecklin, Schenectady Woman's Club; 7:35 P. M., Address, "Wasting Our Nitrogen," Russell Suter, N. Y. State Conservation Commission; 7:45 P. M., Musical program, "Scherzo Caprice," WGY Instrumental Quartet; "Spartacus to Caprice," John N. Donovan, reader; "Un Giorno in Venezia," Alba, "Gondolieri," Quartet; "The Message of the Violet," LeRoy Pickett, baritone; "Canzone Amoroosa," "Buona Notte," Quartet; "King John N. Donovan," "Pastorale," Edward A. Rice, Leo Kliven, violinists; "The Old Road," "For You Alone," "My Jeannie," LeRoy Pickett; "Intermezzo Al Fresco," Quartet.

WHAS (Central, 400), 4:00-5:08 P. M., Concert, Mary Anderson Orchestra; Clifford Gorman, organist; 7:30-9:00 P. M., Concert, Resta Trio, George C. Resta, piano; Mrs. Nicholas Bosler, Jr., violinist; Maurice Menneue, clarinetist; Fannie E. Stoll, pianist; Henry Holweger, artist; Evelyn Kaiser, violinist.

WHK (Central, 360), 8:00 P. M., Concert, WHK Trio; Babson's Radio Release; Automobile road report.

WIP (Eastern, Daylight Saving, 509), 9:00-4:30 P. M., Artist recital; 6:00-6:45 P. M., Bedtime stories, Uncle Wiggly; 7:00-7:30 P. M., Bedtime stories, Uncle Wiggly; 8:00 P. M., Musical program; 9:00 P. M., Song recital and short talk.

WLW (Central, Daylight Saving, 309), 10:00 P. M., Entertainment by Cincinnati Rotary Glee Club; Joseph Schenke, tenor.

WMAQ (Central, Daylight Saving, 447), 7:00-8:00 P. M., Program by Axel Christensen, The "Rap-Time King"; Babson Report; Saxophone solos, Gardner J. Huff; 9:15 P. M., Program arranged by Mrs. Ruby Donaldson.

WMC (Central, 400), 8:30 P. M., Program arranged by Mrs. Garner Strickland; 11:00 P. M., Midnight Frolic.

WDC (Central, 484), 3:30 P. M., Educational talk, A. H. Hebb; 5:45 P. M., Chimes concert.

WDD (Eastern, Daylight Saving, 509), 11:00-11:30 A. M., Organ recital, Mary E. Vogt; 12:00-12:55 P. M., Luncheon music, Tea Room Orchestra; 4:45-5:00 P. M., Organ recital, Mary E. Vogt.

WJW (Eastern, 517), 8:30 P. M., Concert, News Orchestra; Town Crier; Hudson Tschirhart, Japanese actor; Thelma Hull, pianist; Charles Marjanian, tenor.

Musical program, Rosemary Ellerbrock; Children's play, "Little Boy Blue," Students of Reimann School of Expression; William Steves, violinist, Concert, "Spirit Flower," Richard Pavoy, tenor; "Vision Fugitive," Herbert O. Schatz, baritone; "In the Dark, In the Dew," Long for You, Richard Pavoy; "Forza del Destino," Richard Pavoy, Herbert O. Schatz; William Steves, violinist; "Give a Man a Horse to Can Ride," Herbert O. Schatz; "Requiem," Richard Pavoy, tenor; William Steves, violinist; "To You," "Requiem," Herbert O. Schatz; Duet from Mrs. Chas. Semplo; Hazel McClennan, soprano; Miss Ellenberger, pianist; Mary E. Vogt, pianist.

WIP (Eastern, Daylight Saving, 509), 3:00-4:00 P. M., Artist recital; 4:30 P. M., Musical program; 6:00-6:45 P. M., Dinner music, and baseball scores; 7:00-7:30 P. M., Bedtime stories, Uncle Wiggly; 8:00 P. M., Short talk; 9:00-9:30 P. M., Organ recital, Karl Bonawitz.

WLW (Central, Daylight Saving, 309), 10:00 P. M., Musical program, "Sonata in G Major," Marjory Garrigus, pianist; "Vaive from Traviata," George

KSD (Central, 546), 8:00 P. M., Opera, "Prince of Pilsen," Municipal Theater.

KYW (Central, Daylight Saving, 345), 8:00 P. M., Musical program, Mabel Timus, soprano; Homer Colclinton, baritone; Lewis Meelan, tenor; Ileric Soimoon, pianist; Cope Harvey's Orchestra; Wendell W. Hall, KYW's Music Maker; 9:05 P. M., Book reviews, Lowly Jones.

WBAP (Central, 476), 9:30-10:30 P. M., Program furnished by Fort Worth Chamber of Commerce.

WDAR (Eastern, Daylight Saving, 395), 12:00-12:54 P. M., Organ recital from Stanley Theater; Dinner music, Arcadia Cafe Orchestra; 2:00-3:00 P. M., Short talks; 4:30-6:00 P. M., Musical program; "Affairs of the Heart," Betsy Logan; 7:30-8:00 P. M., Bedtime Stories, Dream Daddy; 8:00 P. M., 4:30 P. M., Short talks; One-act playlet; Musical selection; Dance music, Howard Lanin's Arcadia Cafe Dance Orchestra; Selections by the Morning Glory Club and special features.

WFAA (Central, 476), 12:30-1:00 P. M., Address, Dr. Robert S. Hyer, Southern Methodist University; 8:30-9:30 P. M., Program by First Baptist Church, Denton, Texas.

WFI (Eastern, Daylight Saving, 395), 3:00 P. M., Song recital; 6:20 P. M., Final baseball scores; 7:00 P. M., Children's Own Half Hour, Cousin Sue.

WGY (Eastern, 380), 1:00 P. M., Music and address, "Systematizing Housework," 5:30 P. M., Children's program; 7:35 P. M., Talk, "The Child's Mental and Physical Health," State Dept. of Health; 7:45 P. M., Radio drama, "The Great Divide," WGY Players; 10:30 P. M., Musical program, "Menuette all' antico," WGY Instrumental Quartet; "Absent," "Haymaking," "Atlee K. Monty, soprano; "Caprice Vanilly," "Quartet," "Folia de Concha," Mary Weich, pianist; "Legende," Quartet; "De Scrumptious Wedding," Minnie Vines, reader; "Le Cor," "Do Possente," Albert Cook, baritone; "Canzonetta," Quartet; "Voco di Primavera," "Mighty Lak a Rose," Helene Healy; "Serenata," Quartet.

WHAS (Central, 400), 4:00-5:00 P. M., Concert, Mary Anderson Orchestra; Clifford Gorman, organist; 7:30-9:00 P. M., Concert, Evelyn Campbell, soprano; William Fries, artist; Thomas Simon, pianist; William Fries, baritone; J. O. Noble, violinist; Florence King, reader; J. D. Brecker, baritone; Geraldine McNeely, pianist; Mary Louise Kubaug, violinist; Craig Walker, reader.

WIP (Eastern, Daylight Saving, 509), 3:00-4:00 P. M., Dance program; 4:00-4:30 P. M., Artist recital; 6:00-6:45 P. M., Dinner music and baseball scores; 7:00-7:30 P. M., Bedtime stories, Uncle Wiggly.

WMAQ (Central, Daylight Saving, 447), 7:00-8:00 P. M., Stories, Jessie G. Van Cleeve; Musical lecture, Mrs. Mary E. Ebernförfer; 9:15 P. M., Concert, The Whitney Trio.

WMC (Central, 400), 8:30 P. M., Concert, Janssen Cafe Hawaiian Orchestra; 11:00 P. M., Midnight Frolic.

WDC (Central, 484), 3:30 P. M., Educational talk, C. E. Wilent; 5:45 P. M., Chimes concert.

WDD (Eastern, Daylight Saving, 509), 11:00-11:30 P. M.

What Time Is It?



THE above clock dials are shown to clear up the misunderstanding which the various time bands and the Daylight Saving plan are creating. Although each dial registers time one hour ahead or behind of its neighbor, the exact period indicated on each dial is the same as that on every other. This chart will aid in the use of the advance programs and the schedules in the Radiophone Broadcasting Station Directory, both of which give the hours stated in the particular kind of time in use at each station. Only features are listed in the advance programs below. Much additional data and such parts of station schedules as are regular features week in and week out, will be found in the station directory which appears serially continuously on page eight.

"Lily of Killarney," "The Moon Has Raised Her Lamp Above," Richard Pavoy, Herbert O. Schatz.

WMAQ (Central, Daylight Saving, 447), 7:00-8:00 P. M., Stories, Georgene Faulkner; Musical program, Chicago Schools Committee; Eleanor Schweitzer, soprano; Mrs. Helene Uhlir, violinist; Helen Brown, pianist; 9:15 P. M., George J. Hill, Jr., baritone; Mrs. Louis Kohn, soprano.

WOC (Central, 484), 3:30 P. M., Educational talk, D. K. Kirk; 8:00 P. M., Organ recital, Mrs. Frank W. Elliott; 10:00 P. M., Musical program, Talent from Burlington, Iowa.

WOD (Eastern, Daylight Saving, 509), 11:00-11:30 A. M., Organ recital, Mary E. Vogt; 12:00-12:55 P. M., Luncheon music, Tea Room Orchestra; 4:45-5:00 P. M., Organ recital, Mary E. Vogt; 7:45 P. M., Recital; 8:15-8:45 P. M., Musical program; 8:45 P. M., Dance music, Hotel Adelphia Orchestra, A. Candelori, director; 9:45 P. M., Song recital.

WVJ (Eastern, 517), 8:30 P. M., Concert, News Orchestra; Town Crier; Mrs. Violet Hunter, pianist; Genevieve Zellner, soprano; Herbert Lamb, baritone.

Maier, flutist; "Arabesque," Marjory Garrigus; "Friend," "Fear Not Ye O Israel," Mrs. R. L. Flickinger; "Try Seaming Eyes," "The Story of a Rose," Eugene Schmidt; "Valse," Marjory Garrigus; "Berceuse," "Hungarian Serenade," George Maier, flutist; "Micaela's Air" from "Carmen," Mrs. R. L. Flickinger; "Rose of My Heart," "Rose in the Bud," Eugene Schmidt.

WMAQ (Central, Daylight Saving, 447), 7:00-8:00 P. M., Talk, Rockwell Stephens; "Chicago Scout Camps," C. A. Edson; John Wheeler, astrologist; 9:15 P. M., Evelyn Bostleman, soprano; E. Fred Wise, baritone.

WMC (Central, 400), 8:30 P. M., Concert, Hotel Cbisca Pbilharmonic Orchestra, Clara Abern, director.

WDC (Central, 484), 3:30 P. M., Educational talk, Karl G. Stephan; 5:45 P. M., Chimes concert.

WDD (Eastern, Daylight Saving, 509), 11:00-11:30 A. M., Organ recital, Mary E. Vogt; 12:00-12:55 P. M., Luncheon music, Tea Room Orchestra; 4:45-5:00 P. M., Organ recital, Mary E. Vogt.

WVJ (Eastern, 517), 8:30 P. M., Concert, News Orchestra; Town Crier; Mrs. Wray, tenor; Fred Walters, baritone; Detroit Loric Trio; 11:00 P. M., News Orchestra; Fred Walters; Watson Saxophone Four.

Thursday, June 21

CFCA (Eastern, Daylight Saving, 400), 8:00-9:00 P. M., Musical program, Mirella, Star Orchestra; "O Flower of All the World," Amy W. Finden, Nelly Gill, soprano; "Serenade for Strings," "Intermezzo," orchestra; "Tango," Harry Adaskin, violinist; "Ave Maria," Nelly Gill, Minnie Roth; "Air De Ballet," orchestra; Violin solo, Harry Adaskin; "Morning," Nelly Gill; "Extase," orchestra.

KHJ (Pacific, 400), 2:30-3:30 P. M., Musical matinee, Eva Threw; 8:00-10:00 P. M., Program arranged by the Chamber of Commerce, Van Nuys, Calif.

KSD (Central, 546), 8:00 P. M., Broadcasting St. Louis Reception to President Harding anniversary.

KYW (Central, Daylight Saving, 345), 8:00 P. M., Musical program, Verona Langhammer, contralto; Frank Elliott, tenor; W. B. Freeman, reader; Edith Stone, pianist; 9:05 P. M., Reading, "Twenty Minutes of Good Reading," Rev. C. J. Fernin, S. J., Loyola University.

WBAP (Central, 476), 9:30-10:30 P. M., Concert, Lion Tamers Club Orchestra of Decatur.

WDAR (Eastern, Daylight Saving, 395), 12:00-12:54 P. M., Organ recital from Stanley Theater; Dinner music, Arcadia Cafe Orchestra; 2:00-3:00 P. M., Song recital; 4:30-6:00 P. M., Musical program; 7:30-8:00 P. M., Bedtime stories, Dream Daddy.

WFAA (Central, 476), 12:30-1:00 P. M., Address, DeWitt McMurray; 8:30-9:30 P. M., Concert, Band from Ennis, Texas; 11:00-12:00 P. M., Musical program under auspices of the Bush & Gerts Piano Co. Song recital; piano solo; 3:45 P. M., Short talk and song selections; 7:00 P. M., Short talks; 8:00 P. M., Musical program; 8:30 P. M., Song and piano recital.

WFI (Eastern, Daylight Saving, 395), 3:00 P. M., Song recital; piano solo; 3:45 P. M., Short talk and song selections; 7:00 P. M., Short talks; 8:00 P. M., Musical program; 8:30 P. M., Song and piano recital.

WGY (Eastern, 380), 1:00 P. M., Music and address, "Mental Hygiene—Who is Mentally Defective?" Eleanor A. Gray, N. Y. State Dept. of Education; 7:45 P. M., Musical program, Catholic Churches of Albany, Prof. Joseph D. Brodeur, director; "Ecce Sacerdos," "Ave Verum," United Choirs; "Salve Regina," "Ave Maria," Lady of Angels Choir; "Adoramus Te," "O Esca," "Astorium," Cathedral Quartet; "O Bone Jesu," "Ingrediente," "Pueri Hebraeorum," "Panis Angelicus," Cathedral Choir; "Laudate Pueri," "Tu es Petrus," "Ave Verum," "Tantum Ergo," United Choirs.

WHAS (Central, 400), 4:00-5:00 P. M., Concert, Mary Anderson Orchestra; Clifford Gorman, organist; 7:30-9:00 P. M., Concert, Al Gorman's Orchestra; Sunday School lesson, T. A. Luman; Talk on Child Welfare.

Friday, June 22

CFCA (Eastern, Daylight Saving, 400), 8:00-9:00 P. M., Musical program, Selection from "Gypsy Love," Star Orchestra; "Nervana," Frederick Rogers, tenor; "Demoselle Chic," "Laughing Eyes," Orchestra; Tenor solo, Frederick Rogers; "Ritornel," Jacques Stern, cellist; "Sleeping Beauty," Orchestra; Tenor solo, Frederick Rogers; "From the South," Orchestra.

KHJ (Pacific, 400), 8:00-10:00 P. M., Cantata, "The Holy City," Choir of Second Presbyterian Church, Los Angeles.

AEROVOX

No. 1010X

30 Ohm Rheostat
Excellent results assured with use on New Type Tubes

UV199A UV201A

Using small filament current
6 Ohm\$0.75
20 Ohm 1.09
30 Ohm 1.10

At your dealers. Otherwise sent postpaid on receipt of purchase price.

Write for catalog illustrating and describing our entire line of quality apparatus.
Territory Open for Jobbers

AEROVOX WIRELESS CORP
208 West 17th Street NEW YORK

Wednesday, June 20

CFCA (Eastern, Daylight Saving, 400), 8:00-9:00 P. M., Musical program, In the Evening, Star Orchestra; "Carnival of Venice," Estelle Fox, soprano; "The Bohemian Girl," Orchestra; "Sextette from Lucia," Robert Dixon, W. Woods; "The Ruins of Athens," Orchestra; "Carmen," Estelle Fox, soprano; "The Better Land," W. Woods, cornetist; Soprano solo, Estelle Fox; Mary From, soprano; Orchestra.

KHJ (Pacific, 400), 2:30-3:30 P. M., Musical matinee; Talk "Beauty, Health and Charm," Rae Victor; 8:00-10:00 P. M., Concert, Venice America Band.

KSD (Central, 546), 8:00 P. M., Recital, C. W. Williams; 8:45 P. M., Concert, Rotary Club of Independence, Kans.

KYW (Central, Daylight Saving, 345), 8:00 P. M., Musical program, Mrs. Marie Ort, soprano; Max Bogolub, violinist; Emma Starman, contralto; Rose Stein, pianist; George Contrails, baritone; Cope Harvey's Orchestra; Wendal W. Hall, KYW's Music Maker.

WBAP (Central, 476), 9:30-10:30 P. M., Concert, E. Clyde Whitlock's violin ensemble.

WDAR (Eastern, Daylight Saving, 395), 12:00-12:54 P. M., Organ recital from Stanley Theater; Dinner music, Arcadia Cafe Orchestra; 2:00-3:00 P. M., Musical program and short talks on fashion; 4:30-6:00 P. M., Song recital; "Affairs of the Heart," Betsy Logan; 7:30-8:00 P. M., Bedtime stories, Dream Daddy; 8:00 P. M., Short talks and song recital; Dance music, Howard Lanin's Arcadia Cafe Dance Orchestra.

WFAA (Central, 476), 12:30-1:00 P. M., Musical program, Mable Thester.

WFI (Eastern, Daylight Saving, 395), 3:00 P. M., Song recital; 3:45 P. M., Musical program; 7:00 P. M., Children's Own Half Hour, Cousin Sue.

WHAS (Central, 400), 4:00-5:00 P. M., Concert, Mary Anderson Orchestra; Clifford Gorman, organist; 7:30-9:00 P. M., Myrtle Stinger, soprano; Sarah Lee, pianist; Mrs. Betty Kanzinger, soprano; H. Archer Culmer, tenor; J. Henry Brady, guitar; Reading, "An Interesting Historical Episode."

WIP (Eastern, Daylight Saving, 509), 1:00-2:00 P. M., Organ recital, Karl Bonawitz; 3:00-4:30 P. M., Musical selections; 6:00-6:45 P. M., Dinner music; 7:00-7:30 P. M., Bedtime stories, Uncle Wiggly.

WLW (Central, Daylight Saving, 309), 8:00 P. M.

CRYSTAL RECTIFIER
MULTIPOINT (Patent Pending)

A Synthetic CRYSTAL DETECTOR sensitive over its entire surface. Eliminates all detector troubles. Extraordinary clearness and volume. Endorsed by Radio experts and press for both REFLEX CIRCUITS and CRYSTAL SETS. Sold in Sealed Packages only.

Price mounted, Sensitivity guaranteed..... **50c**

RUSONITE CATWHISKER
14 Karat Gold Multiple Contact Super Sensitive..... **25c**

Order from your dealer or direct from us.

RUSONITE PRODUCTS
19 Park Row, New York

PHANTOM-CIRCUIT

Build Your Own. This marvel of mystery, using no loop, no aerial and no ground, brings in music instead of interference. We have heard stations 930 miles distant on one tube. By using WD-11 tube set can be entirely self contained. Very easy to build from our instructions, use your own spare parts, nothing complicated like radio frequency or super regenerative. Only one tuning control. Complete instructions, with hookup and photo of circuit mailed to you for 60 cents. Stamps accepted.

VESCO RADIO SHOP, Box D-704, Vacaville, Calif.

The latest and most essential part of an efficient tube set

Variable Resistance Leak FOR PANEL MOUNTING

Mounted on any panel in a few seconds—2 screws serving as connections behind panel.

Get stations you never heard before

No pencil markings—assure unbroken range of 180 degrees. Clarifies signals—eliminates hissing.

Complete with either .00025 or \$1.00 .0005 mfd. Micon Condenser Without Condenser75c

At your dealers—otherwise send purchase price and you will be supplied postpaid.

Chas. Freshman Co. Inc.
Radio Condenser Products
106 Seventh Ave. New York

"MAKE PERFECTION YOUR SELECTION"
We Carry Only STANDARD Advertised Radio Equipment. Every Product Sold on a MONEY BACK GUARANTEE.

MAGNAVOX LOUD SPEAKER, Type R, 3.....	\$24.95
N. & K. PHONES 6000 Ohms. None Better Made for DX Reception. Imported. List \$16.00	\$6.50
"B" BATTERIES	Our List Price
EVEREADY—No. 763—22½ Volts.....	\$1.75
EVEREADY—No. 767—45 Volts.....	5.50
BRIGHT STAR—No. 15—50—22½ V.....	1.75
BRIGHT STAR—No. 15—00—22½ V.....	1.45
BRIGHT STAR—No. 30—90—45 Volts.....	5.00
FRANCO—No. 1529V—22½ Volts.....	2.50
FRANCO—No. 3045V—45 Volts.....	5.75
CABINETS	
Extra fine quality—Hinged top—Mahogany finish.	
7x10.....	\$2.75
7x18.....	7x18.....
7x12.....	2.95
7x14.....	3.25
12x14.....	3.95
FLEWELLING CIRCUIT Complete parts, including PANEL, Double Coil Mounting and 2 Honeycomb Coils, Mounted. ONLY Standard Equipment Used. FREE DIAGRAM.....	\$11.95
REINARTZ CIRCUIT Complete parts for this remarkable set. FREE DIAGRAM.....	\$9.95
WESTERN ELECTRIC Phones. None better made. List \$12.00. Our price.....	\$7.95
PANELS—3/16" Thick	
Hard Rubber Bakelite	Hard Rubber Bakelite
7x16.....\$1.65	7x10.....\$0.95
7x12.....1.85	7x12.....1.25
7x14.....2.15	7x14.....1.40
7x18.....2.75	7x18.....3.95
VT-2 TUBES—Genuine Western Electric Tubes THE BEST AMPLIFYING TUBES MADE	
PERFECTION RADIO CORPORATION, Add parcel post. Do not send stamps.	
59 Cortland St., NEW YORK CITY	

Radiophone Broadcasting Stations

Corrected Every Week—Part I

AG6, Canton, O. 425 meters. 500 mi. Hdqrs. 135th Field Artillery Co. N. G. Wed, Fri, music. Sun, church services. Eastern.

AS6, San Antonio, Tex. 360 meters. 200 mi. U. S. Army. Ft. Sam Houston. Mon, Thurs, irregular.

AW7, St. Paul, Minn. 400 meters. 500 mi. 6th Inf. Minn. Nat'l Guard. St. Paul Armory. Daily ex Sun, 2-2:30 pm, music, announcements. Tues, 8:30-10 pm, Thurs, 8:30-9:15 pm. Central.

BEI, Tacoma, Wash. 400 meters. 100 mi. Camp Lewis, U. S. Army. Third Signal Co. Daily ex Thurs, Sun, 6-7 pm, music, announcements, lectures. Pacific.

CFAC, Calgary, Alta., Can. 430 meters. 1,000 mi. Western Radio Co. Ltd. (Calgary Daily Herald). Daily ex Sun, 12:30-1 pm, 3-4. Daily, 7:45-8:45 pm. Mountain.

CFCA, Toronto, Ont., Can. 400 meters. 500 mi. Toronto Star. Daily ex Sun, 12 m. weather; 2:30-3:30 pm, news, music; 5:30-6, news; 8-9, concert. Sun, 6:45-7:20, 8:45 pm, concert. Eastern Daylight Saving.

CFCB, Vancouver, B. C., Can. 440 meters. 1,500 mi. Vancouver Daily Province. Daily, 8:30-9:30 pm, reports, news, music. Pacific.

CFCE, Halifax, N. S., Can. 440 meters. 150 mi. Marconi Co. Mon, Wed, Sun night, music, entertainment.

CFE, Montreal, P. Q., Can. 440 meters. 1,000 mi. Marconi Co. Daily ex Sun, 1-1:30 pm. Monday, Wed, Fri, 7:30-9 pm. Eastern.

CFCH, Iroquois Falls, Ont., Can. 400 meters. 200 mi. Abitibi Power & Paper Co. Ltd. Daily, 8 pm, weather and stock reports. Experimental station. Eastern.

CFCK, Edmonton, Alta., Can. 410 meters. Radio Supply Co. Daily ex Sun, 8-8:30 pm, music. Sun, 8:30-4:30 pm, concert. Mountain.

CFCN, Calgary, Alta., Can. 275, 440 meters. 1,500 mi. W. W. Grant Radio Ltd. Slogan "Voice of the Prairies." Mon, 9 pm, Thurs, 10:30-12:30 pm, dance music. Sat, 10-12 pm. Wed, Sat, Sun, after 11:30 pm using test call 9AC. Mountain.

CFCL, London, Ont., Can. The London Advertiser.

CFCC, Fort Frances, Ont., Can. International Radio Develop. Co.

CFTC, Toronto, Ont., Can. The Bell Telephone Co. Licensed only.

CFYC, Vancouver, B. C., Can. Victor Wentworth Odium.

CHBC, Calgary, Alta., Can. 410 meters. 1,000 mi. W. W. Grant Radio Ltd. (Morning Albertan.) Daily ex Sat, 8:45-9:45 pm, news, stock quotations, music. Mountain.

CHCA, Vancouver, B. C., Can. Radio Corp. of Vancouver. No regular program.

CHCB, Toronto, Can. Marconi Co. No regular program.

CHCF, Winnipeg, Man., Can. Radio Corp. of Winnipeg, Ltd.

CHCS, London, Ont., Can. London Radio Shoppe.

CHCX, Montreal, Que., Can. B. L. Silver.

CHYC, Montreal, Que., Can. 410 meters. 1,500 mi. Northern Elec. Co. No regular schedule.

CHXC, Ottawa, Ont., Can. 450 meters. 50 mi. J. R. Booth, Jr. Mon, Wed, 8:30-11 pm, music, entertainment. Eastern.

CJBC, Montreal, Que., Can. 420 meters. 75 mi. Dupuis-Freres. Wed, Fri, 9-10 pm, music. Eastern.

CJCA, Edmonton, Alta., Can. 450 meters. 1,000 mi. Edmonton Journal, Ltd. Daily ex Sun, 12:30 pm, weather, markets; 2:30-8 pm, children's hour. 8:30-9:30 pm, concert, reports. Mountain.

CJCB, Nelson, B. C., Can. 400 meters. 100 mi. James Gordon Bennett. Daily, 8-9 pm, music, news, reports. Pacific.

CJCD, Toronto, Canada. 410 meters. 200 mi. T. Eaton Co. No regular program.

CJCE, Vancouver, B. C., Can. 420 meters. 150 mi. Vancouver Sun. Daily ex Sun, 8-10, music, news. Pacific.

CJCH, Toronto, Ont., Can. United Farmers of Ontario. St. John, N. B., Can. 400 meters. 75 mi. McLean, Holt & Co., Ltd. Daily, 8-9 pm, music, news, weather. Eastern.

CJCN, Toronto, Ont., Can. Simons, Agnew & Co. Licensed only.

CJCS, Halifax, N. S., Can. Eastern Telephone & Telegraph Co.

CJCY, Calgary, Alta., Can. Edmund Taylor.

CJCG, London, Ont., Can. 430 meters. 800 mi. London Free Press. Daily ex Sun, 12:30-1:30 pm, news, weather. Daily ex Tues, 7-7:45 pm, music. Tues, 7:30-8:30 pm, special program. Eastern.

CJNC, Winnipeg, Man., Can. 400 meters. 1,000 mi. Tribune Newspaper Co. Daily ex Sun, 1-2 pm, Tues, 8-10 pm, Thurs, 7-8 pm, Fri, 8-10. Alternate Sun, 8:30-10 pm. Central.

CJSC, Toronto, Ont., Can. Evening Telegram. Licensed only.

CKAC, Montreal, Que., Can. 430 meters. 1,000 mi. La Presse. Daily ex Sun, 2 pm, 3:30, weather, news, markets. 5-5:15, music. Tues, Thurs, Sat, 7-7:30 pm, bedtime stories; 7:30-10 concert, Sun 4-5:30 pm, music. Eastern.

CKBC, Winnipeg, Man., Can. T. Eaton Co. Ltd.

CKCE, Toronto, Ont., Can. Can. Ind. Telephone Co.

CKCK, Regina, Sask., Can. 420 meters. 1,500 mi. Leader Pub. Co. Daily ex Sun, 10-10:30 am, news, music; 1:15-2 pm, reports, music. Mon, Wed, Fri, Sat, 7:30-8:15, music. Tues, 7:30-9 concert. Sun, 9 pm, sacred concert. Mountain.

CKCR, St. John, N. B., Can. 400 meters. 75 mi. Jones Elec. Radio Co., Ltd. Daily 4-5 pm, concert, reports. Eastern.

CKKC, Toronto, Ont., Can. Radio Equipment & Supply Co. Ltd. Licensed only.

CKDC, Hamilton, Ont., Can. 410 meters. 100 mi. Wentworth Radio Supply Co., Ltd. Mon, Wed, Fri, 8:30-9:30 pm, concert. Sun, church services. Eastern.

CKCC, London, Ont., Can. 410 meters. 50 mi. Radio Supply Co. Mon, Wed, Fri, 7:30-8:30 pm, music, entertainment. Eastern.

CKCY, Winnipeg, Man., Can. 450 meters. 500 mi. Manitoba Tel. Co. Daily ex Sun, 12:30-1:30 pm, news, music; 1:45-2:00 pm, markets. Tues, Thurs, Fri, 8:30-10 pm, concert. Sun, 9-9:45 pm, concert.

CKCZ, Winnipeg, Man., Can. Salton Radio Eng. Co. D55, Denver, Colo. 360 meters. 1,500 mi. Fitzsimmons Gen. Hospital. Mon, Wed, Fri, 8-9 pm, music. Mountain.

DM4, San Antonio, Tex. 360 meters. 1,500 mi. U. S. Army. Kelly Field. No regular schedule.

DN4, Denver, Colo. 360 meters. 200 mi. Colorado National Guis. Daily ex Sun, 8:15 pm, weather, news, concert. Thurs, 8:15-9:30 pm, special concert, speech. Mountain.

KDKA, E. Pittsburgh, Pa. 360 meters. 2,000 mi. Westinghouse Elec. & Mfg. Co. Daily ex Sun, 10-10:15 am, 12:30-1 pm, music; 6-55 pm, news features, markets, concert; 9:55-10, time. Sun, 10:45 am, church service; 2:45 pm, Bible story; 3 pm, concert; 4:45 pm, 7:30, church service. Eastern.

KDDW, New York, N. Y. S.S. America. Home port is New York.

KDPM, Cleveland, O. 270 meters. Westinghouse Elec. & Mfg. Co.

KDPT, San Diego, Calif. 360 meters. 500 mi. Southern Elec. Co. Daily ex Sun, 7-7:30 pm, news, weather, concerts, lectures. Tues, Sat, 8-10 pm. Pacific.

KDYL, Salt Lake City, Utah. 360 meters. 1,800 mi. Salt Lake Telegram. Daily ex Sun, 7-8 pm, news, music, entertainment. Mountain.

KDYM, San Diego, Calif. 252 meters. Savoy Theater.

KDYQ, Portland, Ore. 360 meters. 200 mi. Oregon Institute of Technology. Tues, 9-10 pm, educational lectures, music. Pacific.

KDYS, Great Falls, Mont. 360 meters. 1,000 mi. Great Falls Tribune. Mon, Wed, Sat, 8-10 pm, concert. Sun, 4 pm, church services. Mountain.

KDYW, Phoenix, Ariz. 360 meters. 100 mi. Smith Radio & Co. Daily ex Sat, 7-7:30 pm. Mountain.

KDXX, Honolulu, T. H., Hawaii. 360 meters. 500 mi. Honolulu Star-Bulletin Co., Ltd. Daily ex Sun, 12:15-1:15 pm, reports; 6:30-7:30 pm, entertainment, music, talks. Sun, 11 am-12:15 pm, church services. Mountain.

KDZB, Bakersfield, Calif. 360 meters. 500 mi. Frank Siefert. Daily ex Sun, 8-9 pm, reports, music. Sun, sacred program, irregular. Pacific.

KDZE, Seattle, Wash. 360 meters. 500 mi. Seattle Radio Assn. Daily ex Sun, 10:30-11 am, 3:30-4:30 pm, news, music. Mon, Fri, 7-8 pm, concert. Wed, 8-9 pm, concert. Pacific.

KDZF, Los Angeles, Calif. 278 meters. Automobile Club of Southern California.

KDZG, San Francisco, Calif. 360 meters. Cyrus Pierce & Co.

KDZI, Wenatchee, Wash. 360 meters. 700 mi. Elec. Supply Co. Daily ex Sun, 4:30-5:30 pm, music. Mon, Wed, Fri, 8-9 pm, music. Sun, 11 am-12:30 pm, church services. Pacific.

KDZK, Reno, Nev. 360 meters. 50 mi. Nevada Machine & Elec. Co. (Nevada State Journal). Sun, 7-8 pm. Pacific.

KDZQ, Denver, Colo. 360 meters. Pyle & Nichols.

KDZR, Bellingham, Wash. 263 meters. 200 mi. The Bellingham Pub. Co. Mon, Wed, Fri, 7-8:30 pm, music, news, reports; 7:30-7:45, code practice. Tues, Sat, Sun, 7-8 pm. Pacific.

KDZT, Seattle, Wash. 360 meters. Seattle Radio Assn.

KFAD, Phoenix, Ariz. 360 meters. 200 mi. McArthur Brothers. Daily ex Sun, 7:30-8:30 pm, news, weather, stock reports. Mountain.

KFAE, Pullman, Wash. 360 meters. 1,500 mi. State College of Washington. Mon, Wed, Fri, 7:30-9 pm, lectures, music, readings. Pacific.

KFAF, Denver, Colo. 360 meters. 1,500 mi. Western Radio Corp. Slogan, "Voice from the Rockies—Out Where the West Is." Daily ex Wed and Sun, 8-9 pm, music, reports, news. Mountain.

KFAJ, Boulder, Colo. 360 meters. 800 mi. Univ. of Colo. No definite schedule. Univ. activities. Mountain.

KFAN, Moscow, Ida. 360 meters. 200 mi. The Electric Shop. Tues, Thurs, Sat, 7:30-8:30 pm, music, reports. Sun, church services. Pacific.

KFAP, Butte, Mont. 360 meters. Standard Pub. Co.

KFAQ, San Jose, Calif. 360 meters. City of San Jose.

KFAR, Hayward, Calif. 360 meters. Studio Lighting Service Co.

KFAT, Eugene, Ore. 275 meters. 100 mi. Pac. Radio Co. Mon, Wed, Sat, 8-9 pm, lectures, music. Pacific.

KFAU, Boise, Ida. 270 meters. 200 mi. Boise H. S. Daily ex Sun, 2-3:30 pm, markets, news; 8:30 pm, weather. Tues, Fri, 8-9 pm, concert. Thurs, 7:30-8:15 pm, music. Mountain.

KFAV, Venice, Calif. 258 meters. 50 mi. Abbot-Kinney Co. Mon, Tues, Wed, Fri, 8:30-9:30 pm, music. Pacific.

KFAW, Santa Ana, Calif. 360 meters. 100 mi. Radio Den. Daily ex Sun, 4-4:30 pm, news, reports, music. Mon, Thurs, 6:30-7:30 pm, concert. Pacific.

KFAY, Medford, Ore. 360 meters. 500 mi. Virgin Radio Service. Temporarily discontinued.

KFBB, Havre, Mont. 360 meters. 150 mi. F. A. Buttrely Co. Daily ex Sun, 12:30 pm, agriograms,

thedral. Sun, 11:15-12:30 pm, 8-9:15 church services. Mountain.

KDFD, Casper, Wyo. 360 meters. 600 mi. Wyoming Radio Corp. Daily ex Sun, 12:30 pm, weather, stocks. Wed, Fri, 8-9 pm, music. Sun, 8-9 pm, sacred music; 11-11:30, music. Mountain.

KDFH, Tucson, Ariz. 360 meters. 200 mi. Univ. of Ariz. Tues, Thurs, 7:30-8:30 pm, music, lecture, reports. Mountain.

KFDJ, Corvallis, Ore. 360 meters. Oregon Agri. College.

KFDL, Denver, Colo. 360 meters. Knight-Campbell Music Co.

KFDO, Bozeman, Mont. 360 meters. H. Everett Cutting.

KFDP, Des Moines, Iowa. 278 meters. 300 mi. Hawkeye Radio & Supply Co. Daily ex Sun, 3-3:45 pm, reports, music. Mon, 8-11 pm, music. Thurs, 9-11 pm, music, entertainment. Central.

KFDR, York, Neb. 360 meters. Bullock's.

KFDS, San Francisco, Calif. 360 meters. John D. McKee.

KFDU, Lincoln, Neb. 240 meters. Neb. Radio Elec. Co.

KFDV, Fayetteville, Ark. 360 meters. 300 mi. Gilbrech & Stinson. Slogan, "Southern Gateway to the Ozarks." No regular schedule. Central.

KFEM, Shreveport, La. 360 meters. First Baptist Church.

KFDY, Brookings, S. D. 360 meters. S. D. State College of Agri. & Mech. Arts. Mon, Sat, 8:30 pm, music. Tues, Thurs, 11 am, music, lectures, news. Central.

KFHZ, Minneapolis, Minn. 360 meters. Harry O. Iverson.

KFEB, Taft, Calif. 360 meters. 200 mi. City of Taft. Mon, Wed, Fri, 6:15-7 pm, music, news. Pacific.

KFEC, Portland, Ore. 360 meters. 25 mi. Meier & Frank Co. Inc. Daily ex Sun, 12 m, weather, reports; 4-5 pm, music; 6:30 pm, markets, reports. Thurs, 9-10 pm, concert. Sat, 11 am 12 m, children's hour. Pacific.

KFEJ, Tacoma, Wash. 360 meters. Guy Gresson.

KFEL, Denver, Colo. 360 meters. Winner Radio Corp. Daily ex Sun, 9 am, 10, 11, 11:45, stock reports; 3-4 pm, music. Mon, Fri, 9-10 pm, 12-1 am, concerts. Sun, 9-10 am, church services. Mountain.

KFEP, Denver, Colo. 240 meters. Radio Equipment Co.

KFEQ, Oak, Neb. 360 meters. J. L. Scroggin.

KFER, Fort Dodge, Ia. 251 meters. Auto Electric Service Co.

KFHF, Shreveport, La. 266 meters. Central Christian Church.

KFHH, Neah Bay, Wash. 283 meters. Ambrose A. McCre.

KFHI, Wichita, Kans. 224 meters. Charles V. Dixon.

KFJJ, Santa Barbara, Calif. 360 meters. Fallon Company.

KFHL, Oskaloosa, Ia. 227 meters. Penn College.

KFHP, Kearney, Neb. 246 meters. Radio Bug Products Co.

KFHR, Seattle, Wash. 270 meters. Star Elec. & Radio Co.

KFI, Los Angeles, Calif. 469 meters. 2,000 mi. Earl C. Anthony. Inc. Daily ex Sun, 1-1:30 pm, 5-6 pm, 7-8:30 pm, 8-11 pm. Sun, 10:30-11:30 am, 4-5 pm, 8-11. Pacific.

KFIB, St. Louis, Mo. 224 meters. Franklin W. Jenkins.

KFIC, Denver, Colo. 224 meters. Phillip Laskowitz.

KFID, Iola, Kan. 246 meters. Ross Arbuckles Garage. Mon, Thurs, Sat, 7:30-8 pm. Central.

KFIF, Portland, Ore. 360 meters. Benson Tech. Student Body.

KFIJ, Platte, S. D. 236 meters. Sidney I. Thorsan.

KFIK, Gladbrook, Iowa. 234 meters. Gladbrook Elec.

KFIO, Spokane, Wash. 252 meters. North Central High School.

KFIQ, Yakima, Wash. 224 meters. 200 mi. Yakima Valley Broadcasting Assn. Slogan, "The Station That Will Make 224 Famous." Daily ex Sun, 7:30-8 pm, weather, markets. Mon, Fri, 8-9 pm, concert. Pacific.

KFJD, Greeley, Colo. 236 meters. Weld County Printing & Pub. Co.

KFKH, Lakeside, Colo. 226 meters. Denver Park Amusement Co.

KFZ, Spokane, Wash. 283 meters. 300 mi. Doerr-Mitchell Elec. Co. Slogan, "In the Heart of the Inland Empire." Tues, Fri, 7:30-9 pm, music. Sun, 6-7 pm. Pacific.

KGB, Tacoma, Wash. 360 meters. 200 mi. Tacoma Daily Ledger—William A. Mullins Elec. Co. Daily ex Sun, 7-9 pm. Sun, 5-7:30 pm, entertainment. Pacific.

KGG, Portland, Ore. 360 meters. 500 mi. Hallock & Watson Radio Service. Slogan, "The Rose City." Daily ex Sun, 5-6 pm, music, entertainment 7:30-8 pm, reports. Sat, 8-9 pm, answers to Radio questions. Sun, Wed, 9-10 pm, music. Pacific.

KGN, Portland, Ore. 360 meters. 100 mi. Northwestern Radio Mfg. Co. Irregular schedule.

KGO, Altadena, Calif. 360 meters. 300 mi. Altadena Radio Lab. No regular schedule.

KGU, Honolulu, Hawaii. 360 meters. 150 mi. The Honolulu Advertiser. Daily 7:30-9 pm, Tues, Thurs, Sat, special program. 150th meridian. (Three hours later than Pacific.)

KGW, Portland, Ore. 492 meters. 1,500 mi. Oregonian Pub. Co. Slogan, "KGW, Keep Growing Wiser." Daily ex Sun, 1:30 am, weather; 3:30-4 pm, woman's program; 7:30 pm, weather. Mon, Wed, Fri, 8-9 pm, concert. Mon, Fri, 7-7:30 pm, lecture; 11-12 pm, Hoot Owls. Sun, 7-8 pm, concert. Pacific.

KGV, Lacey, Wash. 258 meters. 250 mi. St. Martins College. Slogan, "Out Where the Cedars Meet the Sea." Tues, Fri, Sun, 8:30-9:30 pm, news, concert, lecture, bedtime story. Pacific.

KHJ, Los Angeles, Calif. 395 meters. 2,000 mi. Los Angeles Times. Daily ex Sun, 12:30-1:15 pm, 6:45-7:30, 8-10, Sun, 10-11 am, 8-10 pm. Pacific.

KHQ, Seattle, Wash. 360 meters. Louis Wasmser.

KJJ, Sunnyvale, Calif. 360 meters. 500 mi. Radio Shop. Tues, 8:15-9 pm, Fri, 7:30-8:15 pm. Pacific.

KJQ, Stockton, Calif. 360 meters. 100 mi. Gould, The Light Man. Daily ex Sun, 5-6 pm, concert. Mon, Wed, 9-10 pm, concert. Sun, 10-11 am, church services. Pacific.

KJR, Seattle, Wash. 270 meters. 1,500 mi. Northwest Radio Service Co. Daily ex Sun, 5:30-6:15 pm, reports. Mon, 7:30-8:30 pm, music. Tues, Fri, Sat, 8:30-9:30 pm, concert, lecture, bedtime stories. Thurs, 9-10:30 pm, Pacific.

KJS, Los Angeles, Calif. 360 meters. 100 mi. Bible Inst. of Los Angeles. Tues, 7-7:30 pm, Thurs, 8-9, sacred music, lectures, etc. Sun, 11:30-12:30 pm, 6-6:45, 8-9, church services. Pacific.

KKL, Los Angeles, Calif. 360 meters. Monterey Elec. Shop. Daily, 12-1 pm, weather, markets, news; 7-8 pm, concert. Tues, Fri, 7-7:30 pm, 8-8:30, concert. Pacific.

KLS, Oakland, Calif. 360 meters. 1,500 mi. Warner Bros. Radio Supply Co. Daily, 11:30-1 pm. Fri, 8-9 pm. Sun, 12-1 pm. Pacific.

KLX, Oakland, Calif. 360 meters. 500 mi. Oakland Tribune. Daily ex Sun, 3:15-5:15 pm, sports; 7-7:30, news, entertainment. Tues, 8-9 pm. Fri, 9-10 pm. Sun, 10-11 am, church services. Pacific.

KLZ, Denver, Colo. 360 meters. 70 mi. Reynolds Radio Co. Daily ex Sun, 7:30-8 pm, news, markets, bedtime story. Thurs, 8-9 pm, concert. Sun, 8:30-10:30 pm, concert. Mountain.

KMJ, Fresno, Calif. 360 meters. 300 mi. San Joaquin Lt. & Pr. Corp. Tues, Fri, 8-9 pm, music. Sun, 5-6 pm, music. Pacific.

KMO, Tacoma, Wash. 360 meters. 200 mi. Tacoma Times. (Love Electric Co.) Daily ex Sun, 6-7 pm, 9:15-10, concert, news, lecture. Pacific.

KML, Eureka, Calif. 360 meters. T. W. Smith.

KNL, Los Angeles, Calif. 360 meters. 100 mi. Bullock's. Temporarily discontinued.

KNT, Aberdeen, Wash. 263 meters. 600 mi. Grays Harbor Radio Co. Daily ex Sun, 7-8 pm, news, concert. Pacific.

KNV, Los Angeles, Calif. 360 meters. Radio Supply Co.

KNX, Los Angeles, Calif. 360 meters. Elec. Lighting & Supply Co.

KDB, State College, N. M. 360 meters. 500 mi. N. M. Agri. & Mech. Arts. Daily 11:55-12 m, 9:55-10 pm, time, reports. Mon, Wed, Fri, 7:30-8:30 pm, concert. Mountain.

KOP, Detroit, Mich. 286 meters. 1,500 mi. Detroit Police Dept. Slogan, "Safety First." Daily ex Sun, 1 pm, 6:30, reports, police information, emergency. Eastern.

KPO, San Francisco, Calif. 423 meters. 1,500 mi. Hale Bros., Inc. Daily ex Sun, 4:30-5:15 pm, music, Tues, Thurs, Sat, 8-10 pm, concert, lectures. Sun, 11-12:30 pm, church services. Pacific.

KQL, Berkeley, Calif. 360 meters. Univ. of Calif.

KQP, Hood River, Ore. 360 meters. Apple City Radio Club. Slogan, "Apple City of the West." Daily ex Sat, Sun, 6 pm, news. Mon, Wed, Fri, 6:30 pm, music. Wed, 9 pm, special. Pacific.

KQV, Pittsburgh, Pa. 360 meters. 300 mi. Doubleday-Hill Elec. Co. Daily ex Sun, 12-12:30 pm, 4:30-5, music. Mon, Wed, Fri, 10-10:55 pm, concert. Fri, 4:30-5:15 pm, children's program. Eastern.

KQW, San Jose, Calif. 360 meters. 500 mi. Chas. D. Herold. Daily ex Sun, 1-1:30 pm, Wed, 8-9 pm, concert. Pacific.

KRE, Berkeley, Calif. 360 meters. 600 mi. Maxwell Elec. Co. Mon, 8-10 pm, Wed, 9-10 pm, concert. Pacific.

KSD, St. Louis, Mo. 546 meters. 1,500 mi. St. Louis Post Dispatch. Daily ex Sun, 8:40 am, 9:40, 10:40, 11:40, 12:40 pm, 1:40, 2:40, 4, 8. Thurs and Sun, silent nights. Mon, Fri, 11:30 pm, concerts. Central.

KSL, San Francisco, Calif. 360 meters. 50 mi. The Emporium. Temporarily discontinued.

KSS, Long Beach, Calif. 229 meters. Prest & Dean Radio Co. No regular schedule.

KTW, Seattle, Wash. 360 meters. 500 mi. First Presbyterian Church. Sun, 11-12:30 pm, 3-4:30, 7-9:30, church service. Pacific.

KUO, San Francisco, Calif. 360 meters. 1,500 mi. San Francisco Examiner. Slogan, "The Voice of the West." Daily ex Sun, 9-10 am, concert, chat to housewives; 11-12, reports; 2:30-3:30 pm, lecture, news; 9 am, 12 m, 6:45 pm, weather reports. Sun, 9-10 am, 3-5 pm, news. Pacific.

KUS, Los Angeles, Calif. 360 meters. 300 mi. City Dye Works & Laundry Co. Daily ex Sun, 7:30 am, setting up exercises; 12-12:30 pm, concert, time. Mon, Thurs, Fri, 2-2:30 pm, features. Tues, Fri, 4-4:30 pm, code practice. Wed, Fri, 6-6:45 pm, concert. Pacific.

Serially Continuously—

THE BROADCASTING station directory is the most complete and authentic list of Radiophone plants. Letters are being sent various stations every day for information. No other paper or source provides the data given here. The idea is original and a service which Radio Digest has maintained from the start. Every public service broadcasting station is to be found now, not only in the location index, but in the schedule list. The latter, however is divided, one-fourth appearing this week, the second quarter to appear next week, and the third part the week following and the fourth will have the state, city and station index.

The station schedules given here are listed alphabetically by call letters. Following the call is given the city and state, the wave length, estimated sure miles range of the station, the owner's name, the slogan of the station if one is used, name of listener in "club," the schedule of operating hours, and the kind of time used.

The state, city and call list appears with the last week and is merely an index. One wishing to find the calls of the stations in his vicinity, will find this index useful. Three successive issues of Radio Digest will give one the most complete and accurate list of broadcasting stations obtainable.

weather, news. Tues, Fri, 8-9:30 pm, music. Mountain.

KFBG, San Diego, Calif. 278 meters. 500 mi. W. K. Azbill. Thurs, Sun, 8-9 pm, Bible lesson, sermon. Pacific.

KFBD, Hanford, Calif. 360 meters. 200 mi. Clarence V. Welch. Mon, Wed, 3-4 pm, 7:30-8:30, news, music, agriograms. Tues, Thurs, Sat, 6-7 pm, music. Fri, 3-4 pm, 9-10, news, music. Sun, 7-8 pm, church services. Pacific.

KFBE, San Luis Obispo, Calif. 360 meters. 500 mi. R. H. Horn. Mon, Wed, Fri, 4-5 pm. Wed, Fri, 7-7:30 pm. Pacific.

KFBG, Tacoma, Wash. 360 meters. First Presbyterian Church.

KFBH, Marshfield, Ore. 360 meters. Thomas Musical Co.

KFBK, Sacramento, Calif. 283 meters. 300 mi. Kimball-Sacramento Co. Slogan, "Heart of California." Daily ex Sun, 6-6:45 pm, concert, news, codes. Wed, 8-9:30 pm, concert. Sun, 10-11 am, church service; 8-9 pm, concert. Pacific.

KFBL, Everett, Wash. 224 meters. 50 mi. Leese Bros. Daily ex Sun, 7:15-8:15 pm. Sun, 2-3 pm. Eastern.

KFBS, Trinidad, Colo. 360 meters. Chronicle News & Agri. & Elec. Supply Co.

KFBU, Laramie, Wyo. 360 meters. Bishop N. S. Thomas.

KFCB, Phoenix, Ariz. 360 meters. 500 mi. Nielsen Radio Supply Co. Mon, Wed, Fri, 8-9 pm, music. Tues, 8-10, sports. Mountain.

KFCD, Salem, Ore. 360 meters. 100 mi. F. S. Barton. Tues, Wed, Fri, 7-8 pm. Pacific.

KCFE, Walla Walla, Wash. 360 meters. Frank A. Moore.

KCFH, Billings, Mont. 360 meters. 500 mi. Electric Service Station Inc. Wed, Fri, Sun, 7:30-9 pm, music. Mountain.

KFCR, Colorado Springs, Colo. 360 meters. Colorado Springs Radio Co.

KFCL, Los Angeles, Calif. 360 meters. 1,500 mi. Los Angeles Union Stock Yards. Daily ex Sun, 10-10:30 am, 12-12:30 pm, 4-4:30, 8-8:20, live stock reports. Pacific.

KFCM, Richmond, Calif. 244 meters. 500 mi. Richmond Radio Shop. Slogan, "Out Where the West Ends." Daily ex Sun, 1-2 pm, music. Tues, Fri, 8-9 pm, music. Pacific.

KFCP, Ogden, Utah. 360 meters. Ralph W. Flygare.

KFCV, Houston, Tex. 360 meters. 300 mi. Fred Mahaffey, Jr. Daily ex Sun, Mon, 7:30-8 pm, markets, entertainment. Sun, 2-3 pm, entertainment. Central.

KFCY, Le Mars, Ia. 360 meters. 300 mi. Western Union College. Fri, 8-9 pm, music, educational. Central.

KFZO, Omaha, Neb. 360 meters. Omaha Central H. S.

KFAK, Baker, Ore. 360 meters. 25 mi. Adler's Music Store. Daily ex Sun, 5-6 pm, 7-8, music. Sun, 6-8 pm. Pacific.

KFDB, San Francisco, Calif. 509 meters. 1,500 mi. Mercantile Trust Co. Daily ex Sun, 10-11 am, weather, markets; 11-11:30, news, quotations; 2-3 pm, lectures, concerts. Mon, Wed, Fri, 8-10 pm, concert. Sun, 7-7:30 pm, children's stories. Pacific.

KFDC, Spokane, Wash. 285 meters. 25 mi. E. B. Craney. Temporarily discontinued.

KFDD, Boise, Idaho. 360 meters. St. Michael's Ca-

KFEV, Douglas, Wyo. 263 meters. 250 mi. Felix Thompson Radio Elec. Shop. Weather reports and special warnings. Mountain.

KFEX, Minneapolis, Minn. 286 meters. 600 mi. Augsburg Seminary. Mon, Wed, Fri, 10:30 am, chapel. Tues, Sat, 5 pm, music. Sun, 9:15 pm, church services. Central.

KFEY, Kellogg, Ida. 360 meters. Bunker Hill & Sullivan Mining & Const. Co.

KFEZ, St. Louis, Mo. 360 meters. American Society of Mech. Engrs.

KFFA, San Diego, Calif. 244 meters. 200 mi. Dr. R. O. Shelton. Daily, 6-7 pm, entertainment. Pacific.

KFFB, Boise, Ida. 360 meters. 70 mi. Jenkins Fourn. Co. (Owyhee Hotel). Daily, 8-9 pm, concert. Mountain.

KFFE, Pendleton, Ore. 360 meters. 100 mi. Eastern Ore. Radio Co. Daily ex Sun, 8:30-9:30 pm, music. Pacific.

KFFG, Hillsboro, Ore. 360 meters. Dr. E. H. Smith.

KFFP, Moberly, Mo. 275 meters. 300 mi. First Baptist Church. Slogan, "The Gospel Messenger of the Air." Sun, 10:45 am, 8 pm, church services. Central.

KFFQ, Colorado Springs, Colo. 360 meters. 250 mi. The Markshel Motor Co. Daily, 8:15 am, weather; 4-5 pm, concert. Mon, Wed, Fri, 9-9:30 pm, special program. Mountain.

KFFR, Sparks, Nev. 360 meters. 50 mi. Jim Kirk. Daily ex Sat, Sun, 3:30-4 pm, entertainment. Mon, 10-11 pm, special. Pacific.

KFFS, Lamoni, Ia. 360 meters. Graceland College.

KFFX, Omaha, Neb. 278 meters. 600 mi. The McGraw Co. Daily, 2:30-3:50 pm. Central.

KFFY, Alexandria, La. 360 meters. Pincus & Murphy, Inc.

KFFZ, Dallas, Tex. 360 meters. Al G. Barnes. Amusement Co.

KFGB, Pueblo, Colo. 360 meters. Lowenthal Bros.

KFGC, Baton Rouge, La. 254 meters. Louisiana State University. No regular schedule.

KFGD, Chickasha, Okla. 360 meters. Chickasha Radio & Elec. Co.

KFGE, Stanford Univ., Calif. 360 meters. 500 mi. Leland Stanford Junior University. No regular schedule.

KFGJ, St. Louis, Mo. 266 meters. National Guards Missouri.

KFGK, Arlington, Ore. 234 meters. Arlington Garage.

KFGP, Cheney, Kans. 229 meters. Cheney Radio Co.

KFGQ, Boone, Ia. 226 meters. Cray Hardware Co.

KFGV, Utica, Neb. 224 meters. 50 mi. Heibredner Radio Supply Co. No regular schedule.

KFGR, Orange, Tex. 250 meters. First Presbyterian Church. Sun, 11 am, 7:30 pm, church services. Central.

KFGY, Baudette, Minn. 224 meters. Gjelhaug's Radio Shop.

KFGZ, Berrien Springs, Mich. 268 meters. Emanuel Missionary College.

KFHA, Gunnison, Colo. 360 meters. Colorado State Normal School. "Where the Sun Shines Every Day." Daily ex Sun, 8:30 am, weather, markets. Tues, 7:30 pm, entertainment. Mountain.

KFHB, Hood River, Ore. 280 meters. P. L. Boardwalk.

KFHD, St. Joseph, Mo. 226 meters. 50 mi. Utz Electric Co. Slogan, "Where the Mountains Meet the Sea." Daily ex Sun, 5:30-6 pm. Mon, Thurs, Sat, 8-9:30 pm, concert. Central.

(NOTE—The second part of the station schedule list will appear next week.)

ADVANCE PROGRAMS

(Continued from page 7)

Organ recital, Mary E. Vogt; 12:00-12:55 P. M., Luncheon music, Tea Room Orchestra; 4:45-5:00 P. M., Organ recital, Mary E. Vogt; 7:45-9:00 P. M., Concert, WGO Orchestra, Robert E. Golden, director; 9:30 P. M., Organ recital, Mary E. Vogt.

Saturday, June 23

CFA (Eastern, Daylight Saving, 400), 8:00-9:00 P. M., Musical program, Selection from "H. M. S. Pinafore," Star Orchestra, Ernest Morgan, baritone; "Valse Bluette," Orchestra; "Until the Dawn," W. Woods, cornetist; Ernest Morgan, baritone; "Peer Gyn," Orchestra; "Nocturne in E Flat," Harry Adaskin, violinist; Ernest Morgan, baritone; "Mignonette," "Russian Serenade," Orchestra.

Sunday, June 24

WBAP (Central, 476), 11:00-12:15 P. M., Church services, First Methodist Church, Rev. J. W. Bergin, pastor.

Monday, June 25

WBAP (Central, 476), 9:30-10:30 P. M., Concert, Rambler's Orchestra.

PATENT ATTORNEYS

PATENTS. Booklet free. Highest references. Best results. WATSON E. COLEMAN, Patent Lawyer, 624 F Street, Washington, D. C.

RADIOPHANS

We are manufacturers of SAILS for CANOES and BOATS & YACHTS and Spray Hoods. Write for Prices and Information LOUIS J. LARSON, 45 Fulton St., N. Y. C.

body Else," Roger Hill Dance Orchestra; Walter Phillips, baritone; "Gypsy Lady," "Japanese Lullaby," "Please Don't Talk About Me When I'm Gone," Orchestra; Walter Phillips Orchestra, S. A. I. Trio; Songs, Eleanor W. Mackay; "Sourvenir," "Guitarrero," Lucy R. McKeever, violinist; S. A. I. Trio.

SPECIAL OFFER LIST

(Continued from page 2) tance Switch; 1 Martin-Copeland 11-Point Inductance Switch; Walnart Variable Grid Leak with .00025 mfd. Condenser; Walnart Variable Condenser (3-plate .00096 mfd.); Ray-O-Vac Dry Battery, 2 cells 1.14 vfd.; Dubilier Ducon; Dubilier Micadon Type 600 (.006 mfd.); Dubilier Micadon Type 610 (.01 or .02 mfd.); Dubilier By-Pass Condenser (1 mfd.), Premier Universal Radio Jack, Filament Control Five Spring; CRL Variable Grid Leak, without condenser; Premier No. 250 Variable Resistance, panel mounting.

Class D Articles For eight consecutive coupons and one dollar and twenty cents (\$1.20) any one of the following articles will be sent: 1 Carter 20-Ohm Vernier Control Rheostat; 1 Schindler Radio Frequency Transformer; 1 Martin-Copeland 13-Point Inductance Switch; 1 Martin-Copeland 15-Point Inductance Switch; 1 Martin-Copeland 19-Point Inductance Switch; Walnart Variable Condenser (5-Plate .0001 mfd.); Ray-O-Vac No. 4151 B Battery, 2 1/2 cells; Ray-O-Vac Dry Battery, 3 cells 4 1/2 volts; Electrad Variophon, with mica condenser; Dubilier By-Pass Condenser (.2 mfd.); CRL Variable Grid Leak with Condenser; Resistorometer (Type B) or 2A).

Class E Articles For ten consecutively numbered coupons and one dollar and fifty cents (\$1.50) any one of the following articles will be sent: 1 Carter 6-Ohm Automatic Control Rheostat; 1 Carter 20 Ohm Automatic Control Rheostat; 1 Decima 3-Plate Variable Condenser; Walnart Variable Condenser (13-Plate .00025 mfd.); Ray-O-Vac Dry Battery, 4 cells 1 1/2 volts; Dubilier Variodon (.0004 or .0006 mfd.); Resistorometer (Type B); Delta Midget Tube and Socket.

Class F Articles For twelve consecutively numbered coupons and one dollar and eighty cents (\$1.80) the following will be sent: 1 Acme Pot-Rheo (potentiometer and rheostat); Walnart Variable Condenser (23-Plate .0005 mfd.); Ray-O-Vac No. 4151 B Battery, 2 1/2 cells; Dubilier By-Pass Condenser (3 mfd.); Premier Variable Condenser without dial (.00039 mfd.).

Class G Articles For fourteen consecutively numbered coupons and two dollars and forty cents (\$2.40) any one of the following articles will be sent: 1 Federal 7-Plate Variable Condenser; 1 Federal 11-Plate Variable Condenser; 1 Federal 12-Plate Variable Condenser; 1 Federal Antic-capacity Switch; 1 Decima Variable Condenser 11-Plate Walnart Variable Condenser (43-Plate .001 mfd.); Dubilier Variodon (.001 mfd.); Dubilier By-Pass Condenser (4 mfd.); Premier Variable Condenser with dial (.00078 mfd.); Premier Hegehog A. F. Transformer, 4 to 2 Ratio.

Class H Articles For sixteen consecutively numbered coupons and three dollars (\$3.00) any one of the following articles will be sent: 1 Federal Audio Frequency Transformer No. 223 W; 1 Decima 23-Plate Variable Condenser; 1 Acme Audio Frequency Transformer; 1 Acme Radio Frequency Transformer (B-2, B-3, or B-4); Walnart Variable Condenser (13-Plate vernier); Walnart Variable Condenser (23-Plate vernier); Ray-O-Vac No. 2301 "B" Battery 4 1/2 volts; Ray-O-Vac Dry Battery, 6 cells 1 1/2 volts; Dubilier Duratron (B. F. transformer); Premier Micrometer Variocoupler with dial; Premier Variable Condenser with dial (.0015 mfd.); Premier Variable Condenser with vernier (.0004 mfd.); Premier Hegehog A. F. Transformer, 10 to 1 Ratio; Premier Hegehog A. F. Transformer, Tube Socket Type, 4 to 1 Ratio; Turney Spider Web Coil Mount, Type B.

Novel Lead-In Insulator

A piece of conduit 1/4-inch longer than the wall is thick and two condulets make

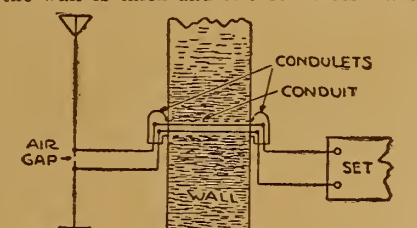

a very neat and efficient lead-in insulator. The diagram is self-explanatory.—Lloyd Johnson, Liberty, Ind.

There are nights rare in winter, and common in the summer, when it is impossible to bring in distant stations. This is due to atmospheric conditions beyond control. This condition should be met philosophically as something that cannot be avoided, and not used as the basis of a complaint to the Radio dealer who sold you your set.

For Perfect Reception You Must Use

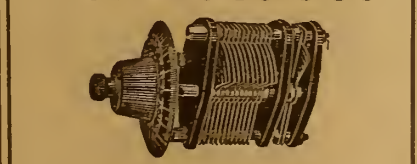

AMSCO Vernier Condensers

They satisfy the most exacting. Perfect spacing, permanent adjustment—finished in white nickel.

13 plate \$5.50 23 plate 6.00 43 plate 6.50 At All Good Dealers AMSCO PRODUCTS, INC. Broome & Lafayette Sts., New York City

The Reader's View

Talking Transformers

I have just read in the Digest for May 12 an article by a fan who, while presumably sane and sober, heard voices coming out of his box without the use of phones. If he is an ordinarily cautious man, he wrote you anonymously, or under the non de plume "Munhausen" to avert a visit from a Volstead squad or a lunacy commission; yet I'm perfectly ready to believe every word of his tale, for I, too, can pull the plug out of my Flewelling set and she goes right on talking. Don't shoot! I'll come down! The explanation, as I have doped it out, is ridiculously simple and obvious when you think of it. As surmised by the other fan, credit for the performance is due to an AF transformer, and I'll bet my last dollar (which is the only one the Radio dealers have left me) he has the same type of transformer as I, as only one kind will act in this manner.

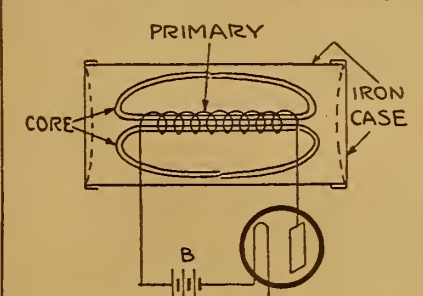

You get it now, don't you? The plate current simply magnetizes the core, which attracts and vibrates the circular ends of the case, or drum. These ends thus become, in effect, diaphragms and the transformer simply a double-end telephone.

My fellow-lunatic will find that, in all probability, this transformer couples his first and second stages, as the current from the detector tube is probably not powerful enough to vibrate these stiff disks audibly. He will also find that turning on the rheostat of the second stage will make the transformer "shut up," as this closes the secondary circuit in the transformer, allowing a current to be induced therein in the opposite direction from that passing through the primary coil, thus neutralizing the magnetizing effect of the primary on the core. Thus, a "loud speaking transformer" could be easily constructed, but the secondary would be useless; that is, the "do-dad" could not be used as a loud speaker and a transformer at the same time. So you see this fan and I simply have a very inefficient built in telephone—in effect because it was not designed for that purpose and the stiff case-ends work as diaphragms merely through what might be called coincidence.—L. B. Godbey, St. Louis, Mo.

FLEWELLING ANSWERS

By E. T. Flewelling

(Editor's Note.—This department is written by Mr. Flewelling, the inventor of the famous super circuit. From the questions sent him each week core of Radio Digest, he picks the one considered most informative for all and answers it in this column.)

Variable Condenser Too Large

(Submitted by T. Z., Jersey City, N. J.)

Question.—My Flewelling set is very selective and pretty loud, but I do not get the steady high pitched whistle when I have tuned in a station because I have to turn down the filament to reduce the whistle in order to bring in the station. Would the 43-plate variable condenser that I am using have any effect on this?

Answer.—Using a 43-plate condenser usually means utter failure with the Flewelling set, because the set tunes so sharply that one is unable to handle such a large sized condenser. Note also that the value given for the coils is such that maximum results are secured by the use of the smaller condensers such as a 7 to 11-plate. If only the values that have been given in the various articles are used, you will find that the rheostat is only useful to turn the filament off or on, and does not in any way aid in tuning. Change your condenser to a smaller one, turn your tube on full, and you will see that the whistle will stay even after the station is tuned in.

Directional Characteristics

When an inverted L-type antenna is used at a transmitting station and it is desired to radiate the greatest amount of energy in the direction of a particular station, the end at which the lead-in is connected is pointed in the direction of the station with which it is desired to communicate. The reason for this arrangement is that electromagnetic waves radiate more strongly from this end, thus providing directional characteristics which may be used to advantage.

Get a License First

In order to operate a transmitting station, two licenses must be obtained—an operators' license and a station license. The operator must be able to transmit and receive at least ten words a minute, each word consisting of five letters or characters. He must also comply with certain regulations detailed in the pamphlet issued by the United States Government entitled "Radio Communication Laws of the United States."

RITTER LOOP \$1.00 \$1.00. Diagram of a Ritter Loop antenna.

We are originators of the knock-down portable loop aerial. Packed in individual cartons. CONTENTS—Green silk covered wire, wood parts, binding posts and complete instructions on how to assemble and operate. By mail 10c extra. Ritter Radio Corp. 230 Canal Street NEW YORK

MANUFACTURER'S AGENTS

Wanted in leading cities for High Grade Products, nationally known and advertised. Sales last season over quarter million. State lines handled and territory.

BOX 21

Radio Digest, 123 W. Madison St., Chicago

1500 Miles On One Tube Set

Complete parts for Regenerative Receiver. We hear Havana, Cuba, regularly on this receiver. It consists of the following standard parts: 1 180° variocoupler, 1 23-plate variable condenser, 1 Howard socket, 1 Klossner vernier rheostat, 1 Fada switch lever, 1 1/2 switch points, 2 switch stops, 8 binding posts, 1 "49" bakelite panel, 1 mahogany cabinet, 2 3" dials, copper shield for panel, bus wire, tube Solder-all, and connecting diagram. \$12.85 Mailed Postpaid for \$17.95 Above outfit completely assembled and ready to "listen in." Mailed Postpaid for \$17.95

Summer Static Overcome



ANTENNELLA No aerial or antenna needed. Eliminates aerial, outside wiring, lightning arresters and other inconveniences inductive to static. Plug Antennella in any lighting socket and you can enjoy Radio in any room in your house. No current consumed.

New Improved Antennella NOW ONLY \$1.25 formerly \$2.00

At your dealer's—otherwise send purchase price and you will be supplied postpaid.

Chas. Freshman Co. Inc. Radio Condenser Products 106 SEVENTH AVE., NEW YORK

Radio Digest Illustrated

REG. U. S. PAT. OFF.

Published by the Radio Digest Publishing Company, Inc.
123 West Madison Street
Telephone State 4844-4845
Chicago, Illinois

E. C. RAYNER, Publisher
Chas. F. Smisor, Editor
Harry J. Marx, Technical Editor

Eastern Representative, Jacob Miller, Times Bldg., Times Square,
New York; Telephone Bryant 4909

Pacific Coast Representatives

E. J. Wood, 251 Kearney St., San Francisco
Telephone Kearney 1472

H. M. Morris, 417 Western Mutual Life Building, Los Angeles
Telephone 12011

58
PUBLISHED WEEKLY

SUBSCRIPTION RATES
Yearly.....\$5.00 Foreign.....\$6.00
Single Copies, 10 Cents

Vol. V Chicago, Saturday, June 23, 1923 No. 11



OUR vacation, wherever spent, offers a host of Radio possibilities. The man in the cool, northern wilderness, the person sojourning at any one of the small lake resorts, the individual who prefers to rest in the country; in fact, all are realizing the full service which their small receiving set can furnish. News, baseball scores, market reports, music, invisible drama, and the multitude of innovations already made possible by the thoughtfulness of studio directors, are all there for the tuning. With fifty super stations keeping the various sections of the country well supplied with broadcast service, it is indeed a poor set that cannot tune in several plants. Again, a set which can reach only one hundred miles out from a city home, is almost sure to do much better than that when installed in a small country town, out on a farm, at seaside, or in the mountains.



UTOMOBILE tours have had a great revival in interest since it has been demonstrated that one can keep in touch with the world by Radio, even while speeding along. The popularity of the passenger car has hardly had a slump, but the fact remains that the receiving of broadcasting stations en tour has added a new thrill to the jaded similarity of swallowing the unalaid dust of the car just ahead. An aerial around the top of the car, a loop, or even a hastily erected single wire to some nearby tree, plus a compact portable set equipped with dry cell tubes, make an unbeatable combination to fill in the leisure moments when the tourist has just about had his fill of holding the car on the road and wishes to rest. Then, too, the storage battery equipment of the average machine makes it very simple to use one's regular set with the larger tubes.



CAMPING out is a time-honored sport. From the time of the tribes of Israel, and thousands of years before that, the tent has been a shelter accepted by all. Thus we find many lovers of the great outdoors breaking away from the daily routine and making their home in a camp under the canvas spread of a tent where they can hear the bombardment of the rain pitter-patter and the call of the night birds. But add the marvel of the twentieth century to the scene. Easily erected, operated and maintained, a camper's portable set provides that contact and cheer of the busy world, but in the isolation of the wilderness. The tenderfoot may find camping boring at times, but Radio will give him the entertainment and news, the lack of which is troubling him. Certainly, your vacation will be with Radio. Why not?



RADIO INDI-GEST

FIRST WALLA WALLA PROGRAM

(Continued from where we were interrupted last week.) for this suspicious occasion.
Article C.—Bambdin Bray, chief head official announcer not emeritus will announce. After announcing all that he has to announce he will not announce any more until there's something more to announce. At present there is nothing to announce except that he will announce. (P.S.—Bambdin Bray, chief head official announcer, uses deaf and dumb sign language in all his announcing when he announces.)



Mr. Wattle Knees, musical director, walking south

Article D.—(Four and one-third coupons and a plugged jitney.) The first act to be broadcast. Le Moqueur and Ellis Broaklewse will tersichore a synthetic dance before the microphone. (Listen in for this. It's gonna be good.)

Article E.—Community Chorus. All listeners in will sing to the direction of Mr. Wattle Knees, Indigest's ultraordinary musical director. Wattle Knees will direct before the microphone with a muffed baton so that no noises will be made to destroy the great vast multitude of noises of our listeners in.

Article F.—Soft shoes dance by Polly W. and Rita M. Silent hobnail

army shoes have been ordered from the U. S. Steel Corp. for this momentous moment.

Article G.—Motion Picture, "Why Wallow in Walla Walla?" Scenario by Alagonquin Tonsils III; Filmed by Spider Webb; Misdirected by Lillian G.

Article H.—A trip through the Walla Walla Museum. A portable microphone will be carried throughout the entire length of this venerable hall so that all exhibits may be heard.

Article I.—Collection taking for \$000,000,000,000.19 to help pay off the victors in the Stebbins Degenerative Set Contest.

Article J.—None has been set inasmuch as this is the finale. All artists will gather before the microphone to smile and bow for the listeners in after which the antenna will be lowered by Mike and Izzy.



Bambdin Bray head announcer, and houncer

In Quest of the Kanoofis

Part II—In Italy

For days they searched the forests, no Kanoofis could be found. (Misery, don't pester me.) They hunted high and low for it, all over the ground. (Simply no luck.)

"It can't be here," said one of them, "Let's pack our things and go." (Merrily we roll along.)

"Where to? Ah, that's the question." Another said, "I know (Wise guy.)

"We'll go to sunny Italy, where the wild spaghetties grow. (Oh, Marie, my Marie.)

"And the hot Tomale bushes are blooming in a row. (Pretty flowers.)

"You're on!" they all exclaimed at once, "We're going to a clime. (Isn't it warm to-day?)

"Where senioritas smoke and dance and drink Italian wine." (Burn my clothes.)

They journeyed to a little town, GARLICO was its name. (Hamburger.)

An old Italian stronghold which through smell had won its fame. (Lillies of the alley.)

And here they met Marconi, a duke of great renown. (Very episeitic.)

Who told them that he knew where a Kanoofis could be found. (Smart teller.)

He said there was an island in the ocean far away. (And she wore a yellow ribbon.)

The name of it and where it was, he did not care to say. (Oh, do tell.)

But he told us when the wind blew West, and the ether waves rolled high. (Heave to, me lads.)

To look for it with all our might, and we'd find it hye and hye. (Mama go bye-bye, too?)

We told him that he was a prince, although he claimed not such. (Not he.)

And mentioned he had helped us out in general, much too much. (Big hearted.)

Then we left GARLICO, bound for Egypt, valley of the kings. (Tut, tut.)

Now get the next installment and we'll tell you startling things. (Gee, I'm gonna get it, too.) —ROZEE.

(Cheer up, only two more parts.)

Mike Rofarad Sez It's a Tight Squeeze

Dear Mr. Gest: I have frequently heard mention of real, dyed-in-the-wool Radioknuts, and some of them are interesting specimens, but have you heard anything to beat this? I have a girl friend who is such a confirmed Radioknut that she refers to her Gossard as her "Variable condenser"! Yours disrespectfully, ELLIS BROAKLEWSE

A-B-C Lessons for Indigest Beginners

Chapter I—The Antenna Does Which?

BY GOSH

A IS for antenna
Put up to bring in sound,
Sometimes it brings in lightning.
Through your set, down to the ground.

Indigest Plant Mustava Call!

The Walla Walla government has the whole alphabet to choose station calls from as no stations have been assigned calls there up to date. When Indigest established its station on this tropical isle the head gazunkus of the political ring said, "Indi, my most valuable counsel, you can choose any call you please for your station."—Now we put it up to you! Indigest is going to call on its readers to contribute a name for our plant. Send in your suggestions at once and we are going to pick the best one and award one genuine brass, beveled edge, round switch point to the one who sends in the winner. The picture of this marvelous and magnanimously inspired prize will appear next week. Watch for it!

Asleep here is Tom McAlaster Geyre. He put up an antenna And tried to walk wire.

Looking Ahead

In Next Week's Issue of Indigest Anticipate Nothing

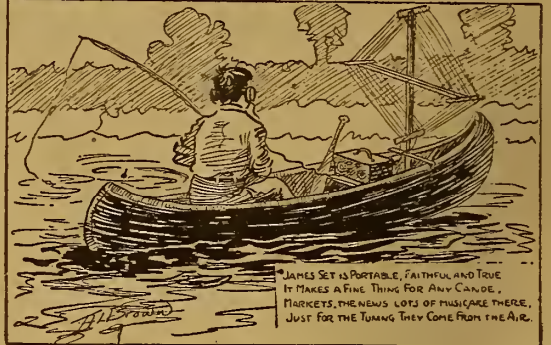
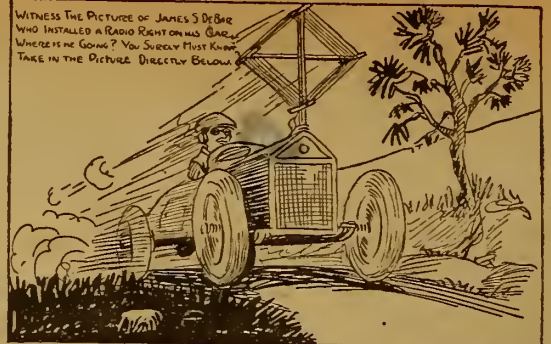

JAMES SET IS PORTABLE, FAITHFUL AND TRUE IT MAKES A FINE THING FOR ANY CANOE. FISHERS, THE NEWS LOTS OF FISH CAKE THERE, JUST FOR THE TUNING THEY COME FROM THE AIR.

Condensed

By DIELECTRIC

The owners of Station CFCN have launched into the business of manufacturing broadcasting sets and have already sold sets for use in Canada, Mexico and South America. Their programs are heard at considerable distances from Calgary and the W. W. Grant Radio, Ltd., is pretty well known in all parts of this country. Soon these Radiophone broadcasters will be talking back to the maker in Spanish.

When President Harding starts out on his trip across country he will have at hand a very powerful set installed in his private car. This is the first time that a broadcasting set of such power has been used on a railway train. It will also mark an epoch in the speechmaking of a head of this nation. Never before has it been possible for the rest of us to hear presidential addresses when hundreds of miles away, but now we may follow him as he speeds across the land stopping to speak at various towns enroute. Radio does it!

Radio control of the movements of ships has been tried with success on more than one occasion; a notable instance of this was the sinking of the Battleship Iowa off Panama Bay. There was no one on board as the ship was directed to the right or left in giving practice to the American gunners in hitting vessels under steam. More recently the French have tested the use of Radio in directing an airplane under similar conditions—pilotless. From the take-off to landing each move of the plane was actuated by Radio-control devices. It may be found practicable to substitute this medium in many lines now dependent solely on the presence of men.

Mississippi has resisted the impulse to join her sister states in the modern method of addressing the world until now. The first station to be licensed is the University of Mississippi, which has decided on programs of college songs and orchestra music. No doubt the alumni of this institution will be pleased to hear from their alma mater, but I am expecting to learn of educational features in the fall that will appeal to hundreds besides.

Not long ago Station WOR had rather a unique feature on its program when Bebe Daniels was interviewed by David A. Balch, editor of Movie Weekly. Miss Daniels was warned that not only Radiophans all over this country would hear her replies to his questions, but that the young lady with pad and pencil in the studio would take down every word to be given later to the readers of his paper. Judging from her answers she had prepared herself for the ordeal and made some pretty good "shots" in reply.

We are coming more and more to realize how very necessary Radio is to obtain a large hearing on any subject at any one time. In a case of distress, such as that recently in Colorado, Texas, an appeal may be made to folks in every state in the Union from a broadcasting station and quickly benefit thereby. A cyclone having struck this Texas town leaving much suffering in its wake, WBAP was asked to broadcast an appeal for funds. They poured in.

Preaching in churches with empty pulpits is becoming a thing of usual occurrence. Folks sit in their regular pews, sing, join in prayer and listen to sermons with no preacher anywhere in sight. When a church in Birmingham, Ala., found themselves without a preacher for the evening service they just made use of the pastor of another church in the city whose message was being broadcast. Another small church in New Jersey used a loudspeaker to fill their pulpit at short notice and it did well for the entire service of a church in New York city was brought to the congregation.

First Steps for Beginners in Radio

Chapter VI—About Crystal Detectors

By Thomas W. Benson, A. M. I. R. E.

FOR several years in the earlier stages of Radio and before the development of broadcasting stations most Radio reception was accomplished with crystal detectors. Although they are scoffed at today for long range work very remarkable records were hung up in other days. Perhaps this was due to the fact that one had to use a crystal and for that reason coaxed the most out of it. Even today it stands superior to the tube for clearness and freedom from noise as one can testify after listening to a reflex set using a crystal detector.

Crystal Detector Action

Just how the crystal detector functions is still a matter for debate but the prevailing theory is that of rectification. The currents induced in the receiving apparatus, are, as we have learned previously, of extremely high frequency. At 400 me-

BEGINNERS will find the accompanying series by Mr. Benson very helpful in learning the rudiments of the popular science of Radiophony. The articles yet to appear are:

- Chapter VII—Tube Detector Theory and Operation.
- Chapter VIII—The Regenerative Detector.
- Chapter IX—Radio Frequency Amplification.
- Chapter X—Audio Frequency Amplification.
- Chapter XI—How Super Regeneration Is Accomplished.
- Chapter XII—Reflex Circuit Operation.
- Chapter XIII—About Headsets and Loud Speakers.
- Chapter XIV—Batteries Used in Radiophony.

fect of this current is to charge the condenser connected across the phones and the potential of the condenser will vary as the amplitude of the current waves.

color and fractures very unevenly when split.

For Radio work a good piece of galena is superior to iron pyrites but a good piece is rare and to be treasured. Galena is very sensitive to heat and its detecting properties are oftentimes completely destroyed by the heating incurred during its mounting in metal. For that reason the crystal should be obtained loose and held in the cup with a set screw in preference to being set in molten metal.

Holder for Crystal

The type of stand used with galena should be fitted with a fine cat whisker so the contact will be light. And therein lies the disadvantage of this crystal, for to obtain great sensitiveness an extremely light contact is necessary. This is easily jarred out by slight vibrations. A short silver wire makes a very good cat whisker. A form of detector stand easy to construct and particularly suited to galena is shown in Figure 28. It can be made easily by anyone, the standard being a double binding post with a short brass rod through the top hole having a knob

into place with tinfoil. A brass plate on the base makes contact to the crystal holder and permits the crystal being moved until the most sensitive spot is found.

Experiments have been tried using various substances other than metal wires for contacts. Graphite is said to be superior to either silver or gold cat whiskers. The lead from a hard lead pencil sharpened at one end and attached with a small spring to the arms of the detector stand, shown in Figure 28, makes what is classed the best form of galena detector both as regards sensitiveness and freedom from burning out from static.

Iron Pyrites Detector

Let us now consider the iron pyrites. This crystal is shown preference by the Radiophans chiefly because it gives good results without much care in adjusting. It permits of more pressure being put on

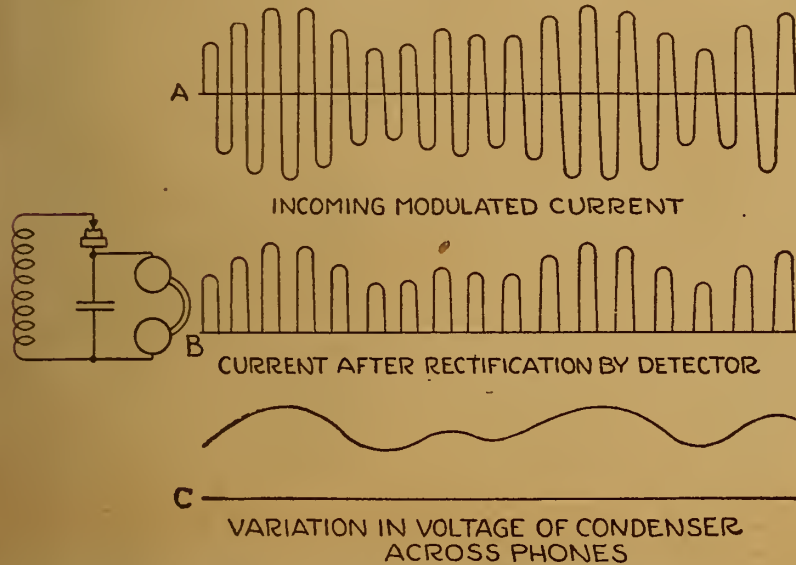

Figure 27—Showing Action of Detector in Radio Receiving Circuit

ters the current has a frequency of 750,000 cycles. If this current was made to act on the diaphragm of a telephone receiver it would vibrate back and forth that many times per second. The human ear, however, cannot respond to frequencies above 18,000 to 20,000 vibrations per second, so these high vibrations would not be heard.

Thus the voltage of the condenser is shown at C and the changes in voltage represented by the curve cause a movement of the telephone diaphragm in synchronism with the music or words striking the microphone at the sending station.

Materials for the Detector

Many substances have been used for detecting purposes with more or less success and each day sees the birth of some new substance or an old one in a new dress. The two most popular minerals that have been found the most sensitive are galena and iron pyrites. Galena is a natural sulphide of lead, its crystals being cubical in form, having a bright metallic lustre and can be readily split up into regular cubes. Iron pyrites is also a natural ore known sometimes as "Fool's Gold" from its yellowish sheen. It is of a bronze-yellow

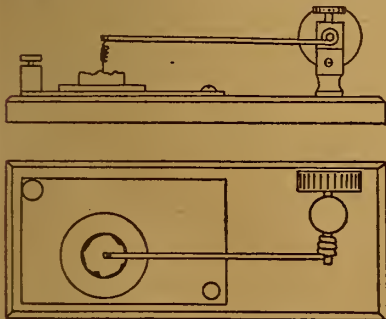

Figure 28—Details of Detector Stand Designed for Use with Galena

A crystal detector connected into the circuit acts to rectify the current, that is, allows the current to flow in only one direction and retards or prevents it from flowing the other half of the cycle.

This may be better understood from Figure 27. At A we have the current induced in the detector circuit showing the modulation of the waves by the microphone at the transmitter. At B is shown the same current after being rectified, that is, with the lower halves of the cycles cut off. The current is now direct but is pulsating, that is, flows in jerks. The ef-

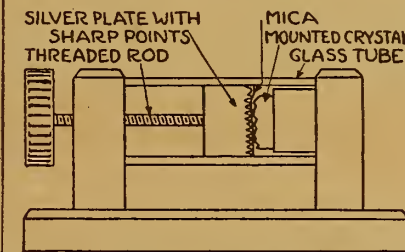

Figure 29—Details of Detector Stand to Obtain Permanent Adjustments with Iron Pyrites

fitted to one end and a stiff wire wrapped around the other end. A small spiral of about No. 30 silver wire soldered to the stiff wire serves as a contact for the crystal. The crystal itself is mounted in a rather thick brass washer and wedged

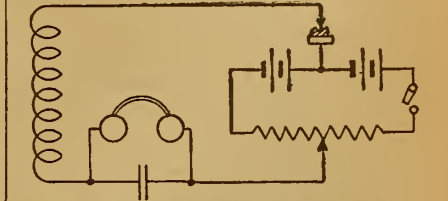

Figure 30—Circuit Employing Potentiometer and Local Battery to Pass Current through Crystal Detector

the cat whisker and hence is not so liable to be jarred out of adjustment. Not being so sensitive to heat it can be mounted in metal without difficulty.

It is not necessary that the stand used with iron pyrites have very delicate contact so any stand on the market can be used with success. However, the form of detector stand, shown in Figure 29, possesses several features to make it worthy of construction by those desiring the most from their crystal sets. With some changes several of the detector stands on the market can be adapted to this principle. It consists simply of a glass or other insulating tube mounted between two brass standards. A crystal of iron pyrites is put in one end as shown and a thin sheet of mica placed over the crystal. The contact member is made from silver. A dime may be soldered to a thick brass disk for the purpose and its face cut into fine ridges with a sharp, three-cornered file, making cuts at right angles. The face of the dime is then covered with many fine points.

Makes Near Perfect Fixed Detector

The contact plate is slipped in against the mica and a screw threaded into the other brass post used to force it against the crystal. With the detector connected

(Continued on page 14)

Electric Soldering Iron

\$2.50

A. C. OR D. C. CURRENT

DEALERS—Attractive Discounts

HUDSON-ROSS

123 W. Madison St. Chicago

Delicate Soldering

THE POST SOLDERING IRON

Platinum Heating Unit—Interchangeable Tips—Universal Current

(Large and Small)

\$6 ONE-HALF ACTUAL SIZE

Awarded Certificate of Excellency, N. Y. Evening Mail Radio Institute

From your Dealer, or write

POST ELECTRIC COMPANY (Dept. 509), 30 E. 42nd St., New York

WILLARD RADIO COMPANY

291 Broadway "The Best for Less" New York City

FLEWELLING CIRCUIT Every part complete, including drilled panel and book of diagrams and instructions \$11.95	REINARTZ CIRCUIT Every part complete, including drilled panel and book of diagrams and instructions \$10.95
Two-stage Audio-Frequency Amplifier. Every part complete for above circuits at \$11.00	

A Recommendation

Hartford, Conn., June 4th, 1923.

Willard Radio Co.
New York City.
Dear Sirs:—

I received the Flewelling Circuit complete and wish to thank you. It is a beauty. I set it up in one hour and a half, but I have to get batteries so I wish to thank you again, also for the present that you sent me.

I have priced the machines here in Hartford and find that they cost anywhere from \$35 to \$190. I do not see how you can sell them so cheap.

I will close now but if I want anything in the future, you will have my order.

Again I wish to thank you.

I remain
Yours truly,
CHAS. W. HIGLEY.

147 Babcock St.,
Hartford, Conn.

CONDENSERS	
3 Plate Variable; value, 1.75.....	\$1.05
13 Plate Variable; value, 2.50.....	1.20
23 Plate Variable; value, 3.50.....	1.35
43 Plate Variable; value, 4.50.....	1.95
13 Plate Vernier; value, 5.50.....	3.75
23 Plate Vernier; value, 6.00.....	4.00
43 Plate Vernier; value, 6.50.....	4.25

Honeycomb Coils, 50 turns mounted.....	.95
Honeycomb Coils, 75 turns mounted.....	1.00
Double Coil Mountings.....	2.45
Triple Coil Mountings.....	3.35
Reinartz Coil increased wavelength, and mounting.....	1.75
Jacks, Single Circuit; value, 65c, special at... ..	.30
Double Circuit; value, 90c; special at.....	.45
Multiple Point Inductance Switch with Knob and Dial (15 Switch Points).....	1.45
Lightning Arresters, approved.....	.90
Three-inch Dials, unbreakable, heat resisting composition, high finish; special.....	.30
Two-inch Dials, same design, for rheostats and potentiometers; special at.....	.25
Aluminum Loud Speaking Horn, nickel plated, highly polished; \$8.00 list.....	3.75
Filament Rheostat, 6 ohm.....	.65
Filament Rheostat, 20 ohm.....	.80
Filament Rheostat, 50 ohm.....	.90
With 2" Dial, 15c extra.	

A beautiful "SALRITE" pencil FREE with every order of \$12.50 or more. Made of beautiful Wabogantite Rubber—five inches long. Equipped with vest-pocket clip, 10 leads and eraser.

Now is the time to build your own set to take with you on your vacation. We will be glad to offer you any information or advice that you may require. Just drop us a line.

Every article advertised above is guaranteed by the manufacturer and by us. Mail orders filled immediately. Transportation PREPAID on all orders of \$5.00 or over, east of the Mississippi River. All others include postage.

Flewelling Circuit in Portable Set

Makes Ideal Apparatus to Use on Camping Trip

As will be seen by the halftones the entire portable Flewelling outfit is assembled in a cigar box which measures 9 inches long, 6½ inches wide and 2½

WORKSHOP KINKS? EARN A DOLLAR—

THERE are many little kinks worked out at home that would aid your fellow Radio worker if he only knew about them. There are new hook-ups, new ways of making parts and various unique ways of operating sets that are discovered every day. Radio Digest is very much interested in securing such material. Send them in with full details, including stamped envelope so rejected copy may be returned. The work must be entirely original, not copied.

RADIO KINKS DEPARTMENT,
Radio Digest
123 West Madison St., Chicago, Ill.

inches deep. This box was finished with a good coat of insulating varnish inside and outside. The varnish used was made by dissolving ordinary phonograph records in alcohol.

The coils are one 50 and one 75-turn, but I believe a 45-turn coil for the tuning inductance would be better, as the 360-meter stations don't come in very well

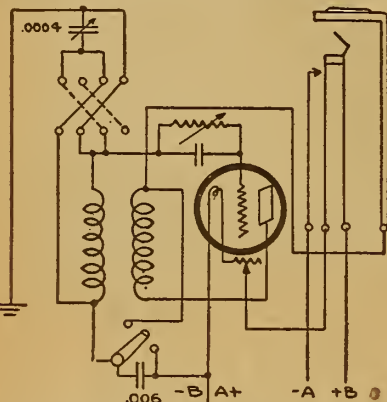

with the 50-turn coil. The condenser has .0004 mfd. capacity. The tube used was a VT-2. The set also is equipped with a variable leak and grid condenser. In the upper right corner is the automatic filament jack while a current adjuster controls the current flow to the filament.

I obtain the best results using only one connection, that is either using the ground or one side of the 110-volt line on the

This is the New
DICTOGRAPH
RADIO
Loud Speaker
with The Adjustable Air Gap That Tunes Out All Harshness

Invite your friends tonight. Surprise them with a REAL concert or dance. The wonderful new Dictogrand will create the illusion that the artists are in the very room with you. Just go to your dealer's and hear this remarkable, clear-toned instrument. Take it home and plug in for the finest entertainment you've ever known. You don't need extra batteries.

Like all the other famous Dictograph Products, the Dictogrand is guaranteed for one year. If your dealer hasn't the DICTOGRAND in stock, write to us direct.

DICTOGRAND

Mahogany Finish

\$28.50



DICTOGRAPH PRODUCTS CORPORATION
220 W. 42nd St., N.Y.C.

CIGAR BOX HOLDS FLIVVER SUPER

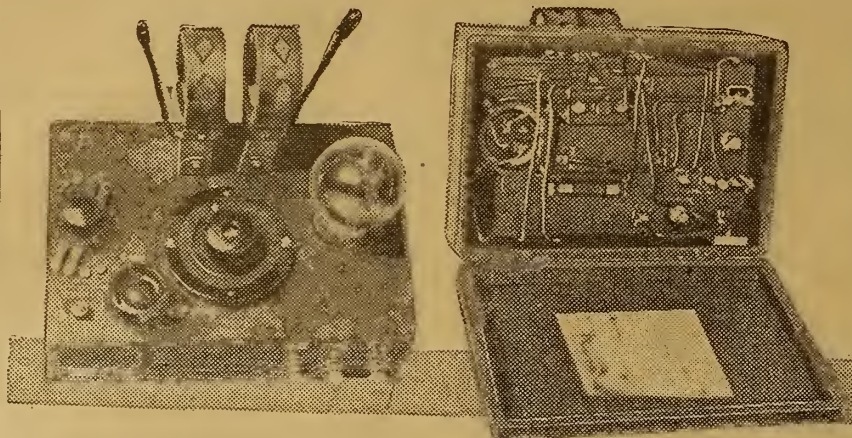

aerial binding post. Equal results were obtained by using a telephone ground.

The first time I tried the set I was dumfounded by hearing KFI Los Angeles, and with only the ground connection. It seemed incredible. I could hardly believe my ears, WMC, WEAF, WLAG, KSD, WOC, WOAW and several others also come in so loud as to be audible several feet from the phones. It truly is a wonder-box and it is nothing short of miraculous the way they come in.—Francis W. Lovgren, Virginia, Minn.

"A" Battery Condition

A storage battery of the lead-acid type when fully charged and on open circuit should have a potential of 2.2 volts per cell and a specific gravity of 1.260 to 1.280. When placed in service and used under normal operating conditions a fully charged battery has a potential of 2.0 volts per cell and a specific gravity of 1.225. When the potential of the battery has fallen to 1.8 volts per cell with a specific gravity of approximately 1.175 it should be placed on charge. When a battery is connected to the charging source, the positive terminal of the battery must be connected to the positive lead of the charging power supply.

Grid Leak Resistance

In vacuum tube receiving sets employing grid condenser and leak, it is found in some cases that broadcast signals are received clearly when the set is placed in operation, but suddenly cease after a short interval. Disconnecting the plate

battery and then reconnecting it causes the signals to be resumed for another period and then cease abruptly as before. This condition results from the use of a grid leak having too high a resistance, thus allowing the accumulated charges to choke the tube. Disconnecting the plate battery for a time permits the charge to leak off and allows the set to function for a short interval until the charge builds up and again chokes the tube. The remedy is to draw a few pencil lines across the grid condenser. These lines should make good electrical contact at each end with the terminal posts of the condenser, thus reducing the resistance of the grid leak.

HOOK-UP BLUE PRINTS WITH ALL PARTS' VALUES GIVEN FOR—

- 1—Hazeltine Neutrodyne
 - 2—Gibbons Ultra Audion
 - 3—Cockaday Four-Circuit
 - 4—Single Tube Reflex
 - 5—Three Tube Reflex
 - 6—Flewelling Flivver
 - 7—Armstrong Super Regenerative
 - 8—Armstrong Super Heterodyne
 - 9—New Ultra Reinartz
 - 10—Kaufman Circuit
- These helpful prints designed by a Member of the Institute of Radio Engineers. All ten mailed prepaid for five dollars (\$5) or single prints at 75c apiece. Send money order or check (no stamps).

HOME WORKSHOP CO., P.O. Box 1062, Chicago

Double Filament Globe Makes Battery Charger

Electrolytic rectifiers are usually used where small direct currents are required, such as for charging B batteries. However, this type of rectifier is troublesome and dirty and therefore not very desirable. A far more efficient instrument is shown in the illustration. It consists of a double filament automobile headlight bulb used for the rectifying unit and a step down transformer having the proper secondary voltage to light one filament of the globe. The other filament is not lighted, but used in place of the plate common to bulbs made for this purpose.

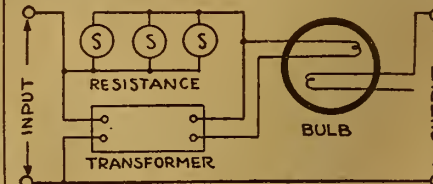

A variable resistance consisting of a water rheostat or a lamp bank is placed in series with the bulb to bring the voltage down to the required pressure. When large currents are required it is advisable to connect three or four of these bulbs in parallel.—D. Y. Solandt, Toronto, Ont.

SOMETHING NEW

A real Loud Talking Detector made of "B" Metal. 100% superior to any crystal. Puts new life into your set. Guaranteed for one year. It's the cheapest in the long run.



50c

Sold by all live dealers, or can be ordered from the
B-Metal Refining Co.
3134 Trumbull Ave.
Detroit, Mich.

THE LARGEST RADIO STORE IN AMERICA

BUILD YOUR OWN SET

THE LARGEST RADIO STORE IN AMERICA

ACCORDING TO OUR INSTRUCTIONS
RESULTS GUARANTEED—PANELS ON ALL SETS DRILLED—
READY TO MOUNT

<p>Complete Parts for Knocked-Down Receiving Set \$17.95</p> <p>CONSISTING OF</p> <ul style="list-style-type: none"> 2 Variometers \$10.00 \$3.90 1 Variocoupler 5.00 1.75 3 Bakelite Dials 3.00 .75 Remler Bakelite Socket. 1.00 .45 Howard Rheostat 1.10 .80 Cunningham C-300 Detector Tube 5.00 4.45 Mahogany Cabinet 4.50 2.75 Genuine Formica Panel 2.25 1.75 8 Binding Posts80 .40 Switch Lever50 .25 12 Switch Points40 .20 Freshman Grid Leak and Condenser Combined.. 1.00 .75 Complete Drawing for Assembly and Wiring 1.00 .50 <p>Regular Price \$30.85 Our Price \$17.95</p>	<p>Complete Parts for Reinartz Sets \$11.45</p> <p>CONSISTING OF</p> <ul style="list-style-type: none"> 7x18 Formica Panel..... \$1.89 \$1.70 Remler Bakelite Socket. 1.00 .45 Howard Vernier Rheostat 1.50 1.35 23 Plate Variable Condenser 3.30 1.45 11 Plate Cuni Variable. 3.10 1.35 3 Switch Levers 1.50 .75 2 Dozen Switch Points. .80 .40 1 Schoonhoven Reinartz Coil 3.00 1.95 Freshman Variable Grid Leak and Condenser Combined 1.00 .75 8 Binding Posts80 .40 25 Feet Tinned Wire. .30 .20 Baseboard for Mounting .50 .25 Blueprint with Complete Instructions for Assembly and Wiring 1.00 .50 <p>Regular Price \$21.69 Our Price \$11.45</p>	<p>Complete Parts for 2 Step Amplifier \$12.45</p> <p>Can be used to amplify Reinartz, Flewelling, Short Wave Receiver, Crystal, Ultra Audion or any Receiving Set so that Loud Speaker or Phonograph can be used in place of Head Set.</p> <p>CONSISTING OF</p> <ul style="list-style-type: none"> 7x10 Formica Panel or Other Suitable Size. \$1.05 \$0.85 High Ratio All-American or Thordarson Transformer 4.75 3.95 Low Ratio Thordarson or All-American Transformer 4.50 2.95 2 Howard Rheostats..... 2.20 2.00 2 Remler Bakelite Sockets 2.00 .90 3 Double Pencil Jacks. 3.00 1.50 13 Binding Posts..... 1.30 .65 Baseboard for Mounting .30 .15 <p>Regular Price \$20.10 Wiring Diagram, with Complete Instruction for Drilling and Assembling Panel \$2.45 Our Price \$12.45</p>
<p>Complete Parts for Flewelling Circuit \$12.45</p> <p>CONSISTING OF</p> <ul style="list-style-type: none"> 6x14 Formica Panel... \$1.26 \$1.10 23 Plate Variable Condenser 3.30 1.45 Three .006 Mica Condensers 3.00 2.25 CRL Variable Grid Leak 1.85 1.35 Remler Grid Leak..... .40 .25 2 Coil Adjustable Honeycomb Coil Mounting with Knobs 4.00 2.65 50 Turn Honeycomb Coil .75 .40 75 Turn Honeycomb Coil .80 .40 2 Remler Coil Mounts with Straps 1.20 .80 1 Remler Bakelite Socket 1.00 .45 Howard Vernier Rheostat 1.50 1.35 1 Bakelite 3" Dial..... 1.00 .25 6 Binding Posts..... .80 .40 1 Baseboard for Mounting30 .20 1 Blueprint with Complete Instructions for Assembly and Wiring. 1.00 .50 <p>Regular Price \$22.16 Our Price \$12.45</p>	<p>Complete Parts for Ultra Audion Circuit, \$11.90 (Known as the Wonder Circuit)</p> <p>CONSISTING OF</p> <ul style="list-style-type: none"> 9x10½ Formica Panel. \$1.42 \$1.20 23 Plate Condenser 3.30 1.45 Bakelite Socket (Remler) 1.00 .45 Special Ultra Audion Coil, plain or bank wound with tape 3.00 1.95 Howard Vernier Rheostat 1.50 1.35 CRL Grid Leak..... 1.50 .95 .0005 Micon Condenser. .35 .25 2 Switch Levers..... .70 .50 18 Switch Points50 .30 2 Switch Stops10 .05 8 Binding Posts80 .40 Genuine Solid Mahogany Cabinet, size 9x10½, with hinged top. 5.00 2.95 25 ft. Hookup Wire..... .20 .10 <p>Regular Price \$19.37 Each order includes complete instructions for drilling, assembling and wiring. These construction plans are not drawn in schematic form but are drawn so that any one without any technical knowledge can follow with ease. \$11.90 Our Price \$11.90</p>	<p>Complete Parts for Single Tube Reflex Circuit \$32.65</p> <p>CONSISTING OF</p> <ul style="list-style-type: none"> 43 Plate Vernier Variable Condenser \$7.00 \$3.95 Radion Loop Aerial... 8.50 5.95 Cunningham C301-A Tube 9.00 5.95 Grewol Glass Enclosed Detector 2.00 1.65 Erla Radio Frequency Transformer 4.50 3.45 All-American 5 to 1 Radio Audio Frequency Transformer... 4.75 3.95 2-.001 Micon Condensers .70 .50 1-.002 Micon Condenser .45 .35 Howard Potentiometer.. 1.50 1.35 Howard 25 Ohm Rheostat 1.10 1.00 8 Binding Posts80 .40 9x10½ Formica Panel.. 1.42 1.20 9x10½ Genuine Solid Mahogany Cabinet with Hinged Top..... 5.00 2.95 <p>Complete instructions for drilling, assembling and wiring furnished so that any one with no technical knowledge can easily follow. Regular price, \$45.22. Our Price \$32.65</p>

We guarantee all merchandise purchased of us. Mail orders receive immediate attention.

BUY HERE FOR LESS

CHICAGO SALVAGE STOCK STORE
509 South State Street Dept. R. D. CHICAGO, ILLINOIS

Book of HOOK-UPS
For One Dollar
Reinartz Flewelling Reflex

many others, simple and elaborate, fully diagrammed and explained. Used continuously by thousands of Radio fans, both amateurs and professionals. The greatest book ever published for experimenting. Keep this valuable little book before you at all times. Send your check or money-order for one dollar and the book will be mailed to you. Forty-seven hook-ups, all different. Send your order today. The edition is limited.

Book of Hook-ups, \$1.00

E L S RADIO COMPANY
Randolph Building
CHICAGO, ILL.
Special Offer to Dealers

How to Make a Camper's Portable Reflex Set

Part I—Carrying Case and Built-in Loop

By H. J. Marx

ONCE a Radlophan—always one! Yet there are times when using the Radio set may present some difficulties. Probably the biggest vacation problem is to keep down the necessary luggage to be taken along. Few of us are experienced enough travelers to be able to keep the necessities to a minimum.

Taking all this into consideration, the dyed-in-the-wool Radlophan stops to think twice when he considers taking his Radio set with him on his vacation.

First and foremost—he surely can't cart around a storage battery. But, the advent of dry cell tubes has solved that difficulty.

Aerial Problem

Second, the question of aerials has been a big drawback. There are two ways of solving this problem. One is to use a wire aerial that can be temporarily rigged, and

wood and covered on the outside with fiber. It has the usual assembly of brass corners, straps, clips and locks. The cover has a wooden frame with fiber over it.

Cases of exactly the same size and make may be difficult to obtain. If an approximately similar size is available, the layout of the apparatus can be altered to suit. Undoubtedly a number of fans will want to construct the cabinet or case themselves. In that event the use of finished quartered oak $\frac{3}{8}$ inch thick is suggested. The brass corners and straps can be purchased at 5 and 10 cent stores.

The inside dimensions of the body of the case were $17 \times 12\frac{1}{8} \times 5\frac{1}{2}$ inches deep. The body is divided into two sections, one for the set itself and one for the batteries and head receivers.

Need Two Panels

Two panels are required, one measuring

After apparatus space has been accounted for, an ample space $12\frac{1}{8} \times 9 \times 5\frac{1}{2}$ inches is left for the batteries and head receivers.

Loop Aerial in Top

The cover of the case has been utilized for the loop aerial. As shown in the il-

The cover is 1 inch deep so that ample room is provided for clearance of the dials and the loop. If properly located the binding posts will not interfere with any of the dials.

The wire used for winding the loop should be No. 18 double silk covered. A

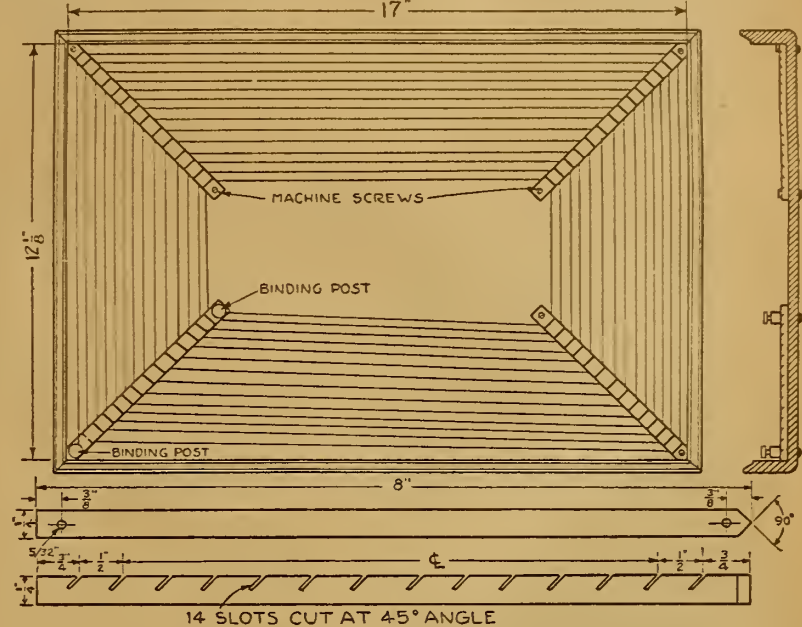
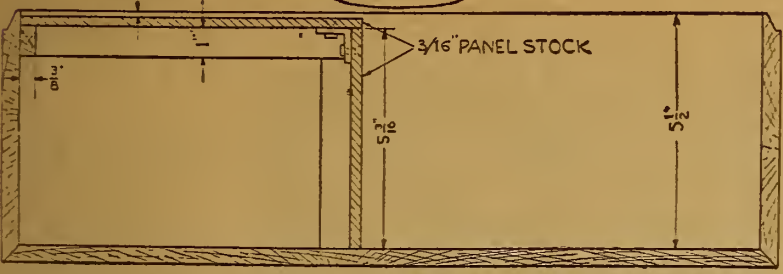
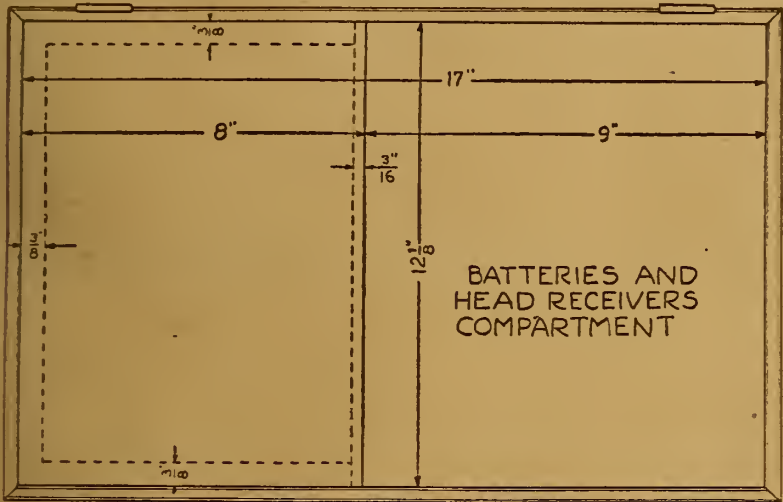

lustration, four strips of fiber or panel stock $\frac{1}{4} \times \frac{1}{4} \times 8$ inches long are slotted to carry the wire. These are fastened at an angle of 45° in the four corners of the cover by means of machine screws and nuts. The one in the lower left side next to the apparatus compartment is fastened by means of the two machine screws running into the binding posts. The start and finish of the loop wire is in these two posts which are later connected to the set itself.

half pound spool will be all that is necessary for the loop.

The layout of the apparatus for the various circuits will be taken up later.

(TO BE CONTINUED)

Have a hook to put your telephones on after you have stopped listening in. If laid on the table they might land on the floor.

the other is to use a loop aerial with a type of circuit that will build up the strength of signals sufficiently. Loop aerials always offer the additional attraction that they are less susceptible to interference than the usual straight wire aerial. With loops the value of reflex circuits becomes more apparent.

If everything can be self-contained in a small traveling case—then the question of luggage space has been considerably simplified.

Choice of Three Hook-Ups

In the set to be described everything except the loud speaker is carried in a fiber sample case the inside dimensions of which are $17 \times 12\frac{1}{8} \times 5\frac{1}{2}$ inches. Three hook-ups will be placed at the option of reader. These are the two tube, three tube and four tube reflex circuits. These have all been tested and present another interesting little development in reflex design. The four tube circuit has already been assembled in the case to be described, so the fan need have no fears regarding the possibility of enclosing all the apparatus in the limited space available. If properly arranged there is a distinct advantage in compact layouts of reflex circuits; connecting lead lengths are reduced to a minimum.

Description of Fiber Case

The case itself is made up of $\frac{3}{8}$ -inch

$12\frac{1}{8} \times 8 \times \frac{3}{8}$ inch thick for the top, and one for the side $12\frac{1}{8} \times 5\frac{1}{2} \times \frac{3}{8}$ inches thick. Wooden strips $\frac{3}{8} \times 1$ inch are fastened on the inside of the body for supporting the panels. Both top and side panels are used for mounting the instrument. In addition two angles are used for fastening the two panels together. These, with the details for mounting the panel, will be described in detail later.



TULIP LOUD SPEAKER

The Horn Beautiful!

- 24" Complete \$18.00
- 20" Complete 16.50
- 24" Without Unit..... 12.00
- 20" Without Unit..... 10.50

Dealers Write for Discounts

CONRAD MARX

23 Judge St., Brooklyn, N.Y.

Western Distributor,

FORBES RADIO CO.

127 N. Dearborn St., Chicago, Ill.

The trick is in the Coil NO STORAGE BATTERY REQUIRED

No Radio Frequency Transformer used. Not Super but DOUBLE Reflex Regeneration. Works local without antenna or ground, and brings in the "FAR AWAY ONES" with more volume than you ever thought one tube could deliver. Money Order for 25 cts. brings easy to read diagrams and all information. Address:

JACK PRATT
508 Railway Exchange Bldg., Chicago, Ill.
P. S.: Its Radio Golf Record is 119,000 miles. First Trial Picked Up Havana from New York

The Mystery Circuit

WE REPAIR WD-11, \$3.50

and OTHER VACUUM TUBES

Excepting VT-I and VT-II

MAIL ORDERS Solicited and Promptly Attended To

H & H RADIO CO.
516 Clinton Avenue NEWARK, N. J.

Federal Standard Radio Head Sets

When you buy Federal Head Sets you obtain the lasting satisfaction that comes with Radio equipment universally endorsed by engineers and experts. Years of experience in making communication apparatus enabled Federal to enter the Radio field with Head Sets and other Radio apparatus unsurpassed for efficiency in operation. Permanent magnets, specially treated steel, and precision machining of metal parts are some of the outstanding features of construction that make Federal Standard Head Sets the best you can buy.

Ask your dealer for Federal Standard Head Sets. If out of stock he can get them from our nearest office.

Federal Telephone & Telegraph Company
Factory: BUFFALO, N. Y.
Western District Office: 417 South Dearborn St., Chicago, Ill.

SELECTIVITY IN PORTABLE R.D.-86

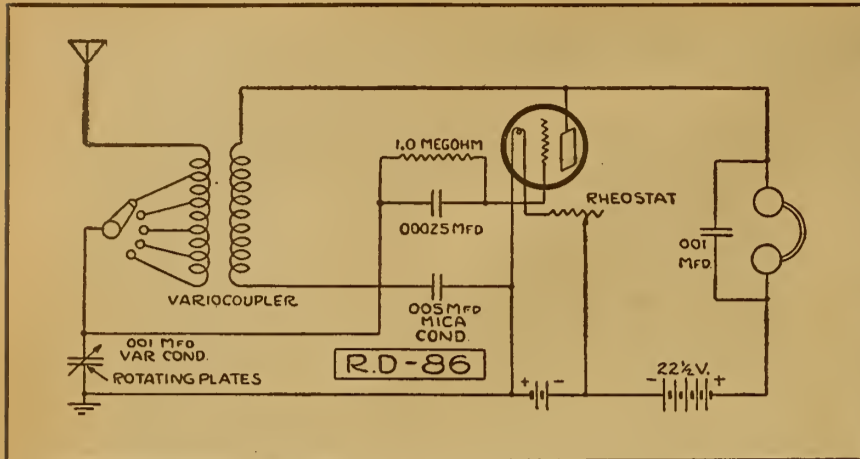

HERE is an unlimited field for good single tube portable set circuits. Any regenerative type of circuit will give good volume on a single tube. The main problem is to use a type of tuning unit that will permit maximum selectivity. In hook-up R.D.-86 a variocoupler is used in conjunction with a variable condenser for the tuning unit—the rotor supplies the feed back of the plate circuit.

The circuit is not primarily intended for loop aerial reception although one end can be connected to the antenna post, the other end left open, and a regular ground connection is used. When so connected, some very good results are possible. If a straight wire aerial is used, a length of 50 feet can be thrown over a convenient tree. Of course this will not give the best results. If time is available, the wire should be suspended between insulators.

A copper rod driven into moist ground will give sufficient ground connection. This can be improved by soaking the

ground around the rod with salt water. The tuning condenser should have a capacity of .001 microfarad, to cover the increased wave length range. The rotating plates should be connected to the ground side. A blocking condenser of .005 microfarad capacity is inserted in the rotor circuit so as to avoid short circuiting the batteries through the plate circuit. The grid leak can be of the variable type but this is left to the option of the maker. The tube is a detector, although hard tubes such as the C301A can be substituted. In such a case it may be advisable to increase the plate battery voltage. A cushion mounting for the tube socket is recommended as a portable set gets considerable knocking around that does not help preserve the tube filament. The rheostat resistance will depend on the type of tube used. If a UV199, C301A, or UV201A is used a 20 to 25-ohm rheostat is required. Otherwise the standard 6-ohm rheostat is sufficient.

FIRST STEPS IN RADIO

(Continued from page 11)

into the circuit the screw is run in slowly forcing the points on the silver plate through the mica and making contact with the iron pyrites. When the loudest signals are heard the detector is left adjusted and will continue to function indefinitely. This is as near perfect a fixed detector as it is possible to construct.

As with galena, iron pyrites used in a stand with a pointed piece of antimony fitted to the cat whisker for a contact, gives excellent results and is an arrangement recommended to users of the adjustable type of detector stand.

There are numerous other crystals advertised at present, the greater number of which are compounds of lead or silver and sulphur.

Synthetic Crystals; Clipping Contact.

One method of making these synthetic crystals is to bury two dimes in flowers of sulphur for a week or so. On removing one of the dimes it will be found covered with black silver sulphide and will function as a detector crystal. After using for a week the second dime can be brought into service and the first replaced in the sulphur for renewal. Thus the two are used alternately and will last indefinitely. This is worth trying.

When a metallic wire is used as a contact on the crystal it oxidizes rapidly and poor reception is often blamed on the

crystal when it is the fault of the cat whisker. The obvious cure is to clip the end of the cat whisker when the signal strength falls off so a clean, fresh surface of the metal is presented to the crystal.

An enclosed form of detector is advisable when the apparatus is subject to dust or moisture and not only reduces the oxidizing of the cat whisker, but protects the crystal as well.

Restoring Sensitiveness of Crystal.

Handling a crystal has been said to destroy its sensitiveness when as a matter of fact the sensitive points have been covered with a fine film of oil from the fingers and will not function in that condition.

BLUE PRINT DESIGNS

Build your own Receivers from accurate, dependable Designs. Carefully prepared drawings of that Portable Summer Set you want to take on your Vacation. Tells you how to make it and the kind of materials to use.

Designs for the Portable Ether Buster, Reflex, Reinartz, Flewelling, Neutrodyne, or any other will be sent you, postage prepaid, for One Dollar. Special Designs prepared.

THE RADIO CRAFTERS

Eighth Floor
20 East Jackson Boulevard, Chicago, Ill.

tion. The crystal can be restored to its original sensitive state by washing with pure alcohol or ammonia, scrubbing the surface with an old tooth brush. Allow the crystal to dry without wiping and the crystal will be found as good as ever. When completely insensitive, simply cleaving the surface of the crystal with a knife or cutting pliers will usually uncover more sensitive spots and make the crystal still of value.

Using Battery With Crystal

There is sometimes a slight advantage in using a battery in connection with a crystal detector and for the benefit of those who care to experiment with this arrangement a method of connecting the battery and potentiometer is shown so slight currents may be impressed on the detector by adjusting the potentiometer.

Two or four dry cells may be used with a 400-ohm potentiometer, opening the battery circuit while the set is not in use. The method of procedure is to first adjust the detector to maximum sensitiveness with the potentiometer at the center point and then by turning it one way or the other a slight current of the proper potential is applied to the detector.

Use of Condenser

Maximum signal strength can only be obtained when the condenser used across the phones is of a good grade. Use a mica condenser, or better still, one with air as the dielectric. Receivers will work without a condenser but it will be found the phone cords form a small condenser and thus permit reception.

There is still a wide field open for experimenting on crystal detectors or some similar rectifying device. A peculiar fact about any pair of contacts that will rectify high frequency currents, such as galena and silver, iron pyrites and brass, silicon and brass and so on through the list of crystals, is that one of the substances has photo-electric properties while the other has not. That is, one of them emits negative electrons under the influence of light, the other does not. Whether this has any bearing on the phenomena of rectification is still an open question, the solution of which may lead to some very important discoveries.

(TO BE CONTINUED)

The problem of tuning your set to best advantage will have to be worked out for yourself, as each set is a little different.

RADIO EQUIPMENT

EDISON Elements for making "B" Batteries, 6c per pair; tubes, 2c each. Nickel Wire, Insulators and Cabinets at reasonable prices. TODD ELECTRIC CO., 178 Lafayette St., New York City.

Reviews of Books

Radio Experimenter's Handbook. By M. B. Sleeper. This book will help in the selection and the construction of simple apparatus for transmission and reception of Radio telegraph and telephone signals. Price, \$1.00.

The Radio Amateur's Handbook. By A. Frederick Collins. A new revised edition of this book is just out. It is complete, authentic and informative work on Radio. Fully illustrated. Price, \$1.50.

Experimental Wireless Stations. By P. E. Edelman. Simple directions are given in this book for making Radio equipment for the transmission of messages over long distances. Price, \$3.

An Introduction to Radio. A real book for the amateur. This treatise comes in two volumes. 96 pages in each volume, fully illustrated with flexible leather covers. Price two volumes, \$1.

How to Retail Radio. A new book telling of tested plans and methods and policies for the dealer in Radio. Financing, location, store equipment and arrangement. Price, \$2.00.

Amateur Radio Call Book. Fourth edition just out. A complete list of amateurs, special amateurs, technical and training stations of the United States and Canada. How to construct and operate a Reinartz tuner, detector and one step amplifier. Large two color map included. Price \$1.00.

The book department of the Radio Digest is prepared to send you any of the books on Radio published, whether listed in our Book Review or not. Let us know what book you want, send us your check and we will see that the book is mailed to you. Postage stamps in payment for books not accepted. Send money order or check. Radio Book Department, Radio Digest, 123 W. Madison St., Chicago, Ill.

REFLEX

Erla Reflex Transformers

DEALERS: SEND FOR LITERATURE

HUDSON-ROSS
123 W. Madison St. Chicago

Coast to Coast on One Tube, and No Body Capacity

These popular hook ups use U. V. 199, W. D. 11 or W. D. 12 tubes. One hook up gives selectivity and 1500 miles with absolutely no body capacity, while the other gives the remarkable distance of coast to coast. Both prints post paid for 50 cents or any of the above tubes post paid \$5.75.

C. W. KAUTZ, Box 362 LANCASTER, PA.

Hytone Collapsible Aerial

Just Out! New and Original!

The most convenient aerial ever devised. Light weight. Portable.

Highly efficient for all forms of indoor and outdoor Radio reception. Works on all Tube Sets.

ADJUSTABLE TO LENGTHS FROM 5 TO 100 FEET

Can be installed or taken down in a jiffy, at home or at CAMP. Avoid complaints from the landlord. Eliminates the use of a lightning arrester. Does away with loops.

Saves Time, Worry and Money.

Price \$2.00. At Your Dealer's or Direct from

ELL ESS RADIO EXCHANGE, 57 Dey St., N. Y. City

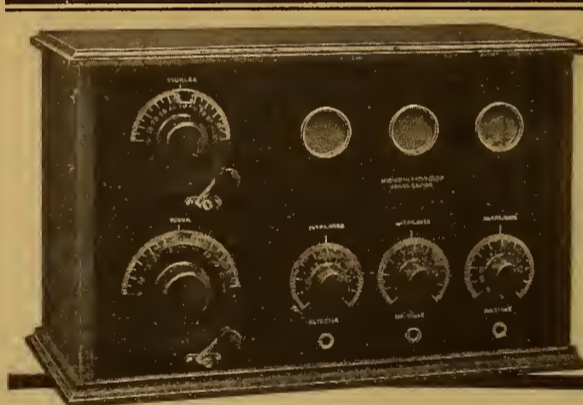

MICHIGAN "SENIOR" REGENERATIVE RECEIVER

A Large Measure of CERTAINTY and Much Less "Guessing"

Michigan "Senior" and "Junior" Regenerative Receiving Sets, with our patented Split-hair Vernier Dial Adjuster give the operator practically complete control of radio reception.

Our set owners report remarkable success in bringing in any desired station on which they had made previous dial-position records.

Troublesome nearby stations can be tuned out almost at will and signals come in clear, strong, pure-toned.

Loudspeaker reception on the "Senior," or on the "Junior" with our two-stage amplifier, is especially satisfactory.

Michigan Sets are Regenerative, licensed under Armstrong's U. S. Patent No. 1,113,149 and pending Letters Patent 807,388.

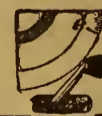

Michigan Accessories and Parts include vernier dial adjuster, two-stage amplifier, and a long line of highly perfected variometers, variocouplers, plate condensers, grid condensers, rheostats, etc. Send for our catalog.

MICHIGAN RADIO CORPORATION

GRAND RAPIDS, MICHIGAN

Questions and Answers

Radio Frequency Amplifier

(3900) HRH, Ft. Leavenworth, Kas.
I have been a reader of your paper for some time and have patiently waited for a Radio frequency hook-up to work on my tube CR No. 9, but so far I have not seen it. Hence this letter.

Could you send me a hook-up of 2 stages that would work on my set, preferably where it will not be necessary to change the set I now have, in fact, one

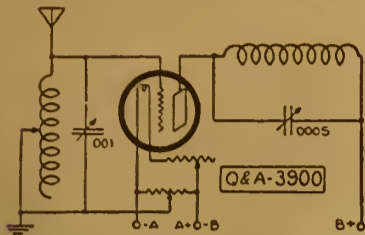

which would work like the one for the Flewelling you published May 12, 1923, page 13? Would like to have the diagram plainly marked as to capacity of different parts, etc.

A.—Complying with your request we are illustrating on this page a diagram showing method of adding one stage of Radio frequency amplification to Grebe CR No. 9. No changes in present circuit will be required. If desired additional stages of Radio frequency may be added in the usual cascade manner.

Output coil is placed in inductive relation to the tuner on the set. This output coil can be of the honeycomb type 25 to 75 turns, depending on the wave length desired.

Best Broadcast Receiver

(2863) ARL, Reading, Pa.
I wish to thank your Q. and A. department for previous questions answered. They may be interested in knowing that I have found the cause of my A.F. amplifier trouble to lie in the UV-201 tubes. It appears as though the plate current leaks through the tubes, the quantity depending on the degree to which the filaments are lighted. In one case, through the range of off to full brilliancy, the plate voltage dropped from 190 to 170.

What do you consider the best broadcast receiver from the standpoint of selectivity mainly but with as much volume as possible?

The two circuits you seem to be specializing on at present are the Reinartz and Flewelling, and I have read or heard that the Reinartz is not well adapted to phone. In answering this question, however, do not confine your consideration to those two only.

I presume the super-heterodyne is super-

ior but there is some doubt in my mind as to whether the large amount of apparatus and tubes required warrants their use. What is your opinion of a capacitively coupled tuner? I have recently finished calculations for one in which I figure I can obtain a 4-meter variation in the .0006-.0004 mfd. range of UC-1820 condenser, but have not started making same and have no idea what volume to expect.

Is it possible to use the Flewelling circuit for longer wave lengths and if so, what coils should be used?

A.—We are gratified to note that you have located difficulty which was disturbing the effectiveness of your circuit.

It is our opinion that the Armstrong three-circuit regenerative receiver is the most consistent and practical, aside from experimental interest. This circuit is hardly comparable with the super-heterodyne, which, however, is more intricate and difficult of operation by less than an expert.

Noting your reference to the Reinartz circuit, advise that it is as well adapted to phone as any other set.

We would not advise a capacitively coupled tuner as being selective.

The Flewelling circuit is not adapted for wave lengths over 800 meters.

Variocoupler Winding

(2608) RLT, Columbus, Ohio.
Would you kindly give me information on how to construct a variocoupler for the Flewelling circuit?

I have been following each and every one of his articles and note that he says for everyone to stick to the parts that he uses or the builder might be disappointed. He spoke of a variocoupler with 75 turns for a rotor and 50 for the stator.

As I travel for a construction company I would like to have this set portable, so I can carry it about with me, but with honeycomb coils the set is bulky to assemble for carrying.

Would like to have the size of tube and rotor, numbers of turns of wire, also size and kind of wire. I also ask you if the Variadon condenser manufactured by Du-Bilier Condenser and Radio Corp. is vernier enough in adjustments sufficient to use with this circuit instead of using the plate condenser?

A.—Answering your inquiry with reference to the variocoupler; use fifty-six turns of number twenty-two wire tapped every seventh turn for the primary and seventy-five turns of number thirty wire for the secondary. Wind on a standard size rotor and stator. Connect in Flewelling circuit in the same manner as the

honeycomb coils, primary as tuning inductances and secondary as tickler.

In our opinion, honeycomb coils would be much less bulky and will certainly be more efficient. Would advise adherence to specifications as nearly as possible.

The condenser suggested should serve effectively.

Ground Hum

(2888) JFT, St. Louis, Mo.

I made a socket aerial as per instructions in your magazine of February 24. I think it's just great, outside of one fault that I found with it, which is a loud buzzing sound that is so strong as to prevent me from hearing some of the local broadcasting. I have a crystal set and would appreciate very much if you will kindly inform me as to how I can overcome this annoyance?

A.—The annoyance of hum occasioned can often be overcome by grounding the minus side of the A battery in a tube set, but do not believe that there is any way of eliminating it with a crystal set.

Reinartz Circuit

(2474) JNS, Jacksonville, Fla.

Kindly advise me concerning the Reinartz circuit, on the following points: What covering should the wire have, S. C., D. C., silk, enamel or cotton and enamel?

It being difficult to obtain fibre board for winding the spider web coils on, what can be substituted instead?

What kind of insulating enamel gives the best results on these coils, or others?

A.—Use DCC wire. Cardboard, very thin wood, old phonograph records may be used for spiderweb coil winding.

We would not advise the use of enamel. Coils may be coated with a very thin shellac to guard against moisture.

WE REPAIR YOUR VACUUM TUBES
WD-11, WD-12, UV-199, UV-201-A.
C-301-A \$3.50 each
UV-200, C-300, AP Detectors..... 2.75 each
UV-201, C-301, AP Amplifiers..... 3.00 each
DV-6, DV-6-A 3.50 each
UV-202 4.00 each
And Guarantee Them Equal to New

QUICK SERVICE Include with your order remittance to cover repair plus parcel postage for one pound per tube. If preferred, tubes will be returned C.O.D. repair charges.

Abalene Radio 14 Vesey Street
New York, N.Y.

RADIO VIA PARCEL POST AT N. Y. PRICES
Standard Parts Only, in Original Packing
NO SALVAGED GOODS SOLD
Where "Money Back Policy Prevails"

PHONES For Parcel Post

Dietzen 3,000 Ohm.....	\$3.75	Ins. Add	\$0.12
Brown Single (4,000 Ohm Pr.).....	4.95		.09
Royal 2,200 Ohm.....	3.75		.12
Holtzer Cabot.....	7.95		.14

COUPLERS

Atwater Kent.....	6.80	.14
Freed Eiseeman (180 Degree).....	2.45	.09
All Wave (Genuine Capitol).....	6.95	.18

VARIOMETERS

Dayton.....	4.85	.12
-------------	------	-----

VARIABLE CONDENSERS

U. S. Tool 46-Plate Vernier.....	4.45	.24
U. S. Tool 24-Plate Vernier.....	4.10	.20
3 Plate Vernier.....	.95	.08
23 Plate Vernier.....	2.95	.14
43 Plate Vernier.....	3.45	.18

TRANSFORMERS (Audio Frequency)

Sampeon.....	4.95	.15
All American 3 to 1.....	4.00	.14
All American 5 to 1.....	4.10	.14
All American 10 to 1.....	4.30	.14
Acme.....	3.45	.14

TRANSFORMERS (Radio Frequency)

Acme.....	3.45	.14
Cotoco.....	2.95	.12
Owl.....	.95	.10
Sleeper.....	1.95	.10

MISCELLANEOUS

Hydrometers.....	.49	.08
Electric Soldering Iron.....	2.50	.15
Double Phonograph Attachment.....	1.15	.08

SETS

Westinghouse, Jr.....	6.95	.40
Aerex Crystal Set.....	7.95	.45
Victor Single Tube, completely assembled.....	12.50	.45
Victor Two Stage Amplifier.....	12.50	.45

RHEOSTATS

Klosner Vernier.....	1.25	.14
Bradleystat.....	1.49	.10
Union Radio.....	.65	.08

SOCKETS

Bell V. T. & W. D. 11.....	.89	.10
V. T. Bakelite.....	.50	.10

LUD SPEAKERS

King Amplitone Horn.....	4.95	.28
Pathe.....	17.50	.50
Reflex.....	9.85	.30
Phonaflex.....	15.00	.50

TUBES

Welch Peanut Tube.....	2.00	.10
Sterling 1 1/2 V.....	3.95	.15
Margo 1 1/2 V. (2 Element).....	1.00	.15
De Forest D. V. 6 A.....	6.00	.15

CABINETS (In White)

7x10.....	1.45	.20
7x12.....	1.65	.25
7x14.....	1.85	.30
7x18.....	2.15	.40
7x21.....	2.45	.45
7x24.....	2.95	.50

LIGHTNING ARRESTERS

Argue, Outdoor or Indoor.....	.95	.12
Brach, Outdoor.....	1.95	.14

DIALS

2-inch (Bakelite).....	.25	.06
3-inch (Bakelite).....	.35	.08

Modell's
ESTABLISHED 1899
191 Fulton St., Dept. F-18, New York City
9 New York Stores
America's Greatest Radio Mail Order House

THE B-T Reinartz-Vernier TUNING UNIT
Replaces tapped coils, eliminates soldering and gives greatly improved results.
Write for Circular and Diagram
BREMER-TULLY MFG. CO.
532 S. Canal St. Chicago

We Will Mail You One
"VERILOUD" SYNTHETIC RADIO CRYSTAL
COMPARE IT WITH WHAT YOU ARE NOW USING
OURS IS BETTER MAIL US 30 CENTS
IF NOT Return it at Our Expense.
ZOBEL-STEIN LABORATORIES
322 9TH ST. BROOKLYN, N.Y. SOUTH 2650

The Superlative Inductance
Four years of careful attention to the details of manufacture of this type of inductance unit has yielded a product of unquestioned superiority. And with increased efficiency in manufacturing methods, moderate prices prevail for all sizes
Ask Your Dealer
Cotoco
"Built First to Last"
COTO-COIL CO. PROVIDENCE

Calcutta on a Loop
(2579) GBV, Quincy, Ill.
A friend of mine states that twice last week he got Calcutta, India on a loop set, using three stages of Radio frequency and two stages of audio frequency, hearing voice and music.
The writer is not exactly familiar with what distances these signals may be picked up so I am not sure whether he is kidding me or kidding himself. I really believe an article in your excellent paper, of which the writer is a subscriber, covering this subject, including the possibilities with present day apparatus of hearing voice and music at great distances would be of interest, as there are a great many readers who would appreciate enlightenment on this subject.
A.—We are reluctant to dispute the word of your friend in stating that he has been in Radio communication with Calcutta, India, but a high regard for facts as they are bids us to assure you that he is spoofing you or kidding himself.
Radio communication beyond the range of the United States and Canada is not as yet achieved except under experimental tests under all favorable conditions of operation and equipment as recently accomplished in the Trans-Atlantic tests in which stations in England were received by a limited number of operators.

GOLD-GRAIN CRYSTAL DETECTORS
DEALERS—New List Attractive Discounts
HUDSON-ROSS
123 W. Madison St. Chicago

Your Choice
Radio Digest Illustrated
Illustrated
Illustrated
Illustrated
Illustrated

BOUND VOLUMES
Numbers
Two, Three or Four Postpaid by Parcel Post with One Year's Subscription to Radio Digest
Greatest Collection of Radio Information Ever Published
Reinartz Long Distance Circuit; Ultra-Reinartz Circuit; Flewelling "Filter" Circuit; Grimes "Inverse Duplex" Circuit; Single Tube Reflex Circuit; Armstrong "Super-Heterodyne" Circuit; Two, Three and Four Tube Reflex Circuits.
On account of the limited supply, the sale of these volumes is limited strictly to those readers who have subscribed for a year. One year subscription to Radio Digest and both bound volumes 2 and 3 or 3 and 4 or 4 and 2, \$7.00.
One year subscription to Radio Digest and bound volumes 2, 3 and 4, \$9.00.
ALL ORDERS MUST BE SENT DIRECT—No orders on this offer will be accepted through subscription agencies, news dealers or other sources. Check, money or express orders (no stamps) must accompany all orders.
Two, Three and Four Parcel Post Prepaid Each, only \$2.00.
13 Numbers in the Bound Volume—52 Numbers in Year's Subscription

65 Numbers
COUPON
PUBLISHER, RADIO DIGEST, 123 West Madison St., Chicago, Illinois.
Please reserve me Bound Volume Number Two and also Number Three, and one year's subscription to the Radio Digest, for which I am enclosing check—M. O. for Seven Dollars.
Please reserve me Bound Volume Number Two or Three or Four and one year's subscription to the Radio Digest, for which I am enclosing check—M. O. for Five Dollars.
Name.....
Address.....
City..... State.....

Radio Illustrated

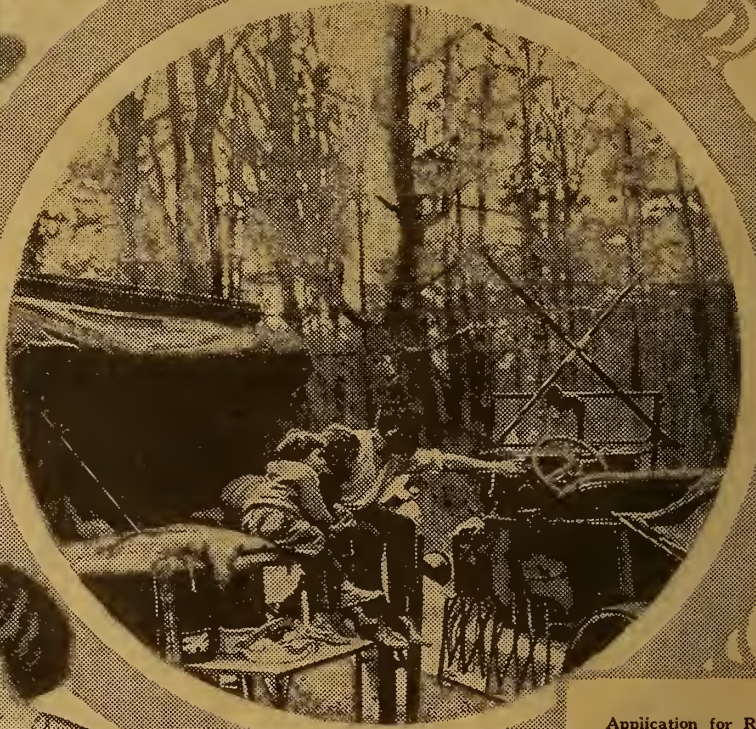

Application for Radio to the summer vacationists in supplying music and entertainment while in camp or on the road. It is just the thing to keep those - a w a y - from home in tune socially with the city world
© Travellette



Picking up a message at a stop on the road while en route to the camp. A portable set is a part of the camp equipment for the entertainment of the party. The antenna this party used was stretched from the car to a high tree and it effectively gathered in distant stations
© K. & H.

While in the woods Marie Stover, Maybelle Basett and Marguerite Ball of Chicago are entertained with a portable receiving set which they have taken along with them to the camp. You can never be so far away but what you can be at home for a few minutes with a good receiving set and loop aerial

At the right is shown a \$10,000 tourist sleeper sedan. Photo shows G. A. Beauchamp, owner, who, with his family, is making a two-year tour of the country. The big car is equipped with a long distance receiving set that it is believed will pick up many stations

