

60,000 CO

Vol. 1. No. 7
Co. E. C.

ALL S.

NEW CORPORATION FORMED OUT WEST

BALDWIN HEADS MILLION DOLLAR UTAH COMPANY

Proposed Holiday Factory Will Have Capacity of 3,000 Receivers Daily

SALT LAKE CITY.—A million dollar corporation has been organized and a factory site purchased at Holliday for the manufacture of the Baldwin Radio receiving sets on a large scale, according to an announcement made today by Holliday residents interested.

For several years Nathaniel Baldwin, genius and inventor, has manufactured, 3474 South Twenty-third East street, the Baldwin mica, diaphragm telephones which are declared by experts to be the nearest to perfection of any electro-magnetic Radio receivers in existence. With the development of the Radio-telephone and its sudden spread over the world, there developed a demand for these sensitive receivers which Mr. Baldwin has been absolutely unable to meet. Capacity of the new plant will be between 1,000 and 3,000 receivers a day from the beginning and the prediction is made that Salt Lake will shortly be in a position to supply the world demand for these instruments.

New Radio Station Started in Sweden

New Arrangement will Give Direct Communication Between United States and Sweden

NEW YORK.—Direct Radio communication between the United States and Sweden is said to be virtually assured through an agreement between the directors of the Swedish State Telegraph Board and the Radio Corporation of America. As a result the board has proposed to the Swedish government that the building of the large Radio station planned for the west coast of Sweden be immediately started. Radio messages between that country and the United States have hitherto mainly been transmitted and received via the station at Stavanger, Norway.

BROADCASTS CHEER DRY BANQUETERS

COLUMBIA, MO.—One of the big features of the thirteenth annual journalism week of the University of Missouri held here this week was a Radio banquet. The guests were limited to 350 persons because of seating capacity. Speeches, sketches from vaudeville acts and music were heard plainly by all the banqueters.

RA

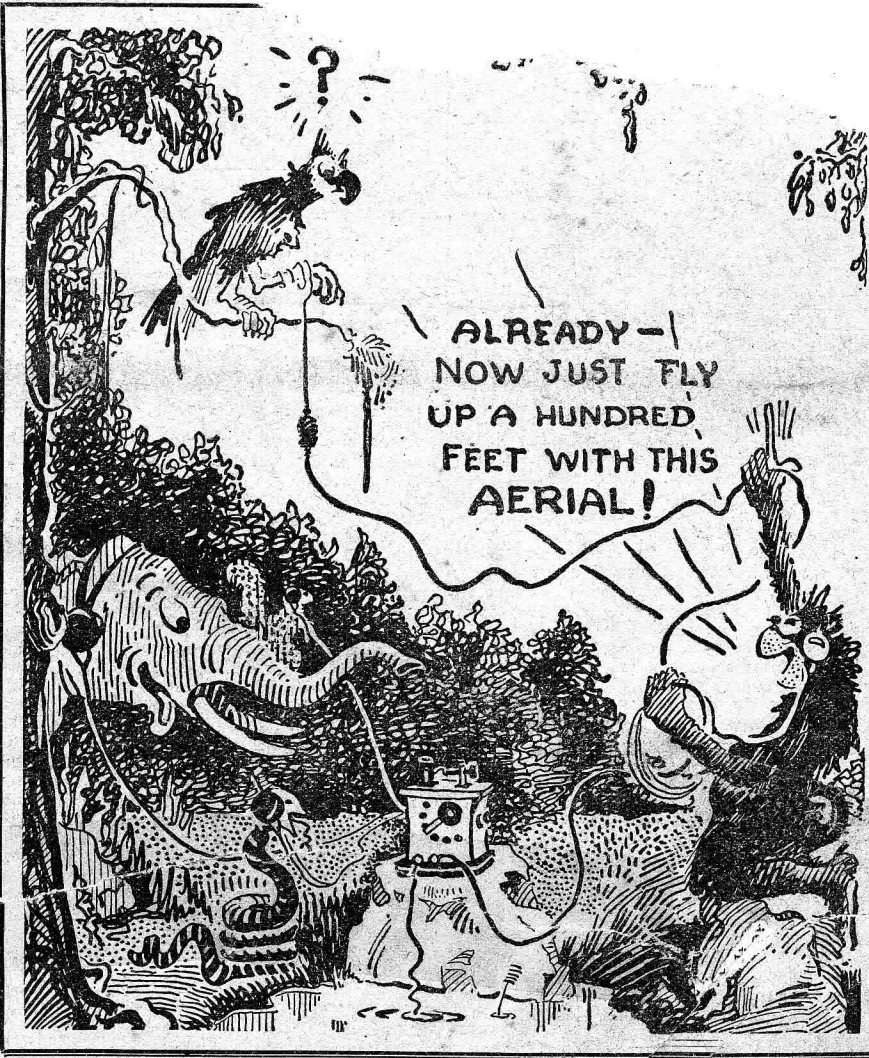

ALREADY—
NOW JUST FLY
UP A HUNDRED
FEET WITH THIS
AERIAL!

SCHENECTADY PLANT MAKES NEW RECORD

Concert of WGY Heard in Oakland, California

SCHENECTADY, N. Y. — The new General Electric Station has spanned the continent. This is the first time in history that the human voice was carried by Radio past the Rockies and beyond. The concert was broadcasted from Schenectady on a 360-meter wave length and acknowledged by wire three hours later from Oakland, Cal.

Pajprog Plans Radio Congress

CHICAGO.—A four-day congress on Radio is to be held during the Pageant of Progress as a part of its activities during August according to the program outlined at a meeting of the special committee.

2-Circuit Receiver To Be Shown In Bulletin

Bureau of Standards to Tell How to Make

WASHINGTON, D. C., May.—The Radio amateur may now construct a satisfactory 2-circuit receiving set with variable coupler, doing most of the work at home at but a slight expense, says the Bureau of Standards of the Department of Commerce. This set, which will be described in a government publication to be issued within the next few weeks, will have a much greater selectivity than the single-circuit set described and illustrated in Circular 120 of the Bureau of Standards. Most of the equipment which was used in connection with the single-circuit set can be used in the new outfit. The second publication, No. 121, will also be a Bureau of Standards Circular and will bear the title "Construction and Operation of a 2-Circuit Receiving Equipment with Crystal Detector."

Major J. O. Louis Cohen

Broadcasts A

Simple Instrument Kind of Set Means Revolution in Radio

The Airphone now has a "silent background." Static has at last been eliminated by the discovery of Major Joseph O. Mauborgne, signal officer of the 6th corps area of the United States Army, stationed in Chicago, and Dr. Louis Cohen, consulting engineer of the signal corps at Washington. Recent demonstrations before the representatives of the press in Chicago indicate beyond a shadow of a doubt that an apparatus has been found that will entirely eliminate interference in reception of Radio signals. This great discovery presages much for the future of Radio. It insures among many things the clear reception of all broadcasts during the summer time.

The new static eliminator is hooked-up with Major General George O. Squires, chief signal officer of the United States Army, inventor of line Radio—or so-called "wired wireless". A resonance wave coil is employed. The Radio current from the broadcasting stations traverses the resonance wave coil and from there goes to a receiving set of ordinary type, either vacuum or crystal, with or without amplifier, and only the signals affect the receiver. The static or interference is carried off into the ground. The result is that the reception is clear with no disturbing factors such as jarring, howling, or hissing.

The invention means to the fans throughout the country that Radio is a year-round proposition; that it will no longer be the victim of static that interferes so greatly in the summer time. Summer broadcasting is assured. On the initial tests, although the static was so terrific it would have been impossible to receive without the eliminating device, the broadcasts

(Continued on page 2)

NEW SONGS BOOSTED BY THE RADIOPHONE

BOSTON, MASS.—"At Eventide," a song composed by Frank H. Grey, whose past successes have won him an enviable position in the music world, was broadcasted recently on a Radio program by the well known baritone singer Charles A. Clary. This gave a good boost for the new song.

TS

Interference; Baldwin
ollar Corporation; New
n; Gives Radio Banquet 1
Reviewed by Dubilier;
ors Use Airphone; Antenna
omic, "Celestial Music"..... 3
ation of Receiving Set Given,
ation of De Forest Inter-Panel Re-
er Shown 4
o Receiving Sets (Fifth Photo Diagram
of Standard Outfit) 5
roadcasting Station Pictorial; WBT, WAAK
and NOF illustrated..... 6
"How to Make" Department; Vacuum Tube
Receptacle; Fixed Condenser; Buzzer
for Test; Tuning Coil from Phonograph
Record; Tool List for Radio Fans; Use of
Ammonia to Stop Battery Acid Stains.... 7
Radiophone Broadcasting Station Directory
and Station Schedules—List, Correct to
Date, Gives 276 Stations in 39 States.... 8-9
Record Receiving Contest Starts with First
Record Holders Announced..... 9
Radio Telephony for Amateurs and Begin-
ners, by Peter J. M. Clute, Part II, "Ra-
dio Transmitting Stations"..... 11
Characteristics of Vacuum Tube Amplifiers,
by Benjamin F. Miessner, Part V of
Series, "Three Electrode Tube in Radio
Circuit" 12
Simple Instructions for Beginner, by Harry
J. Marx, "Use of Telephone Jacks and
Plugs" 13
Diagrams and Hook-Ups (Loose-leaf Sheet). 14
EDITORIALS
One of the Seven Modern Wonders; Will
Radiophone Chase Out Jazz? Radio and
Wire Phone Not Alike; Fad Not the
Proper Name; Indi-Gest Humor Column. 10

Standards Calls Fans' Attention to Fire Regulations

Special to RADIO DIGEST

WASHINGTON, D. C., May.—Radio fans should give heed to fire insurance rules in connection with the "hooking-up" of radio equipment. Otherwise the rates on their properties may be raised or the insurance refused entirely, warns the Bureau of Standards of the Department of Commerce in calling attention to the fact that fire insurance regulations governing the installation of Radio apparatus are to be revised.

According to the Department of Commerce, the rule which has heretofore covered Radio installations is known as Rule 86 of the National Electrical (Fire) Code and in connection with a general revision of this code a change in this rule has been decided upon. The matter is being considered by a committee of the National Board of Fire Underwriters.

The Department of Commerce has prepared a mimeographed circular containing tentative requirements which have been suggested for adoption. It will probably be a matter of several months before the definite requirements are decided upon, but in the meantime anyone who has real use for the above mentioned circular may secure a copy by writing to the Bureau of Standards, Department of Commerce.

To Relay Invitations to Police Convention

A. R. R. L. Will Broadcast All Police Chiefs

The American Radio Relay League will broadcast an invitation to every chief of police in the United States to attend the Police convention in San Francisco during the week of June 19. The method used will be similar to the one used in delivering the governors' messages to the president recently.

The invitations will be broadcast some time between 10 o'clock and midnight June 3, 4 and 5. A designated station in each locality will transmit the message at ten words a minute. Amateurs of the nation are to copy the messages word for word and make a duplicate. One copy to be immediately delivered to the chief of police of each city or his representative and the other signed by him, is to be mailed to the traffic manager, A. R. R. L., 1045 Main St., Hartford, Conn., for a record. The name and call letters of the amateur delivering the messages are to be marked on the signed copy. After the message has been delivered it is the privilege of the receiving station to rebroadcast it at 10 words a minute, repeating each word twice.

The American Radio Relay League has requested the co-operation of every amateur in getting the message delivered and delivery recorded.

Do you know that the Radiophone business has increased 60,000 per cent within a year? The demand which called it into existence is as tremendous as it has been sudden.

X-Ray Doctor Patents "Inductive Amplifier"

New Device Used for Transmitting or Receiving

BROOKLYN, N. Y.—A new Radio invention which will not conflict with the much-discussed Armstrong feed-back circuit and which will yield a maximum of tone volume is claimed for a patent just applied for by Dr. Francis L. Satterlee of Flushing, L. I., famous X-ray expert.

The new device, which may be used either for transmitting or receiving, is described as an "inductive amplifier," the suggestion of Major General George O. Squier chief of the Signal Corps, who examined it recently in the inventor's laboratory. Its outstanding characteristics, according to the inventor, is its novel employment of Radio-frequency. Dr. Satterlee is extremely reticent, however, about discussing the invention.

Dr. Satterlee, who is a cousin of Herbert L. Satterlee, son-in-law of the late J. P. Morgan, gained considerable fame in his X-ray experiments, which attempted the application of the rays to the cure of cancer. As a result the doctor contracted cancer in his right hand and was compelled to have two fingers amputated.

The inventor will probably make further announcement within a short time, giving further details of the improvements which he hopes to make in Radio art. He has become so fascinated with his new pursuit that he will devote his entire time to it hereafter.

CANADA IMPOSES TAX ON RADIOPHONE SETS

Aerials Are Sign Posts for Tax Collectors

WINDSOR, CANADA.—Radio fans in the Windsor district now number several thousand, according to figures compiled by Sergeant A. Birtwhistle, of the Royal Canadian Mounted police. He is responsible to the Dominion government for the collection of license fees for amateur experimental Radio sets.

More than 500 applications for licenses have been sent to Ottawa by border residents. Some of these applications, the sergeant said, have been returned because the necessary \$1 was not included.

Collection of license fees is difficult, because many of the receiving sets owned along the border are operated without aerials. Only a house-to-house investigation will determine the exact number of Radiophone owners, Sergeant Birtwhistle said.

Applicants for licenses are required to get in touch with the Dominion naval service at Ottawa. Prosecutions will follow unless applications are filed within 10 days of the sets being installed.

given to
quirer's,
my, line
undertaking
The currents
electric wires and
coil as in Major
ion. By the use
ected to the wave
s to the ground."

Squires, Dr. Cohen and
were the army repre-
United States Inter-
Committee on Radio

Telegram that was held in Paris last
summer.

NORWAY MOUNTAIN TO HAVE STATIONS

New Equipment Gives Range of 3,000 Kilometers, Reaching America

Special to RADIO DIGEST

WASHINGTON, D. C., May.—The wireless station on the Rundemanden, a mountain towering 2,500 feet over the city of Bergen, Norway, is being modernized and equipped with more powerful apparatus as well as with wireless telephone apparatus, according to a dispatch received by the Department of Commerce from Bergen regarding the wireless station on the Rundemanden. The report continues:

"The equipment to be installed has a radius of 3,000 kilometers and it is believed that direct communication with American wireless stations will be possible. Wireless telephones with an 800 kilometer radius are also to be installed and wireless telephone connections with England and continental Europe established. These improvements are estimated to cost about \$25,000 and are to be completed by June 1. The work will be carried out by the A. S. Telefunken, a Norwegian corporation controlled by a German company of the same name."

RADIO SPEEDS PEACE WITHOUT CONFERENCE

Owen Young Sees Great Hope in Airphone

NEW YORK.—Owen Young, chairman of the board of directors of the Radio Corporation of America, said recently that International peace will be more certainly maintained by the constant use of Radio communication than by all the conferences that the people of the earth may devise.

Mr. Young has been abroad attending the four-power Radio conference between England, France, Germany and the United States, held at Cannes. He said that the amenities between the nations could be preserved if there were continual conversation between and among men. He thought the best way to do this was with Radio.

Looking Ahead

- The Aerial and the Ground. The Third Article of Series by Peter J. M. Clute.
- New Receiving Set Ultimate in Simplicity of Operation and Design. Promises to Revolutionize Sets Now on Market. Watch for This.
- Instructions for the Beginner. Another Article by Harry J. Marx, Written in His Easily Understood Style.
- "How to Make" Department. Kinks to Keep the Home Workshop Busy.
- Broadcasting Directory. The Only Complete, Correct Station and Schedule List. Growing Every Week.
- Famous Broadcasting Stations You May Have Heard. Weekly Pictorial Shows New Stations.
- Live News of Radio Every Week.

BE SURE TO GET RADIO DIGEST

It Will Be Hard to Find a Copy on the News Stands

SUBSCRIBE NOW!

SEND IN THE BLANK TODAY

Publisher,
Radio Digest, Illustrated,
123 West Madison St.,
Chicago, Illinois.

Please find enclosed check M. O. for Five Dollars for One Year's Subscription to Radio Digest, Illustrated.

Name.....

Address.....

City..... State.....

MOVIE PRODUCERS USING AIRPHONES

TROUPES CARRY STATION ON FAR "LOCATIONS"

Players "on the Lot" Listen in on Set as a Diversion Between Scenes

HOLLYWOOD, CAL.—Motion picture producers have found a great practical use for the Radiophone.

The time is not far distant when the Airphone will be as important to the movie maker as the arc light or the camera.

Experiments already made by Marshall Neilan, the young producer who has introduced various innovations in the production of pictures, indicate that Radio will play a vital part in future picture making.

The first practical phase of the Radiophone employed by Mr. Neilan as directly affecting motion picture production was its use as a medium of keeping in constant touch with his companies on "location." Over six months ago Mr. Neilan experimented with the airphone in the direction of players on a distant "location," from his office at the studio.

This proved such a wonderful improvement over using telegrams and long distance telephone that it practically gave the producer twice the amount of time for business each day. In other words, he can attend to business matters at the studio and keep in touch with his players and assistant directors whether they are on an island in the Pacific or in the distant mountains surrounding Hollywood.

Thus each Neilan troupe, when it goes on location, carries with it a complete station and keeps in hourly touch with its chief at the studio. A producer who either personally directs or supervises the important situations in every production, can now, through the Radiophone practically direct his players from his office. The use of the Airphone in staging big battle scenes or mob scenes for the movies has also been found a big asset. Instead of communicating with assistant directors who have charge of movie armies at distant points, the director sits with his cameramen at the principal point of the scene's action and by means of the amplifier, is enabled to instruct every player direct at distant points.

Another practical use to which producers have put Radio at their studios is the employment of a receiving set as a means of diversion for the players who spend many hours "on the lot." In many productions the producer is working night and day. This means that the players have many hours of idle time on their hands around the studio when not actually appearing before the camera in certain scenes.

In the past the phonograph was used to entertain the players while not actually working on the "set." Mr. Neilan has installed a receiving set with a large amplifier on an adjoining stage where players congregate and receive news bulletins, music recitals and operas in their leisure moments. This keeps the morale of the players in good shape, especially when they spend from nine to fifteen hours at the studio without any other form of relaxation.

"Many practical uses will be found for the Radiophone in the movie world," said Mr. Neilan in discussing the matter recently. "Already I have found this wonderful instrument, which has taken the country by storm, a method of saving much time and expense in movie making. It will not be long before every studio will find the Airphone as important to its equipment as the arc light or the camera."

Radiophone to Entertain Tourists
GLACIER PARK, MONT.—The Glacier Park Hotel Company are making extensive preparations for the installation of Radio as a tourist amusement feature for this summer.

NEW YORK COUNCIL PLANS 1923 SHOW

NEW YORK.—Renville H. McMann, president of the Executive Radio Council of the Second District, announces that the council's next annual Radio show will be held the first week in March, 1923.

The plans call for taking one of the largest armories in the city so that all visitors and exhibitors can be comfortably accommodated.

Mr. McMann wishes it made clear that the Radio Council has no connection with any other exhibit.

COURT USES RADIO FOR ANNOUNCEMENT

SAN DIEGO, CAL.—There will be no need for lawyers to appear in the court-room to learn if court will convene for the day. They now use Radiophones here in department three of the Superior Court. Recently there was no way for the court house officials to inform San Diego lawyers that the court would be postponed for one week until they thought of the Radio broadcasting station. It was used to make the announcement.

LISTENING IN TO WILD RADIO WAVES RIVALS THE CALL OF THE OCEAN SURF



© K. & H. Pretty Miss Marie Devourak, a San Francisco mermaid, takes her set to the beach each day to hear the broadcasts

BROADCAST AIDS CHURCH AIRPHONE VARSITY RACES

Sermons Preached by Radio While Pastor Is Sick

WHEELING, W. VA.—The Radiophone has "stepped into the pulpit" of the Baptist Temple here, and services will be carried on as usual. The move was made necessary because of the illness of the pastor. With the installation of Radio in the church sermons will be received from Pittsburgh every Sunday morning during his illness.

Colleges Using Broadcasts to Report Relays

Colleges are now using the Radiophone to make reports on relay races. Two of such races were held recently at the Pennsylvania University and at the Drake University, Des Moines, Iowa. In both instances a broadcasting station was set up after getting the authority from Washington to transmit the results.

DUBILIER REVIEWS RADIO ACTIVITIES

BROADCASTS SUCCESSFUL AS EARLY AS 1911

Airphone Science Has Advanced Civilization Hundreds of Years, Says Inventor

"In 1910 and 1911 I had a laboratory in Seattle, Wash., where I was living at the time. One warm evening during July, 1911, I visited a West Seattle amusement park. I noticed an unusual sign which read:

"Listen to the Music, Vaudeville and Jokes by Wireless Telephone—10c," says William Dubilier, president of the Dubilier Condenser and Radio Company, of New York, in an interview in *Illustrated*. "But the place was shut up for the day as there was no operation on Sunday. So, being inquisitive and interested in Radio telephone work I visited the booth the next morning, where I found a disappointed youngster about my own age with another small sign

"Not Operating Today."

"As the wireless developments at that time were being conducted very secretly I was careful not to create any suspicion in asking questions, but I soon learned that this enterprising fellow was selling my music which I transmitted every evening from my experimental station. He merely put up a receiving set, tuned to my transmitting station and allowed visitors to listen to the receivers for a few moments at 10c a throw.

"About the same time I received a letter, dated July 20, 1911, from J. H. MacDonald, who was the wireless telegraph operator in the employ of the Canadian government at Point Gray, about 200 miles from Seattle, stating that it was very wonderful of me to break up his monotonous moments by giving him musical selections and entertainments.

"Thus was born in me the germ of broadcasting wireless music and entertainments to the public. I did not realize the possibilities—in fact no one with the broadest imagination could see then that the world would be revolutionized overnight by this new wonderful system of transmitting intelligence without wires.

"Six months ago probably 100,000 receiving sets were in use. Today it is conservatively estimated that over a million homes are entertained and educated by means of the Radio telephone. I know of no science which has advanced civilization in such a short period to an extent equal to the promising outlook of the Radiophone. It will annihilate distance entirely, so that the Japanese, Eskimos, South Americans, Icelanders and the Siberians will become neighbors and will soon adopt a common language, thus eliminating national hatred and distrust and possibly future wars. In the very near future one will be able to talk from his office or home, phone to his friend on a steamer in the middle of the Pacific or the Atlantic.

"The farmer will become cityfied, and the cartoons showing the country hotel with a stove in the center of the lobby, around which the local topics are discussed, will soon be replaced by a radio receiver and the deadening monotony will disappear. They may be listening to an opera or to a candidate for President, electing from his home, or to the news which formerly took a week to reach them.

"No woodsman or camper will be isolated, for pocket receiving sets will be developed, so that some day we will see the traveler throw a wire over a tree and listen to the news or be amused by a Broadway musical show. Every Pullman train will have its Radiophone and the stock news tickers are already being replaced by Radio receivers. Everything of interest will be broadcasted and every modern up-to-date apartment house will include in its service Radio entertainment

(Continued on Page 4)

THE ANTENNA BROTHERS

Spir L. and Lew P.

CELESTIAL MUSIC



EXPLAINS WORKING OF RECEIVING SET

ILLUSTRATION ON PAGE 5 SHOWS DE FOREST TYPE

Fifth Article of Diagram Series Indicates All Parts and Various Functions

(See Diagram, page 5)

The DeForest Inter-Panel receiver, built up of four units, one tuner, one vacuum tube detector and two vacuum tube amplifiers, is explained this week. The set is manufactured by the DeForest Radio Telephone and Telegraph Company of New York, and by the use of various sizes of primary and secondary honeycomb coils, is capable of receiving stations with from 150 to 27,000 meters wave length. This broad scope includes every wave length in use. With the two stages of amplification, a well constructed antenna and a good ground, its possibilities are great.

Explanation of Panels and Circuit

The circuit employed is a double primary, single secondary, triple honeycomb coil mounting, with primary vernier variable condenser arranged with switch so as to be placed in series or parallel, and a parallel secondary vernier variable condenser. The variable condensers provide the only variations in primary and secondary inductance, using three given honeycomb coils, but the additional variations for the wide range of wave lengths are obtained by use of various combinations of honeycomb coils, a table of combinations for which is given on this page. This much of the circuit is contained in the tuner unit, known as MT-200, and shown as the panel farthest to the right in the top, and farthest to the left in the bottom photograph on page 5.

From the secondary of the tuner unit, the leads go to the conventional vacuum tube detector circuit, all of which is contained in unit MP-100, the audion control panel, shown as first panel to left of tuner panel in top, and to right in bottom photograph, page 5. The control panel contains a variable grid leak and condenser, filament current control rheostat, plate current voltage control switch (gives variations of from 16½ volts to 22½ volts, 1½ volts each switch contact, increases as turned clockwise), receptacle for detector vacuum tube, and the tube itself.

To the left of the detector panel, top, and right, bottom photograph, on page 5, comes the first and then, second amplifier units, each contained in a separate panel. Each panel contains a filament current control rheostat, an audio frequency amplifying transformer, and two telephone jacks. When facing the front of the set (top photograph, page 5), the telephone jack shown in use gives two stages of amplification, while the jack farthest to the right gives use of the detector alone.

External Connections to Set

In setting up the set for use, directions for making external connections are simply explained by the photo-diagram. The aerial or antenna is connected to binding post A, and ground to E. The antenna for the set should consist of a single wire, 100 to 125 feet in length, over all, including length to point in actual contact with ground. For extra long wave reception, an antenna not less than 200 feet in length should be used. A good ground connection is essential. It is even more important than the antenna. Connection by means of ground clamp to a well scraped water or gas (preferably water) pipe on the street side of the meter will usually suffice. Soldered ground connections are best.

Three 22½ volt "B" or high voltage batteries, one of which should have taps at 16½, 18, 19½, and 21 volts, should be connected to the rear of the detector and amplifier panels shown in the diagram. Care must be taken to see that these are properly connected, watching the polarity on all leads. Lead wires to connect to the batteries are provided with the set. The "A" or filament lighting battery should be a six volt, 40 to 60 ampere hour storage battery and should be connected to the two binding posts on the left amplifier panel as shown in top photograph, page 5. Polarity must again be watched in making this connection.

Operation of Set

After insertion of proper tubes in the sockets in the back of the panel, with filament current sure to be turned off, and with telephone receiver plug in jack

"TEL No. 1" (farthest to the right), the filament rheostat, detector unit, is turned to the right slowly until the tube is burning at incandescence. The two amplifier tube rheostats should be on the "off" position. Then the proper size honeycomb coils are placed in the triple mounting. These are selected according to the chart reproduced on this page, depending on the wave lengths which are desired to be received. The chart also serves as a guide as to whether the condenser switch right panel, top photograph) should be thrown to the left in the "SERIES" position, or to the right in the "SHUNT" position.

The secondary coil selected should be placed in the center receptacle of the triple mounting, and the two primary coils selected in the two movable receptacles. Adjusting the movable coils so that the angle between each and the secondary coil is about 0 to 40 degrees, and with the primary condenser at zero, the secondary variable condenser is turned until the signal is heard the loudest. The primary condenser is next turned until the signal is loudest. Then the angles between the two primaries are adjusted to eliminate interference, and the two condensers re-adjusted. The greater the angle between the primaries and the secondary, the sharper the signals will tune, and the less will be the interference from other stations.

Having adjusted the tuner panel satisfactorily, finer adjustment of the detector unit is to be made. Now the switch varying the plate voltage is adjusted until the signals are loudest. Next, the rheostat controlling the detector filament current is more finely adjusted.

Varying Grid Leak Resistance

At this point, should a sound resembling the throbbing exhaust of a gasoline engine be heard in the telephone receivers, and which cannot be eliminated by manipulation of the "B" battery switch and the detector filament lighting rheostat control, the grid leak resistance needs adjustment. This is done by removing the nickel plated cap (turn to left a little and pull) and by drawing soft lead pencil lines between the two brass screw heads until the noise is just eliminated. Too many pencil lines make the tube insensitive, in which case the excess can be removed by means of an eraser.

Now the telephone receiver plug is removed from the jack it is in, and put in the jack farthest to the left. The amplifier filament control rheostats are next turned on until both filaments are incandescent at the proper brilliancy. Too much brilliancy here indicates an excessive current and means a material shortening of the lives of the tubes. The amplifier rheostats should be adjusted for maximum brilliancy of tube filaments.

HONEYCOMB COIL CHART FOR DE FOREST MT-200 TUNER

Wave Length Range	Primary Coils (2)	Secondary Coil (1)	Primary Condenser
150-355	50	25	Series
305-710	100	50	Series
460-1050	150	100	Series
835-1950	250	150	Series
1760-4000	500	250	Series
3950-8450	1000	500	Series
6000-12500	1500	1000	Series
12000-20000	1000	1500	Shunt
16000-25000	1500	1500	Shunt

TU-WAY

New design plug, jacks, variable condenser, V. T. socket, rheostat & head sets. If your jobber is unable to supply, write us



DUBILIER REVIEWS

(Continued from page 3)

and news, the same as hot water and steam heat now supplied. Radio universities will be created and regular lectures and courses given.

"The advertising value of broadcasting is enormous and the public will benefit, for no longer will they be able to force you to look through the newspapers and publications between the advertisements for the news, but the stores and the political candidates will hire the finest talent to amuse you, as an inducement to listen to their personal stories.

At last the public has found a means whereby it will be difficult to force propaganda down one's throat and the keen competition that broadcasting will soon give the newspapers will compel them to give the public unbiased news. The big vaudeville circuits have already issued orders preventing their artists from singing for broadcasting stations—amongst them is Keith's. The result of this will be that favored and inefficient artists will no longer be tolerated.

"And so we can go through almost every important phase of life which will be affected in some way by broadcasting, which is establishing itself as a keen competitor to practically every public educational or amusement service: such as the newspapers, theaters, telephones and telegraph companies, mediums for political propaganda, religious institutions, etc.

Headquarters for

Radio Supplies and Equipment

Radio Department
COMMONWEALTH EDISON ELECTRIC SHOP
72 West Adams Street
Chicago, Ill.

210 Amp. Hr. Radio Batteries Exide and U. S. L. Navy Type

Special \$20

Original Cost \$89.50. On Sale
Mail Orders Promptly Shipped

C. W. HANIKA
15th Street Public Market

15th and Jefferson Streets
Phone Canal 0573 and 0576

also at
5336 LAKE PARK AVENUE
Phone Dorchester 3376

or
1113 ROOSEVELT ROAD
Phone Canal 1440
CHICAGO, ILLINOIS

Naco Radio Receiving Sets \$20 Complete Without Condenser

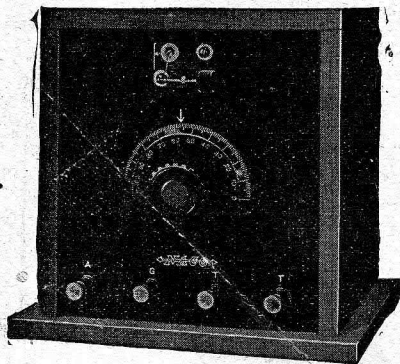

For clear hearing and pleasing tone use a NACO set

NACO Radio Accessories

STATE MANAGERS WANTED

"We are building our radio business for the future, not only for today. Courtesy and discretionate prices prevail"

National Motor Accessories Corporation
1446-1448 Woolworth Building, NEW YORK CITY

THOS. E. WILSON & Co.

Radio Department IN STOCK TO-DAY

A Fresh Shipment of De Forest Radio Sets

De Forest "Every Man" Radio Set, complete with Head Phones \$25.00

De Forest Radiohome Vacuum Tube Detector Set. Complete with Detector Tubes, Frost Head Phones, "Am-Plus" Storage Batteries, "B" Battery and 100 Feet Aerial Wire..... \$64.00

"Air Way" Variocouplers \$4.50

"Air Way" Variometers \$4.50

RHEOSTATS

The "Bradley Stat." Finest filament rheostat made..... \$1.85

Advance filament rheostat, 3 ohm \$1.25

Advance head sets, 6 ohm \$1.50

HEAD SETS

"Penberthy" head phones, 3000 ohm. Pair..... \$10

Western Electric head phones, 2200 ohm. Pair..... \$12

Frost head phones, 3000 ohm. Pair \$6

Variable Condensers (High Grade)

11 plate, \$3.50; 23 plate, \$3.85. 43 plate \$4.25

Binding posts, Each 10c

Switch contact points, Dozen 35c

Tested Galena or Radiocite Crystals, mounted, 40c; unmounted..... 25c

Crystal detectors. Complete \$1.25 & \$2.75

Thordarson Amplifying Transformers \$4.50

Air Way Amplifying Transformers \$3.00

B Batteries, Aerial Wire, Magnet Wire, Lightning Arresters, Switch Levers, everything for assembling your own set at lowest market prices.

THOS. E. WILSON & Co.

42 South Wabash Avenue
Dept. R. D. Chicago

Radio Book

Rogers instructions in Radio, what it is, and how to understand it.

PRICE 25 CENTS

Ambassador Radio Company
Los Angeles, California

safe radio

BRACH vacuum LIGHTNING ARRESTER

For Your Radio

Why take chances with any other, when you can get the Brach Vacuum Lightning Arrester that has long been recognized by the United States Army, by the big railroads and telegraph companies, by fire departments—and, finally by the National Board of Fire Underwriters.

The Brach is a fool-proof lightning arrester—works automatically. You can go away and forget it.

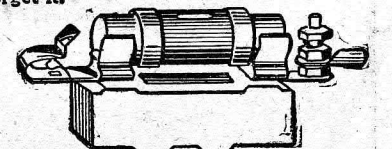

Your Dealer Will Supply You
L. S. BRACH MFG. CO.
Newark, N. J.

16 Yrs. Specialists in Lightning Protective Apparatus

RADIO SUPPLIES STORES

Prompt Service—Quality Goods—Priced Right

Radio Division
TELEPHONE MAINTENANCE CO.

20 S. Wells St. Franklin 3986
5206 W. Madison, Austin 7041, 1122 E. 47th St.

Look for the TELMACO Sign

Radio Receiving Sets

The How of De Forest Inter-Panel Set

The De Forest inter-panel receiving set, consisting of honey-comb coil tuner No. MT-200, detector unit No. MP-100, and two audio frequency amplifier units No. MP-200, is explained diagrammatically below by RADIO DIGEST in its fifth chart on standard receiving sets. On page four, first column, will be found the explanation of the operation of the set here shown.

This receiver is manufactured by the De Forest Telephone and Telegraph Company, New York, and has, with proper honeycomb coils and antenna, a wave length range of from 150 to 27,000 meters.

Inasmuch as an understanding of one instrument will aid in the understanding of one of different make, the beginner should read this page and the accompanying explanation on page four carefully.



Antenna

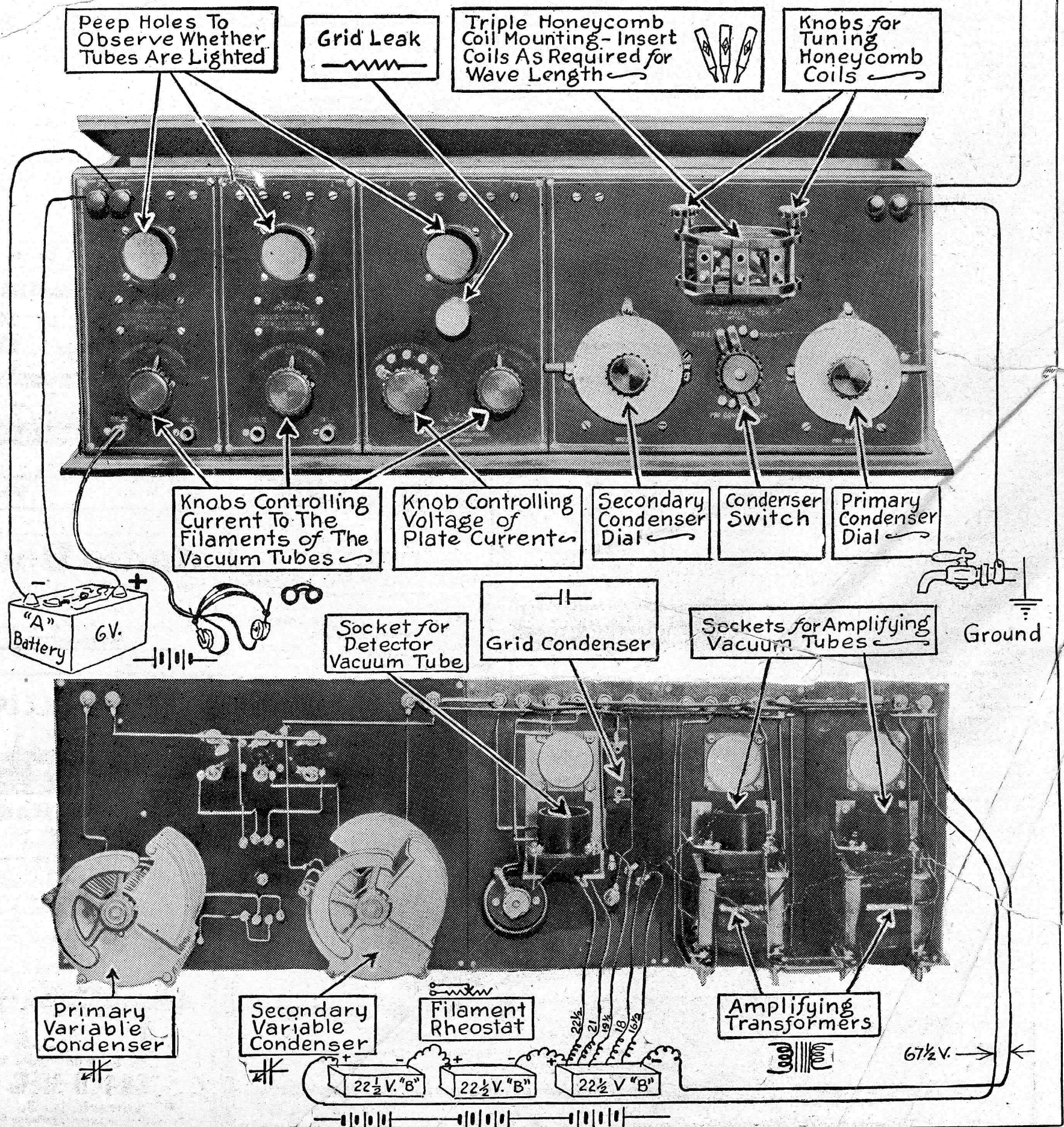

NOF, WAAK AND WBT HEARD FAR

Waldorf-Astoria Patrons Jazz to Pike Orchestra Music Sent Over WAAK

Half Million Get WBT

Concert Over NOF Is Heard by Wounded Soldiers in Six Cities

Milwaukee has hopped into the Radio-broadcasting bandwagon with station WAAK located in the Gimbel Brothers' department store. This station started operating on April 27 with a concert by the

Charlotte, North Carolina has become the "Arlington of the Southeast," according to the News in commenting on station WBT located in that city. The set is operated by The Southern Radio Corporation and is reaching an estimated nightly audience of over a half-million people in a 500 mile circle from Charlotte.

"Music is of course not all that is heralded through wave lengths out of Charlotte over WBT to the various points of the compass," writes Julian S. Miller of the News. "Oratory is offered also, as a part of programs calculated to interest and to inspire those from afar who are not permitted to sit in the studios and hear the resounding reverberations of song or to be enchained by the eloquence of notable speakers. The weather forecasts are sent out over a far-flung territory every morning at 11 o'clock. For the department of commerce in Washington, the local agency sends out also throughout the Southeast market reports and crop conditions touching upon cotton and its by-products, such

wide distribution. The company is preparing to gather up the very best talent of the community, of every description, the best vocalists, the best instrumentalists, the best sermons, the best speeches, the best of everything that is delivered from the lips of the people of Charlotte, for the purpose of providing its audience of a half-million with their genius, either of eloquence or of melody.

"When a program is ready to be delivered from Charlotte, somebody whispers the simple announcement that 'This is W. B. T., located at Charlotte, N. C.,' and instantly the receivers go down. Or that is what they would do if the transmission was via the wire-and-pole process of telegraphy and telephony, but radio has no wires stretching from town to town. It has nothing but wave-lengths and wave-lengths are neither handleable nor visible. They simply exist somewhere above us, but with their intangible tentacles they are reaching out and picking up the voices of men and speaking them into the ears

Heard in Canada

"A letter just received from St. Catharines, Ontario, by officers of the Southern Radio Corporation announced the perfect hearing there of the program sent out from Charlotte on a night in May, consisting of a speech and a musical rendition.

"Your station has all the clearness and volume of that of the General Electric Company at Schenectady, N. Y.," says a letter from Fort Dupont, Delaware.

"Springfield, Mo.; Corinth, Miss.; Arkadelphia, Ark.; Columbus, Ohio; Saginaw, Mich.; Wellsville, N. Y.; Arkport, N. Y.; are some of the most distant points from which information has been received here of having clearly heard the programs sent out from Charlotte through W. B. T.

"All of these points are far beyond the range of the wave-lengths for which the Charlotte station is fitted to utilize in dissemination, and are taken to indicate that this is one of the best equipped and one of the most expertly manipulated in the whole country.

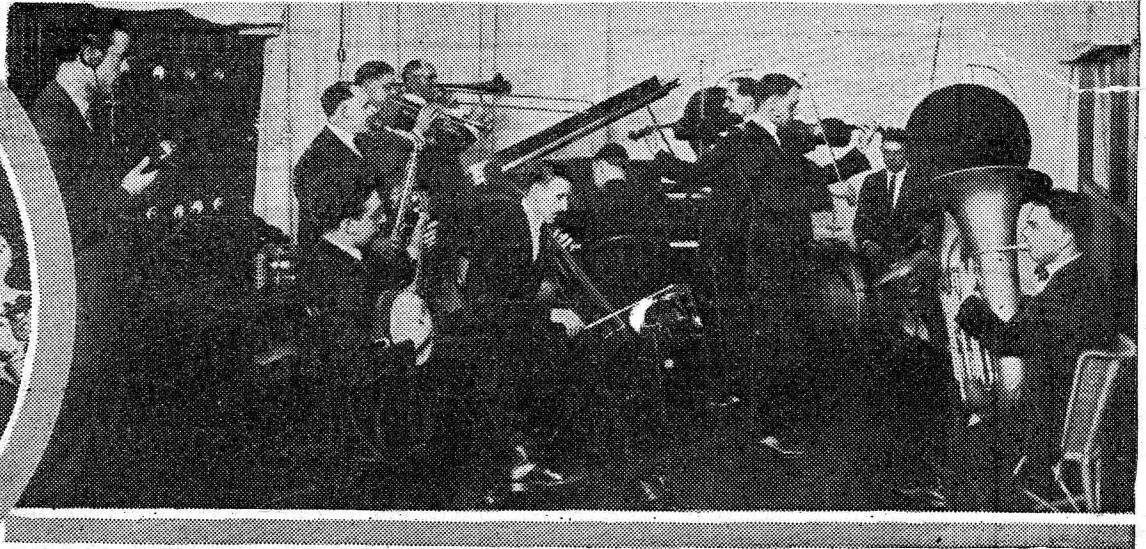

© U. & U. (Above) Fred W. Pike and his all-star orchestra broadcasting over Milwaukee Station WAAK. (Insert) Opera singers giving concert for shut-in soldiers over NOF, Naval Radio Station at Anacostia, D. C.

famous Fred Pike orchestra. WAAK was the first licensed broadcasting station to operate in Wisconsin. On the experimental test the sending was so perfect that the music was picked up by fans all over the country. A congratulatory wire was received from the Waldorf Astoria, New York city where the fancy jazz music of the Pike orchestra was enjoyed by the hotel tea room patrons.

WAAK is furnishing a regular daily program to the Wisconsin fans. Before its installation the only stations to be heard were those located out of the state. The program includes every day a rendition by the Pike orchestra at 3 o'clock in the afternoon. Both the station and Pike are making Milwaukee "doubly famous."

market reports as are of especial interest throughout the cotton-growing country.

"These are some of the regular, stated programs of the local corporation in its present state of development. It has completely fitted out a handsome studio in the Andrews music store, where the musical programs are collected for distribution, wires having been connected with the sending station in the Realty building from the studio. In addition the First Baptist church has been wired and the Sunday services sent out twice each week. Other churches of the city, some of them at least, are to be connected for the same purpose and wires have been run into the Chamber of Commerce to collect the programs that are so frequently given there for South-

of a multitude miles apart. Thus it is that W. B. T. of Charlotte, has become in less than a few months not a mere plaything to gratify the fancies of a few scientists nor to entertain the romantic notions of the experts, but an institution fitting into the social and civic and economic life of this whole city and of this whole State. This station as a nightly audience of 500,000 people. That number in the territory through which these wave-lengths penetrate are equipped with instruments for taking in what is from here sent out and judging from the letters and telegrams and other sorts of messages from 'the audience,' the local sending station is functioning with a degree of success denied many of the other of the greatest stations of the country.

"The Radio development here has been so swift that it has all come about without popular appreciation either of what has already been done or what it is possible to do with it. The time is coming when the community will undoubtedly want to utilize this agency for the community's own advancement instead of as a mere gratification of curiosity. When one approaches the possibilities of Radio transmission, one is approaching the unknown quantity. We can only feebly sense what may come to pass, as every-day occurrences, in the common exchange of business communications, in the extension of political and industrial as well as social interests."

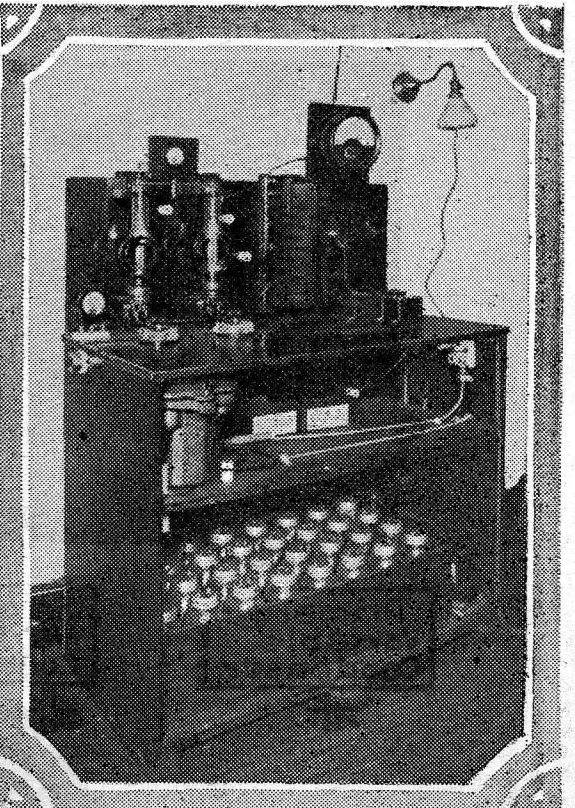

Showing studio and set of famous southern broadcasting station WBT at Charlotte, North Carolina. This station is heard by 500,000 people every day

How to Make a Fixed Feed Condenser

Construct Sockets for Vacuum Tubes at Home

If you are making your own apparatus for a receiving set it will be necessary to have one or more sockets for the tubes. These sockets are easy to make at home, just as easy as any part of the outfit. The illustration shows a simple method of constructing one of these sockets. The materials required are four binding posts, a brass hook, a block of wood and four brass strips.

The block of wood, when finished should be about one-half inch thick. To make the large hole without splitting the wood, bore a hole in a large piece of wood first, then cut the outside down to make it two and one-half inches square.

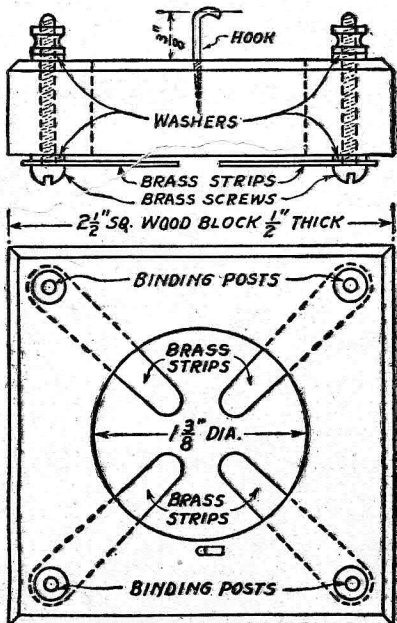

The contacts to the bottom of the tube are made of spring brass and are bolted onto the block from the bottom through the binding posts which serve as terminals.

USE WAX RECORD FOR COIL BASE

The writer, through ignorance of the use of a fixed condenser, stumbled upon a hook up which gave better service on a galena detector set than any so far published. Very likely the hook up has never been published because technical men say they cannot see the reason for the results it gives. The hook up consists of a small fixed condenser (.00025 mfd.) and a small homemade tuning coil, connected in series and shunted across from the aerial to the ground wire.

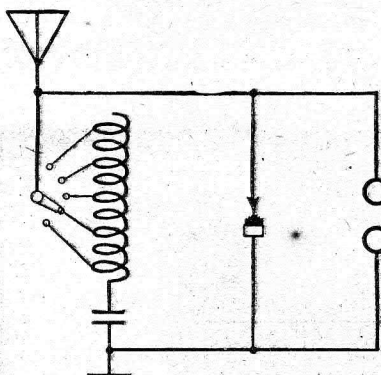

I live within a half mile of a rather powerful broadcasting station and was unable to use the tuning coil in the ordinary way because it did not have sufficient resistance to prevent the current shorting when the coil was hooked across the aerial

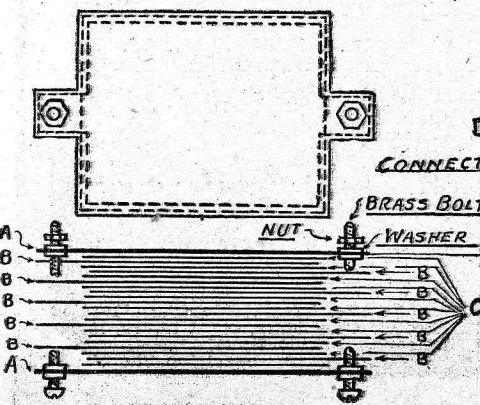

Proper Honeycomb Coils for Various Wave Lengths

The table shows the proper lengths of wire to use in the primary, secondary and tickler coils to obtain the listed wave lengths.

Wave Lengths Meters	Primary Coil Turns	Secondary Coil Turns	Tickler Coil Turns
200—450	50	25 or 50	75
400—825	150	100	100
800—1850	200	150	100
1500—2750	300	200	150
2500—4200	200	300	150
4000—6350	300	400	200
6200—14500	1250	750	400
13000—20000	750	1250	400

and ground connections in the usual way. The coil is wound of No. 26 enameled wire, about 165 feet, on an old cylindrical phonograph record, with a 14-point switch mounted on one end and binding posts on the other end. The diagram of the hook up follows.—E. C. Plouman.

short circuit would exist and cause an excessive current to flow.

If the ground wire is connected to a water pipe, connect one test tip to the ground and the other to the gas pipe, which is also grounded. The buzzer should buzz if one has a good low resistance ground.

USES BUZZER TO TEST SET

If a buzzer and battery are available they can be used in testing for an open circuit. By connecting the battery and buzzer in series with the test clips or tips any low resistance circuit can be tested.

Leakage usually exists between the antenna and the ground. An antenna should be well insulated from its support. The lead-in should be brought down to the point where it enters the wall of the station in such a manner that when the wind causes it to swing it cannot touch any grounded material, and that rain and snow

Radio Kinks

RADIO DIGEST is interested in any of those little kinks that every amateur discovers in his workshop. Sometimes it's a How to Make Article, or a little tip in operation of the set, how to use parts that are not thought of, perhaps some new hook-ups that haven't been published yet.

Send them in, with full details, sketches and diagrams if necessary. One Dollar will be paid for every one published. If a self-addressed, stamped envelope is included, rejected copy will be returned. Work must be original, however, and not copy from others.

RADIO KINKS DEPARTMENT, RADIO DIGEST
123 West Madison St., Chicago, Ill.

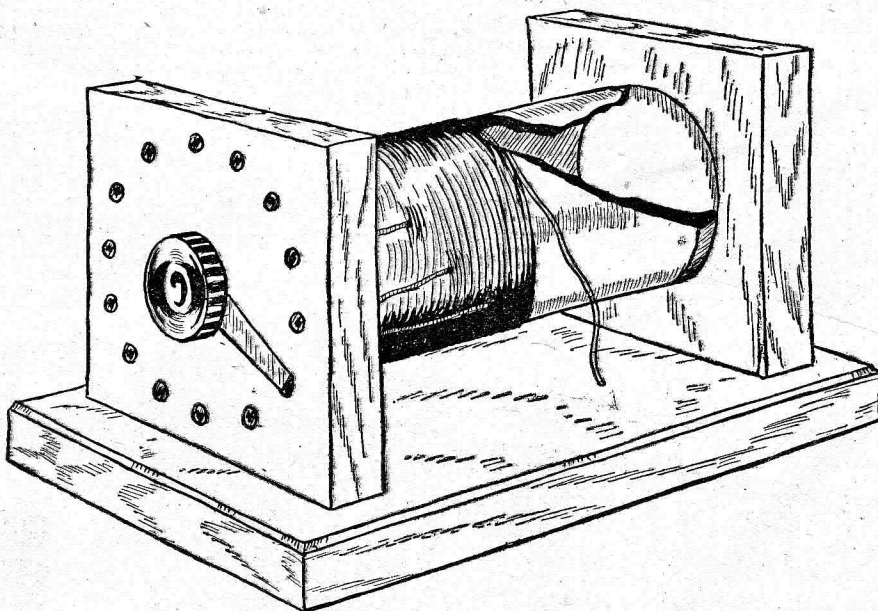

The ground connections can be tested with a buzzer and battery, but do not use the house-lighting circuit to test for grounds because one side of the lighting circuit is already grounded, and if the other wire were connected to the ground a

cannot cause a path along which the current can ground. In bringing the lead-in through the wall, insulate it well and inside the station use as short a piece of insulated wire as possible to make good connection with the set.

Materials Inexpensive for Making Condenser

When connecting up receiving sets a small fixed condenser is placed across the telephone terminals. This acts as a stopping condenser. Fair results may be obtained without the condenser where there is a small set. These condensers are easily made and the materials are inexpensive. The materials necessary to make a condenser, as shown in the illustration, are as follows: One piece of wood 3 3/4 by 6 inches and 1/2 inch thick; two pieces of cardboard 3 1/4 by 5 3/4 inches; ten sheets of tinfoil 3 by 4 1/2 inches; eleven pieces of waxed paper 3 1/4 by 4 inches; two binding posts; four pieces of tin sheet brass and some vaseline.

Cut the eleven sheets of waxed paper to the dimensions shown in C, then cut the ten pieces of tinfoil to the shape and dimensions as given in B, and then cut two pieces of cardboard like the pattern A. Be careful to have the measurements as given in the drawing.

One piece of cardboard A is placed on a level surface, a work bench or table top, and a thin coating of vaseline is spread on the surface with the tips of the fingers. Use just enough of the vaseline to hold the first sheet of waxed paper in place. The first sheet of waxed paper is placed on the cardboard and its surface is greased just as was the cardboard. The first sheet of tinfoil is placed on the greased surface with the 3/8 by 3/4-inch projection extending at one end. Continue piling up the pieces as shown in the sectional view until all pieces are used. The end piece of tinfoil should have the projection extending at the opposite end. Continue greasing and piling the parts, making sure to alternate the projections on the tinfoil sheets.

The four pieces of sheet brass are used for washers. These are put in place as shown.

Make the wooden base and bore the holes for the binding posts. Press the condenser parts together firmly, then place it on the wood base. Locate and bore the holes. Assemble as shown in the illustration and it will be ready for connection in the receiving circuit.

The condenser may be connected directly to the base of another instrument as a tuning coil if desired instead of attaching to the wood base.

GIVE TOOL LIST FOR RADIO WORK

"You know a workman by his tools," is the old adage but it is not always true. You will often see a fine piece of work turned out with an old jack knife and a hammer. It is, however, more necessary for the average man to have tools than the real genius. Some of the tools necessary for the average man to work on Radio apparatus are as follows: One pair of 6-inch side cutting pliers; one pair of long nose pliers; a good ratchet screwdriver; a jack knife; small hammer; one soldering iron; half dozen clips for experimental work; one hand drill; one mill file; one sheet of No. 1 sandpaper; one small vise; one hacksaw; and a box of assorted machine screws. Have a box to keep these tools in so that they will not be lost.

Ammonia Will Prevent Battery Acid Staining Wood

For Radioists using a storage battery to light their tube filaments it is a wise precaution to keep a bottle of diluted ammonia solution and an old cloth handy. This applies especially if the Radio set is in the parlor and where there are polished floors and furniture. As many storage batteries have wooden cases, some of the acid may splash over the sides and soak in the case or run down the table or on the floor. Under such circumstances quick application of the ammonia will neutralize the acid and prevent stains on the woodwork.

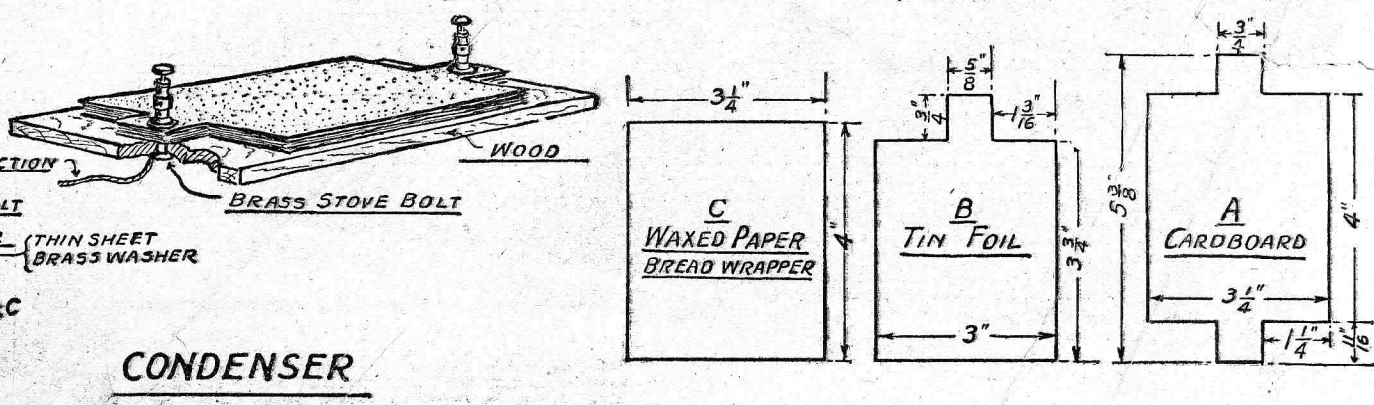

CONDENSER

Radiophone Broadcasting Stations

Corrected Every Week.

State and City	Call	Wave Lengths	Miles Range
Alabama:			
Birmingham	WSY	360
Montgomery	WGH	360	1,000
Arkansas:			
Fort Smith	WCAC	360	200
Little Rock	WSV	360
Pine Bluff	WOK	360	1,000
California:			
Altadena	KGO	360
Bakersfield	KYI	360
Berkeley	KRE	360
Berkeley	KQI	360
El Monte	KUY	360
Eureka	KNI	360
Fresno	KMJ	360
Gridley	KFU	360	500
Hollywood	KGC	360	300
Long Beach	KSS	360
Los Altos	KLP	360	1,500
Los Angeles	KNX	360
Los Angeles	KJC	360
Los Angeles	KNR	360
Los Angeles	KNV	360
Los Angeles	KON	360	200
Los Angeles	KUS	360
Los Angeles	KWH	360
Los Angeles	KXS	360
Los Angeles	KZI	360
Los Angeles	KJS	360
Los Angeles	KOG	360	300
Los Angeles	KQL	360
Los Angeles	KYJ	360	1,000
Los Angeles	KZC	360
Los Angeles	KFI	360
Los Angeles	KHJ	360
Los Angeles	KNN	360
Modesto	KOQ	360
Modesto	KXD	360
Monterey	KLN	360	150
Oakland	KLX	360
Oakland	KLS	360	150
Oakland	KZM	360	200
Oakland	KZY	360	1,500
Pasadena	KDYR	360
Pasadena	KLB	360	300
Pomona	KGF	360
Readley	KMC	360	150
Redwood City	KDYN	360
Sacramento	KVQ	360	1,000
San Diego	KDYM	360
San Diego	KDYO	360
San Diego	KDPT	360
San Diego	KYF	360
San Francisco	AGI	360; 485	50
San Francisco	KDN	360; 485	250
San Francisco	KGB	360
San Francisco	KSL	360	50
San Francisco	KPO	360
San Francisco	KUO	360	1,500
San Jose	KQW	360
San Jose	KSC	360
Stockton	KJQ	360
Stockton	KWG	360	1,000
Sunnyvale	KJJ	360
Colorado:			
Colorado Springs	KHD	200; 485	100
Denver	9WD	235
Denver	DD-5	340	1,500
Denver	KLZ	360; 485	1,000
Denver	KOA	485
Connecticut:			
Greenwich	WAAQ	360	600
New Haven	WCJ	360
District of Columbia:			
Washington	WMV	360
Washington	WDM	360
Washington	WDW	360
Washington	WJH	360	250
Washington	WWX	1,160	600
Washington	BYN	360
Washington	WPM	360
Washington	WIL	360
Florida:			
Jacksonville	WCAN	360
Georgia:			
Atlanta	WGM	360
Atlanta	WSB	360	1,000
Atlanta	4CD	200; 375
Atlanta	WAAS	360
Illinois:			
Chicago	WGU	360
Chicago	KYW	360; 485	800
Chicago	WBU	360	1,000
Chicago	WAAF	360; 485
Decatur	WCAP	360
Decatur	WBAO	360
Peoria	WBAE	360
Tuscola	WDZ	360	70
Urbana	WRM	360; 410	200
Indiana:			
Anderson	WMA	360
Indianapolis	WLK	360
Indianapolis	WOH	360	700
Richmond	WOZ	485	300
South Bend	WBAQ	360
West Lafayette	WBAA	370	100
Iowa:			
Ames	360
Davenport	WOC	360; 485
Des Moines	WGF	360
Iowa City	9YA	360

State and City	Call	Wave Lengths	Miles Range
Kansas:			
Eldorado	WAH	485
Emporia	WAAZ	360	250
Manhattan	WTG	360
St. Anthony	WBL	360
Wichita	WEY	260; 485	500
Wichita	WAAP	360
Kentucky:			
Louisville	9ARU	200	200
Louisiana:			
New Orleans	WCAG	360
New Orleans	WWL	360
New Orleans	WGV	360
New Orleans	WBAM	360
New Orleans	WAAC	360
New Orleans	WAAB	360
Shreveport	WAAG	360
Maine:			
Auburn	WMB	360
Maryland:			
Baltimore	WCAO	360
Baltimore	WKC	360	100
Massachusetts:			
Boston	WAAJ	360	50
Medford Hillside	WGT	360	500
Springfield	WBZ	360	500
Worcester	WCN	360
Michigan:			
Bay City	WTP	360
Dearborn	WVI	360
Detroit	WVJ	360; 485	1,000
Detroit	KPO	360
Detroit	WCX	360
East Lansing	WHW	485	150
Minnesota:			
Minneapolis	WCAS	360
Minneapolis	WAAL	360
Minneapolis	WLB	360; 485
Minneapolis	WBAH	360
Minneapolis	WBAD	360
Minneapolis	WCE	360
Redfield	WCAL	360
St. Paul	WAAH	360	200
Missouri:			
Columbia	WAAN	360
Jefferson City	WOS	485
Kansas City	WOQ	360; 485	300
Kansas City	WPE	360	300
St. Louis	KSD	360	1,000
St. Louis	WAAE	360
St. Louis	WCK	360	50
St. Louis	WEB	360
St. Louis	WEW	485	100
Nebraska:			
Lincoln	WCAJ	360
Lincoln	9YY	375	300
Omaha	WOU	360; 485
Omaha	WVO	360
Omaha	WAAW	360; 485
New Jersey:			
Camden	WPR	360
Deal Beach	2XJ	380
Jersey City	WNO	360	500
Jersey City	WAAT	360	70
Moorestown	WBAF	360
Newark	WAAM	360
Newark	WJX	360
Newark	2SAI	360
Newark	WOR	360	150
Newark	WJZ	360	1,500
Newark	WBS	360
Patterson	WBAN	360
Roselle Park	WDY	360
New Mexico:			
Roswell	KNJ	360	300
State College	KOB	360
Nevada:			
Reno	KOJ	360
New York:			
Albany	WNJ	360	60
Buffalo	WGR	360
Buffalo	WWT	360
Canton	WCAD	485
Newburgh	WCAB	360
New York	WBAY	360
New York	KDOW	360	1,000
New York	WVP	360; 1,450
New York	WWZ	360	200
New York	WDT	360
New York	WYCB	1,450
Rochester	WHQ	360; 485	50
Ridgewood	WHN	360; 485
Schenectady	WGY	360	1,000
Schenectady	WRL	360	800
Syracuse	WBAB	360
Tarrytown	WRW	360	1,500
Utica	WSL	360
North Carolina:			
Charlotte	WBT	360; 485	500

State and City	Call	Wave Lengths	Miles Range
Ohio:			
Akron	WOE	360	50
Athens	WAAV	360	500
Canton	WWB	360	50
Cincinnati	WLW	360	1,200
Cincinnati	WMH	360; 485	1,000
Cincinnati	WHK	360	100
Cleveland	WIZ	360
Columbus	WBAV	360
Columbus	8YO	275
Dayton	WFO	360; 485	300
Dayton	WA-1	360
Defiance	WCAQ	360
Fairfield	WL-2	360
Granville	WJD	360	100
Hamilton	WBAU	360
Hamilton	WRK	360	1,000
Lebanon	WPG	360
Marietta	WBAW	360
Toledo	WHU	360
Toledo	WJK	360
Toledo	WBAJ	360; 485	300
Youngstown	WMC	360
Youngstown	WAAV	360
Zanesville	WPL	360
Oklahoma:			
Oklahoma City	WKY	360; 485	500
Oklahoma City	5XT	360
Tulsa	WEH	360
Oregon:			
Hood River	KQP	360
Portland	KDYQ	360
Portland	KQY	360	100
Portland	KYG	360	700
Portland	KGW	360	200
Portland	KGK	360	500
Portland	KGN	360	500
Pennsylvania:			
Bridgeport	WBAG	360
Clearfield	WPI	360
Erie	WSX	360
Erie	WJT	360	1,000
Harrisburg	WBAK	360
McKeesport	WIK	360	500
Philadelphia	WCAU	360
Philadelphia	WFI	360	350
Philadelphia	WTP	360
Philadelphia	WGL	360	2,000
Philadelphia	WOO	360
Philadelphia	WPJ	360
Pittsburgh	WCAE	360
Pittsburgh	KDKA	360	1,000
Pittsburgh	KQV	360	750
Pittsburgh	WAAK	360
Pittsburgh	WPB	360
Villanova	WCAW	360
Wilkes-Barre	WBAX	360
Rhode Island:			
Pawtucket	10J	200
Pawtucket	1XAD	200
South Dakota:			
Rapid City	WCAT	360
Tennessee:			
Memphis	WKN	360; 485
Memphis	WPO	360	200
Texas:			
Austin	WCM	360
Dallas	WRR	360; 485	200
Fort Worth	WBAP	360
Fort Worth	WPA	360; 485	500
Houston	WCAK	360
Houston	WEV	360
Paris	WTK	360
San Antonio	WCAR	360
Utah:			
Salt Lake City	KZN	360
Virginia:			
Norfolk	WSN	360
Richmond	WBAZ	360
Washington:			
Aberdeen	KNT	360
Lacey	KGY	360	500
Seattle	KFC	360	700
Seattle	KHQ	360
Seattle	KJR	360	200
Seattle	KTW	360
Seattle	KZC	360
Spokane	KFZ	360	300
Spokane	KOE	360
Tacoma	WAAW	360
Tacoma	KMO	360
Wenatchee	KZV	360
Yakima	KFV	360
Yakima	KQT	360
West Virginia:			
Charleston	WAAO	360
Huntington	WAAR	360
Morgantown	WHD	360
Wisconsin:			
Milwaukee	WAAK	360
Madison	WHA	360; 485	600
Canada:			
Montreal	GAM	440	200
Toronto	450
Toronto	1,200
Hawaii:			
Honolulu, Waikiki	KGU	360

Your Directory—

To aid the beginner and to help him realize full benefits from his receiving station, RADIO DIGEST has compiled the accompanying list of radiophone broadcasting stations. To use the "radiophone directory" to its maximum advantage, the reader should note the broadcasting stations nearest, and attempt to tune them in at the wave lengths given.

Broadcasting stations with regular schedules of operating hours, are given below. Doubtless a few stations have been omitted inasmuch as their schedules have

not been reported to RADIO DIGEST. These will be added as reported. The kind of program broadcast by a station during its various operating hours is also given.

In fact, the reader, by means of RADIO DIGEST'S radiophone directory, can pick out his favorite program, the station he desires, or the time which he prefers to listen in. Time, in the following list of stations having schedules, is always given in the time used in the city in which the station is located.

The stations are listed alphabetically by call letters. The list, therefore, acts as an index to the foregoing table:

Station Schedules

- AGI**, Presidio of San Francisco, Cal. Signal Corps, U. S. A. Sun, 7-9 pm, instruction. Pacific time.
- DD5**, Denver, Colo. Fitzsimmons General Hospital. Daily ex Sun, 8:15 pm, weather, news, concert. Thurs, 8:15-9:30 pm, special concert, speech. Mountain time.
- GAM**, Montreal, Quebec, Canada. Marconi Wireless Teleg. Co. of Canada, Ltd. Daily ex Sat and Sun, 1-1:30 pm, concert. Mon, Thurs, 8-9 pm, concert. Eastern time, daylight saving.

- KDKA**, Pittsburgh, Pa. Westinghouse Elec. Mfg. Co. Daily ex Sun, 10-10:15 am, 12:30-1 pm, 2-2:20, 4-4:20, music; 7:30, bedtime story; 7:45, news; 8:30-9:30, music, news. Sat, 3-4 pm, concert. Sun, 10:45 am, 3 pm and 7:30, church service. Eastern time.
- KDN**, San Francisco, Cal. Leo J. Meyberg Co. Daily ex Sun, 11-12 am, 1-2 pm, 4:30-5:30, concert; 7-7:15, weather; 8:30-9, concert. Sat, nothing after 5:30 pm. Sun, 10-11 am, sacred concert. Pacific time.
- KFC**, Seattle, Wash. Northern Radio & Electric Co. Daily, eight hours, miscellaneous. Pacific time.
- KFU**, Gridley, Cal. Precision Shop. Mon, Thurs, Sun, 8-9 pm, concert. Sun, 3-4 pm, concert. Pacific time.

KFZ, Spokane, Wash. Doerr Mitchell Elec. Co. Daily ex Sun, 7:30-9:30 pm, concerts and voice. Pacific time.

KGC, Hollywood, Cal. Elec. Lighting Supply Co. Tues, Thurs, Sat, 7:30-8 pm, concert. Pacific time.

KGF, Pomona, Cal. Pomona Fixture & Wiring Co. Thurs, 7:30-8:15 pm, news, markets, concert. Mountain time.

KGG, Portland, Ore. Hallock & Watson Radio Service. Daily ex Sun, 4:30-6 and 7-7:30 pm, baseball scores, markets, news, Sat, 9-10 pm, instruction. Sun, 4:30-6 pm. Pacific time.

KGN, Portland, Ore. Northwestern Radio Mfg. Co. Daily, 12-1 pm, concert, lecture; 2:30-3:30, miscellaneous. Mon, Fri, Sun, 9-10 pm, health bulletin, concert. Tues, 7-7:30 pm, miscellaneous; 8-9, concert. Wed, Thurs, Fri, Sat, 7-7:30 pm, miscellaneous. Pacific time.

KGW, Portland, Ore. Ship Owners Radio Service Inc. (Daily Oregonian.) Daily, 3:30-4:30 pm, news etc. Mon, 7:30-8:30 pm, concert. Wed, 8-10 pm, concert. Fri, 8-9 pm, concert. Sun, 7-8 pm, church service. Pacific time.

KJJ, Sunnyvale, Cal. The Radio Shop. Tues, 8:15-9 pm, concert. Fri, 7:30-8:15 pm, concert. Pacific time.

KJR, Seattle, Wash. Northwest Radio Service Co. Daily ex Sun, 8-9 pm, miscellaneous. Pacific time.

KJS, Seattle, Wash. Northwest Radio Service Co. Daily ex Sun, 8-9 pm, miscellaneous. Pacific time.

KLB, Pasadena, Cal. J. J. Dunn Co. Mon and Fri, 7:30-8:15 pm, concert. Sun, 3-4 pm and 8-9, concert. Pacific time.

KLN, Monterey, Cal. Noggle Electric Works. Daily, 12-1 pm, weather, markets, news; 7-8 pm, concert. Pacific time.

KLP, Los Altos, Cal. Colin B. Kennedy Co. Mon, 7:30-8:30 pm, industrial news, concert. Thurs, 8:30-9 pm, concert. Sun, 4-5 pm, concert. Pacific time.

KLS, Oakland, Cal. Warner Bros. Daily, 12-1 pm, concert. Sat, 7:30-8:15 pm, concert. Pacific time.

KLZ, Denver, Colo. Reynolds Radio Co. Daily ex Sun, 7:30 pm on, news, markets, bedtime story, concert. Sun, 8-9 pm, church service. Mountain time.

KNJ, Roswell, N. M. Roswell Public Service Co. Daily, ex Sun, 7-9 pm, weather, financial, markets, news, Sun, 7-9 pm, church service. Mountain time.

KOA, Denver, Colo. W. H. Smith (Y. M. C. A.). Daily, 9:55-10:25 pm, time, weather reports. (Telegraph only.) Mountain time.

KON, Los Angeles, Calif. Holzwasser Inc. Daily ex Sun, 4-5 pm and 8:15-9, concert, news. Sun, 10-11 am, 4-5 pm and 8:15-9, church service. Pacific time.

KOV, Pittsburgh, Pa. Doubleday-Hill Elec. Co. Daily ex Sat and Sun, 4:30-5 pm, concert. Mon, Wed, Fri, 9:30-10:30 pm, concert. Sun, 1-1:30 pm and 4-5, concert. Eastern time.

KQY, Portland, Ore. Stubbs Elec. Co. Daily, 1-2 pm, 6-7, miscellaneous. Pacific time.

KQW, San Jose, Cal. Chas. D. Herrold. Wed, 7:30-8:15 pm, concert. Sun, 5-6 pm, concert. Pacific time.

KRE, Berkeley, Cal. Maxwell Elec. Co. Sun, 1-2 pm, 6-7 pm, concert. Pacific time.

KSD, St. Louis, Mo. St. Louis Post-Dispatch. Daily ex Sun, 4 pm, markets, news, concert; 7:45 pm, concert, lecture. Central time.

ESL, San Francisco, Cal. The Emporium. Daily ex Sun, 10-11 am, concert, news; 2-3 pm, concert, educational talk. Sun, 2-3 pm, concert and educational talk. Pacific time.

KUO, San Francisco, Cal. San Francisco Examiner. Daily ex Sun, 3-3:30 pm, and 5:30-6:45, news, etc. Sun, 5-6 pm, news, etc. Pacific time.

KVO, Sacramento, Cal. J. C. Hobrecht (Sacramento Bee). Daily ex Sun, 5:30-6:30 pm, concert, news, markets, weather. Wed and Sat, 8-9 concert. Sun, 5-7 pm, concert. Pacific time.

KYG, Portland, Ore. W. P. Hawley, Jr. Tues, Thurs, 9-10 pm, concert. Sat, 8-9 pm, concert. Pacific time.

KWG, Stockton, Cal. Portable Wireless Telephone Co. Daily ex Sun, 4-5 pm, news, concert, markets. Tues and Fri, 8-9 pm, concert. Sun, 2-3 pm, concert. Pacific time.

KYJ, Los Angeles, Cal. Leo J. Meyberg Co. Daily ex Sun, 4-5 pm, concert, markets, weather, news. Mon, Thurs, Sat, 8-9 pm, same program. Pacific time.

KYW, Chicago, Ill. Westinghouse Elec. & Mfg. Co. Daily ex Sun, 9:35 am-1:20 pm, market quotations every half hr; 2:15, news, markets; 3, baseball; 4:15 and 6:30, news, final markets and stocks; 7:30, baseball, bedtime story; 7:45, feature; 8-9, concert; 9, news. Sun, 3:30 pm, church service. Central time, daylight saving.

KZC, Los Angeles, Cal. Western Radio Elec. Co. Daily ex Sun, 5-5:30 pm, news, concert. Pacific time.

KZM, Oakland, Cal. Preston D. Allen. Daily ex Sun, 7:15-7:30 pm, news. Tues, 7:30-8:15 pm, concert. Fri, 8:15-9 pm, concert. Pacific time.

KZY, Oakland, Cal. Atlantic Pacific Radio Supplies Co. Daily ex Sun, 3:30-4:30 pm, concert; 6:45-7 pm, news. Wed, 7:30-8:15 pm, concert. Sat, 8:15-9 pm, concert. Sun, 11-12:15 pm, church service; 3-4 pm, concert. Pacific time.

WAAT, Jersey City, N. J. Jersey Review. Wed, 7-8 pm, concert, lecture. Sun, 7-8, church service, concert. Eastern time.

WAAJ, Boston, Mass. Eastern Radio Inst. Mon, Wed, Fri, 9-10 pm, concert. Eastern time.

WAAO, Greenwich, Conn. New England Motor Sales Co. Daily ex Sun, 9:30 am-5:30 pm, every half hr. Eastern time, daylight saving.

WAAZ, Emporia, Kan. Hollister-Miller Motor Co. Daily ex Sun, 9:45-1:15 pm, market quotations every half hr; 7-8 pm, concert, weather. Central time.

RECEIVING RECORDS? SEND THEM IN—

THE race is on! Amateurs who are able to beat the records listed below, or who can claim distance receiving records (100 miles or better) for stations not listed below, but which are given in the broadcasting directory, need only send in their records to be listed along with their names.

One condition exists. Every record aspirant **MUST GIVE** the NUMBER OF MILES represented by the record, if his letter is to be considered. Otherwise it will be thrown out.

Records to date are given below. —Broadcast Editor.

Station, Miles Record, and By Whom Heard.

DD5-790—T. E. Buchholz, La Grande, Ore.
 KDKA-870—D. G. Mickle, Red Oak, Ia.
 KFC-260—T. E. Buchholz, La Grande, Ore.
 KLP-800—T. E. Buchholz, La Grande, Ore.
 KLZ-790—T. E. Buchholz, La Grande, Ore.
 KNJ-1,150—N. M. Holmes, Chippewa Lake, O.
 KQW-600—T. E. Buchholz, La Grande, Ore.
 KVQ-520—T. E. Buchholz, La Grande, Ore.
 KWG-560—T. E. Buchholz, La Grande, Ore.
 KYJ-820—T. E. Buchholz, La Grande, Ore.
 KZM-570—T. E. Buchholz, La Grande, Ore.
 WGY-1,000—A. G. Carrie, Montgomery, Ala.
 WHA-900—J. B. Dusak, Worcester, Mass.
 WJZ-1,200—N. H. Schensted, Broomfield, Minn.
 WLB-600—Thos. Carr, Willard, O.
 WOH-900—A. W. Lee, Gardiner, Me.
 WWJ-2,200—F. W. Hill, Cristobal, C. Z.

WBAA, W. Lafayette, Ind. Purdue University. Fri, 7:15-7:45 pm, educational lecture. Other features irregular. Central time.

WBZ, Springfield, Mass. Westinghouse Elec. & Mfg. Co. Daily ex Sun, 7:30 pm, children's hour; 7:45, markets, weather, lecture; 8-9, concert. Sun, 3 and 8, church service. Eastern time.

WCK, St. Louis, Mo. Stix Baer & Fuller (Grand Leader). Mon, Wed, Fri, 6:45-8 pm, concert, lecture, bedtime story. Central time.

WDM, Washington, D. C. Church of the Covenant. Sun, 10:30 am, church service; 3 pm, lecture; 7:30, church service. Eastern time.

WDZ, Tuscola, Ill. James L. Bush. Daily ex Sun, every half hr, 8:30 am-12:15, Chicago Board of Trade quotations. Tues, Fri, 7-8 pm, concert, entertainment. Central time.

WEW, St. Louis, Mo. St. Louis University. Daily ex Sun, 10 am, weather, opening grain and live stock markets; 2 pm, closing of markets. Sat, 2 pm program at 1 pm. Central time.

WEY, Wichita, Kan. Cosradio Co. Wichita Beacon. Daily ex Sun, hourly, 8:40 am-12:40 pm, stock markets. Daily, 10:45 am and 4:30 pm, weather; 8-10 pm, baseball, concert, lecture; 10:45 weather. Sun, 8-10 pm, church service, concert. Central time.

WFI, Philadelphia, Penna. Strawbridge & Clothier. Daily ex Sun, 1:16 pm, news; 3:30-4:30, concert; 5:30-6, baseball. Mon, Fri, 6:30-7 pm, Radio talk. Wed, Fri, Sat, 7:30-8:30 pm, concert. Fri, Sat, (alternate weeks) 7:30 pm, concert at 8:30 pm. Sun, 4 pm, church service. Eastern time, daylight saving.

WFO, Dayton, O. Rike-Kumler Co. Daily ex Sun, 9-9:30 am, concert, news; 11-12 and 4-5 pm, concert, news, markets, weather. Mon, Wed, Fri, 7-8 pm, concert, lecture. Sun, 11-12 am, church service. Central time.

WGH, Montgomery, Ala. Montgomery Light & Water Power Co. Tues, Thurs, Sat, 11 am, weather; 4 pm, storm warnings; 8:30-9:30, concert, agricultural. Sun, 8:30-9:30, church service. Central time.

WGI, Medford Hillside, Mass. Am. Radio & Research Corp. Daily ex Sun, 2:55 pm, music; 3, news; 7:30, baseball, news; 7:45 pm, police reports. On Tues and Thurs, 7:30 and 7:45 pm programs at 7:45 and 7:55 pm, respectively. Sun, 8 am, church service; 8:45 am, sacred concert. Special features week nights, 7:30-9 pm. Eastern time.

WGL, Philadelphia, Pa. Thos. F. J. Howlett. Tues, Thurs, Sat, 7:45-11:30 pm, concert. Eastern time.

WGY, Schenectady, N. Y. General Electric Co. Daily ex Sat and Sun, 7 pm, markets. Tues, Thurs, Fri, 7:45-9 pm, concert, address. Eastern time.

WHA, Madison, Wis. Univ. of Wis. Daily ex Sun, 12:30-1 pm, weather, markets. Tues, Thurs, Fri, Sat, 12-1 pm, weather, markets, time. Tues, 8-9 pm, concert. Fri, 8-9:15 pm, news, concert. Sat, 1-1:20 pm, instruction. Central time.

WHK, Cleveland, O. Warren R. Cox (The Radiovox Co.). Daily, 1:30-2 pm, 3:30-4, miscellaneous. Tues, Thurs, Sun, 8-9:30 pm, concert. Eastern time.

WHQ, Rochester, N. Y. Times-Union, Inc. Daily ex Sun, 12-12:15 pm, news, concert; 7:30-8, markets, bedtime story, lecture; 8-8:30, concert. Sun, 3 and 7:30 pm, church service. Eastern time.

WHW, East Lansing, Mich. Stuart Wm. Seeley. Daily ex Sun, 11:30 am and 12:30 pm, weather and markets. Eastern time.

WIK, McKeesport, Pa. K. & L. Elec. Co. Daily ex Sun, 6:30-7 pm. Tues, Thurs, 9:30-10:30 pm. Sun, 1:30-2:30 pm and 6:30-7 pm. Eastern time.

WJH, Washington, D. C. White & Boyer Co. Tues, 7:30-10 pm, concert, address, lecture. Eastern time.

WJK, Toledo, O. Service Radio Equipment Co. Daily ex Sun, 3-4 pm, concert.

Mon, Wed, Fri, 7:30-9 pm, concert, lecture, etc. Sun, 7:30-9 pm, church service, concert. Eastern time.

WJT, Erie, Penna. Elec. Equipment Co. Daily ex Sun, 7:30 pm, baseball, markets, weather, police reports. Mon, Wed, Fri, 8, bedtime stories; 8:15, concert, lecture. Sun, 7:45 pm, church service. Eastern time, daylight saving.

WJZ, Newark, N. J. Westinghouse Elec. & Mfg. Co. Daily ex Sun, 15 minutes hourly from 9 am to 6 pm; 12-12:30 pm; 7-10:15 pm. Miscellaneous program of highly varied nature. Sun, 3-10:15 pm, misc. Eastern time, daylight saving.

WKC, Baltimore, Md. Jos. M. Zamoiski Co. Tues, Thurs, Sat, 7:30-8:30 pm. Eastern time, daylight saving.

WKY, Oklahoma City, Okla. Oklahoma Radio Shop. (Daily Oklahoman) Daily, 12 m. weather; 7-7:30 pm, baseball, specials; 8:30-9:30, concert; 9, weather, news. Sun, 3:30-4:30 pm, concert. Central time.

WLE, Indianapolis, Ind. Hamilton Mfg. Co. Tues, 8-8:55 pm, concert; 9-10, vaudeville, news. Thurs, 8-8:55 pm, concert, lecture, news. Sun, 8-8:55 pm, sacred concert. Central time.

WLW, Cincinnati, O. Crosley Mfg. Co. Tues, Thurs, Fri, 8 pm, concert, lecture, news. Sun, 8 pm, church service. Central time.

WME, Cincinnati, O. Precision Equipment Co. Daily ex Sun, 11 am and 4 pm, weather, markets. Mon, Wed, Sat, 8:15-10, concert, lecture, vaudeville, news. Central time.

WNO, Jersey City, N. J. Wireless Tel. Co. of Hudson Cy. Daily, 10 pm, news, concert. Eastern time.

WNJ, Albany, N. Y. Shotton Radio Mfg. Co. Mon, Wed, Sat, 8-9:30 pm, music, entertainment. Eastern time, daylight saving.

WOC, Davenport, Ia. Palmer School of Chiropractic. Daily ex Sun, 12-12:15 pm, markets, weather, concert; 3:30-4, lecture; 5:45-6 and 7-8, concert. Sat, 8-8:15, business review. Sun, 9-10 am and 5:30-6 pm, sacred concert. Central time.

WOE, Indianapolis, Ind. Hatfield Elec. Co. Daily ex Sat and Sun, 10-11 am and 4-5 pm, financial, concert. Mon, Wed, 8:30-10 pm, concert. Sat, 10-11 am and 1-2 pm, financial, music. Sun, 10-11 am, concert. Central time.

WOK, Pine Bluff, Ark. Arkansas Light and Power Co. Daily, 7:30 pm, baseball, markets, weather, news. Tues, Fri, 8-9:30 pm, concert. Sun, 11 am and 7:45 pm, church service. Central time.

WQC, Kansas City, Mo. Western Radio Co. Daily ex Sun, every half hour 9:30-1:15 pm, markets; 1:30 am, 2 pm, 7:30, markets, weather, road conditions; 7:45-9, concert, vaudeville. Sun, 7 pm, church service. Central time.

WOR, Newark, N. J. L. Bamberg & Co. Daily ex Sun, 20 minutes or half hour from 10:30 am to 6:30 pm, miscellaneous. Eastern time, daylight saving.

WOZ, Richmond, Ind. Richmond Palladium. Daily ex Sun, 12-12:15 pm, markets; 4-5, concert, news, markets; 6:30 pm, concert, news, weather, lecture. Central time.

WPA, Fort Worth, Tex. Fort Worth Record. Daily, 11:30 am, weather; 7:30 pm, baseball, concert; 9:30, news; 9:50, weather. Central time.

WPE, Kansas City, Mo. Central Radio Co. Mon, Fri, Sun, 7:45 pm, concert. Sun, 8:15 pm, sermonette. Daily, afternoon, baseball scores. Central time.

WPM, Washington, D. C. Thos. J. Williams, Inc. (Washington Daily News). Daily ex Sun, 12:30 pm, news. Mon, 8 pm, concert. Eastern time.

WPO, Memphis, Tenn. United Equipment Co. (News-Scimitar). Daily, 7-9 pm, concert, news. Central time.

WRK, Hamilton, O. Doron Bros. Elec. Co. Mon, Wed, Sat, 8:30-10:30 pm, concert, news. Fri, 7:30-9:30, concert. Sun, 10:45 am and 7:30 pm, church service. Central time.

WRL, Schenectady, N. Y. Union College. Sun, 7:30 pm, sacred concert, speeches,

etc. Irregular miscellaneous weekday program. Eastern time.

WRM, Urbana, Ill. Univ. of Ill. Thurs, 8:30-8:55 pm, 9:05 on, news, concert, lecture. Special concerts irregular. Central time.

WRR, Dallas, Tex. City of Dallas. Daily, 7 pm, police news, sports, weather; 8:30-9:30, concert. Sun, 11 am and 7:30 pm, church service. Central time.

WRW, Tarrytown, N. Y. Tarrytown Radio Research Lab. Tues, Thurs, Sat, 10:05 pm. Sun, 10:30 am, 2 pm, 10:05. Eastern time, daylight saving.

WSE, Atlanta, Ga. Atlanta Journal. Daily ex Sun, 12 m, weather; 2:30 pm, markets; 4, concert; 5, baseball, news, bedtime story; 7-8, concert. Sun, 11 am and 5 pm, church service. Central time.

WWJ, Detroit, Mich. Detroit News. Daily ex Sun, 9:30-10:30 am, hints to housewives, concert, weather; 10:55, time signals; 12:05-12:45 pm, concert; 3:30-4:15, markets, weather; 5-6, news, baseball. Week of May 28 and every other week, 7-8 pm, concert, lecture. Fill in weeks, 8:30-10 pm, concert, lecture. Sun, May 28 wk etc., 9:30 am-2:30 pm, church services and special; 4-6 pm, special. Sun, fill in wks, 2-4 pm, special; 6-10, church services and special. Eastern time.

WWX, Washington, D. C. Post Office Dept. Daily ex Sun, 10 am, weather; 10:30, markets; 5 pm, 7:30, 8, markets; 9:50, weather. Eastern time.

WWZ, New York, N. Y. John Wanamaker. Daily ex Sun, 1:40-2 pm, 2:40-3, 3:40-4, 4:40-5, 10:30-12 midnight, concert. Eastern time.

WYN, Washington, D. C. Nat'l Radio Inst. Daily, 6:30-7:30 pm, instruction. Eastern time.

WBU, Louisville, Ky. Darrell A. Doward. Mon, Wed, 8 pm, police news, concert. Central time.

WVD, Denver, Colo. W. D. Pyle. Sat, 8-9:30 pm, concert. Sun, 5:30-7:00 concert. Mountain time.

WYY, Lincoln, Nebr. Univ. of Nebr. Daily ex Sun, 10:10 am, stock and grain markets, weather; 7:30 pm (irregular), concert. Central time.

"ALL-AMERICAN" RADIO APPARATUS
 Audio and Radio Frequency Amplifying Transformers
RAULAND MANUFACTURING CO., CHICAGO
 AT LEADING DEALERS OVER THE COUNTRY

LIGHTNING PROTECTIO

N With S & C Arrester
Schweitzer & Conrad, Inc.
 4439 Ravenswood Avenue, CHICAGO

A Better Variometer

ESTRU LATTICE VARIOMETERS AND VARIOCOUPERS are small compact instruments with no unnecessary frame work, which makes them most easily wired.

MAXIMUM EFFICIENCY by lumped inductance and low distributed capacity. **SHARP TUNING.** Ideal for portable sets and for those who assemble their own, because of easy accessibility.

IMMEDIATE DELIVERY

VARIOMETER . . . \$5.00
 VARIOCOUPLER . . . \$4.50

Mail orders promptly filled

DEALERS: Write for Our Proposition

NORTHERN RADIO SUPPLY CORP

COMPLETE SETS. COMPLETE LINE OF APPARATUS

542 West Washington Street Phones Main 2230-2231 CHIC

Radio Digest Illustrated

TRADE-MARK

E. C. RAYNER, Publisher
123 WEST MADISON STREET
TELEPHONE STATE 4844-4845
CHICAGO, ILLINOIS

New York Office - - - - - 2126 Broadway
Detroit Office - - - - - 28 Rowland Building

58
PUBLISHED WEEKLY

SUBSCRIPTION RATES
Yearly.....\$5.00 | Foreign.....\$6.00
Single Copies, 10 Cents

Entered as second-class matter April 27, 1922, at the post office at Chicago, Illinois, under the Act of March 3, 1879.

In a new scientific field where many writers are contributing articles there will arise some controversy over the expressions of opinions and statements made from time to time. Some of these controversies may be taken into the courts for settlement. The priority of inventions may be claimed as well as the merits of some part entering into the construction of the radio apparatus. The Radio Digest is an outlet for these expressions and the publisher disclaims any responsibility for opinions or statements made in connection with radio apparatus. The news will be printed as it comes to us.

Vol. 1 Chicago, Saturday, May 27, 1922 No. 7

One of the Seven Modern Wonders

The Radiophone Tops the List

THE wonders of the ancient world numbered seven. If you had hunted diligently at that time you could not have found more if you tried. In recent years a magazine tried to dig up seven modern wonders and the best talented men here and abroad were consulted. A thousand were interviewed and the consensus of opinion resulted in placing Radio at the top of the list.

We are living in a wonderful period of time. A time when things are going at a break neck speed. One person sets a new idea, that idea travels fast, it is linked with another person's idea a thousand miles and the combination results in a big venture. Radiophone within itself is a sender of ideas—messages—from one inventor to another. It was difficult to start at first, just like a baby learning to talk, but when learned the speed soon reaches the limit of the known devices of today.

Will Radiophone Chase Out Jazz?

Will Enthusiasm for Radio Lift Youth to Higher Levels?

WE WONDER if the deep interest taken in Radio will be a cure for jazz. We hope so. The youth of today seems to have shot off at an angle, and in their recklessness they have brought about the hysteria of jazz music, jazz philosophy, characterized by fatalism, indifference and immorality. We shall be glad to see the passing of the jazz with its weird, discordant sounds, and the passing be so good that it will find no place in the future of America. Its going will be hastened as young America is turning from the frivolous to more serious thought.

Radio and Wire Phones Not Alike

They Are So Different That They Do Not Conflict

AFTER considerable study the telephone engineers have come to the conclusion that Radio and wire telephony have entirely different fields and functions which do not conflict.

The natural characteristics of Radio and wire transmission are fundamentally different. One of these systems performed a duty for which the other is unsuited, and each is supplementing the other to the end that all important needs for communication are being provided for as rapidly as they arise.

The use of wires is necessary for handling the large amounts of traffic on land, which must be done with certainty and minimum of cost. We can plainly see where Radio will render a service of the greatest value for communication over wide stretches of water, with moving conveyances generally, for a host of maritime military purposes and for the broadcasting of news. It would appear that these fields mentioned in which the Radiophone will be of greater value.

It has often been said, that, had the course of scientific development been reversed so that Radio transmission by wire, the discovery of which would be used to guide the ether waves would be one of the marvels of science. By their use uncontrolled ether waves are caused to travel along predetermined pathways, flashing thousands of miles up through the intricate structure of office building, or out across the sky and over mountains, to the far side of the globe to be received by him—and him as intended.

Fad Is Not the Proper Name

An Industry Represented by Millions Is Not a Fad

A GREAT many of us not knowing the possibilities of the Radiophone are apt to label it as a fad. Fad is not the proper name for this fast expanding industry. Most of us are inclined to speak of a thing as a fad just because it is going too fast for us. If we do not swing into line with others and do not get the thrill of the moment, then we become sour and say "fad." Almost as great things as Radiophones have "gone over," yet they were called fads. Perhaps the speed of the Radiophone is astounding but we must remember there are a few more of us on this globe now than there were when the bicycle and phonograph had their plunge. The Herald (Hamondsport, N. Y.) has a nice article on this subject, which reads:

"Possibly never before has anything spread over this country as rapidly as the 'Radio' craze, with which papers and magazines, big and little, are now filled. At first glance people are apt to mistake this talk as merely a passing fad. But our advice to them is not to do so. If the boy is interested and wants to learn more about Radio, give him the opportunity. Too many successful experiments have already been made with the Radio system of telegraphy and Radiophony to put it into the fad class. Today messages are being broadcasted into every section of this land without the use of wires, just as they have for years been sent for hundreds of miles across the water from one ship to another, and from ships to stations on the land. Of course, Radiophones have not been perfected. It took years to perfect the steam engine, the automobile and the airplane, and place them beyond the experimental stage. But today they are practical, and we would find it mighty dull living in this land if we did not have them."

Those of you who desire to call the Radiophone a fad just buy, beg or borrow a receiving set and listen in for awhile. It will not take any of the waves away and none of us will notice that you are listening in. You can hide in your closet, if you desire, nobody will know it and you can get the messages there just as well. It will do you good and later you will not be so narrow minded. The Globe (New York) has a little to say about fad in these words:

"Is Radio a passing fad? The moving picture had its fad days. The phonograph had its fad days. Both survived them; both won the lasting approval of the public. The telephone was once a luxury. Tomorrow it will be a necessity. We are witnessing the sunrise of a new American institution. Radio is here to stay. Radio is not only a form of entertainment. It has just started to demonstrate its utilitarian value. We must not lose sight of its educational possibilities. Radio is adrift in a boundless sea of opportunity. That it will eventually affect our social and political life there can be no possible doubt. Let us not cry 'fad' before we give the matter due consideration."

Most of us enter a new proposition with too much enthusiasm and we do not stop to think that it is not free from complications. It is so with the Radiophone. Many of us will drop out, possibly, just because the receiving outfit did not come up to our expectations. No effort will be made to find existing troubles that are bound to come along with such a new device. There will be a great deal of experimenting with every outfit, for, being in the development stage, Radiophones offer much room for improvement. The Star (Washington, D. C.) expresses its opinion in these words:

"It is gripping, to say the least, when for the first time a headphone is adjusted and music is heard, apparently coming from nowhere. There may be something almost uncanny in hearing a human's voice speaking or singing, clearer than over the telephone, and knowing that the possessor of the voice is twenty or a thousand miles away and that his message, first caught in a few strands of wire, is then transferred to the ears by the juggling of coils of the same kind of wire."

"Radiophony and the broadcasting of the human voice and music by Radio apparatus is a comparatively recent innovation in an age replete with marvels of electrical application. It is not a recent invention, but rather a gradual perfection that has been going on for the past ten years or more. Today it is still in the process of development, but has reached the stage where expansion and application will be very rapid. Its possibilities from now on are limited only by the rapidity with which acceptance by the public is gained."

"The development of the Radiophone has now passed the fad state, and, while it is not yet a necessity, it is in the intermediate period, where it is being taken into the homes of all classes of people. Its greatest expansion and usefulness is yet to come. It will have a great growth and become as much a necessity as the telephone."

The following is the way the Tribune (Minneapolis) speaks of the Radio fad:

"Few people get the real significance of America's enthusiasm for the Radiophone," said a Radiophone fan the other day. "With many it may be only a fad or a plaything, but the amazing growth of receiving stations is a big factor in our national life. America is stealing a long march on the rest of the world in multiplying these stations and she will hold this lead and profit by it."

RADIO INDI-GEST

The Story of the Lost Golf Ball

Radio, Radio, whither thou go
They use you everywhere,
North, South, East, Westward ho;
You flash thru space and air.
In Churches, Clubs, Theatres, too,
Nothing stops you, always there—
What is it "you can't" do?



Scientists can control airplanes
Boats, cars and things with you,
Soon they will control the rains,
Even the Spirits harken to you;
You certainly have gained fame,
But, Radio, can you, after all,
Find a little "lost golf ball"?

Radioitis

By J. Dwight Bunce

The News has got us going,
We've got the Radio bug;
From millionaire to pauper
It's called us on the rug.

It's not a bad affliction,
The little Radio germ;
And the funny part of all is
We hate to wait our turn.

At stores now where we get them,
You'll find us lined ten deep;
Not happy till we get it
To lull us off to sleep.

There's many kinds of outfits
With just as many names—
Swearing, "simple operation"
If you've got normal brains."

I for one am smitten,
For I listened in and heard
The voice of Emma Calve
Singing like a bird.

Uncanny? Well, I'll say so—
Most ghostly in its way,
Invisible and flies in air;
Naught stops its tuneful play.

Now The News has made it possible
For all of us to hear
A concert of the better sort,
Each day of every year.

I think a vote of thanks you need
From each and every one.
I'm sure a million're with me
From morn till setting sun.

And when the family listens in
The dinner dishes cleared away—
We're all prepared for what will be
The end of a glorious day!

—[Detroit News.

WILLIE JONES HAS A LOT OF TROUBLE
KEEPING THE BIRDS OFF HIS ANTENNA.



Nothing to Prevent It If Your Hearing Is Good

I have just bought a wireless receiving set and I would like to know if I can receive music, speeches, concerts, etc.

ANSWERED

If your hearing is good and the instruments are connected to a ground and aerial, I don't see what's to prevent you.

Radio Telephony for Amateurs and Beginners

Radio Transmitting Stations

By Peter J. M. Clute

Part II

In Radio systems, alternating currents of extremely high frequency are commonly used; anywhere between 10,000 to 2,000,000 or more cycles per second. These frequencies are called Radio fre-

quencies; lower frequencies are also sometimes used in certain classes of Radio work.

The frequency of an alternating current is the number of cycles that it passes through in one second. An alternation is half a cycle—there are two alternations in a cycle, one in the positive direction and the other in the negative direction.

An alternating current is one which constantly changes in direction; in other words, one which increases and decreases in strength periodically, first in one direction and then in the opposite. Due to the fact that an alternating current changes in direction and in intensity at regular intervals, certain effects become of importance. These are the effects of "inductance" and of "electrostatic capacity."

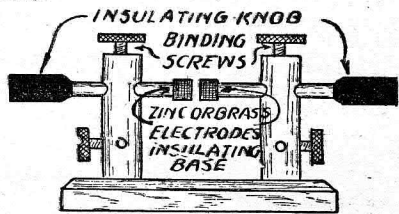

STATIONARY SPARK GAP
FIG. 2

Whenever a change occurs in the magnetic field linking with a conductor, there is induced in the conductor an electromotive force, equal and opposite to the electromotive force which would have to be applied to a conductor to produce the same change in the magnetic field. The change in magnetic field is produced by a variation in the current flowing in the circuit, and the inductance, or self-inductance, of a circuit is defined as the ratio between the E. M. F. induced and the rate at which the current changes in value. In the practical system, a circuit has unit inductance, namely, one henry, when an E. M. F. of one volt is required to produce a change in current at the rate of one ampere per second.

A system of conductors insulated from

the choice of apparatus, its design and the circuit in which it is connected has been largely influenced by the whims of

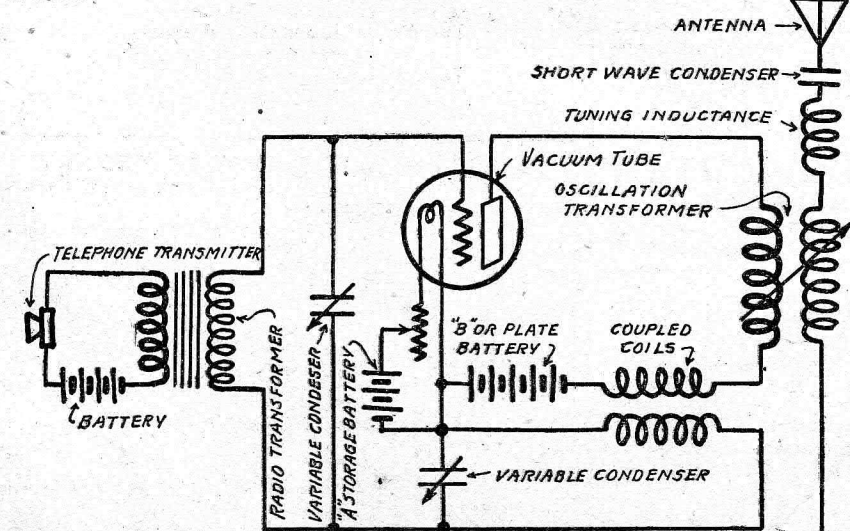

Figure 3

VACUUM TUBE AS A RADIO TELEPHONE TRANSMITTER

one another and so capable of holding charges and of maintaining a field between the conducting surfaces, is called a "condenser." The unit of capacity is that of a condenser, in which a unit charging current will be maintained by increasing

the designer. There are a large number of circuit arrangements all about equally good, but frequently unnecessarily complicated. A simple circuit, sufficient for purposes of explanation, is illustrated in Fig. 1. In this circuit, close approximation to

the ideal case is obtained, in which the secondary circuit is excited through the discharge of a condenser in the primary circuit. It is customary to use a separate tuned circuit for the spark gap and to couple that circuit with the antenna circuit, as shown in the illustration. The coils used in coupling the circuits are frequently termed an "oscillation transformer."

The circuit of the transmitter, containing the condenser, the spark gap and the primary winding of the oscillation transformer, is designated as the closed oscillatory circuit, as distinguished from the open, or radiating circuit which includes the antenna, the aerial tuning inductance, the short-wave condenser and the secondary of the oscillation transformer.

A charging circuit is supplied to the condenser through an inductance. The spark gap, a simple form of which is shown in Fig. 2, maintains the closed circuit at rest until the condenser is fully charged. The charging current is quite small but the discharge current when the gap breaks down may be many times as great. This discharge of the condenser across the spark gap, sets up high frequency oscillations in the closed circuit, which induce oscillations in the open radiating circuit. The spark gap should then quench the oscillations of the closed circuit, leaving the antenna circuit free to oscillate and to send out the energy of

secondary is so constructed that it may be moved toward or away from the primary in variometer fashion, thus permitting almost any degree of coupling. "Close" coupling is obtained when the windings are in close proximity to each other; when the windings are separated, the coupling is said to be "loose." The antenna tuning inductance is used to increase the length of the Radio waves

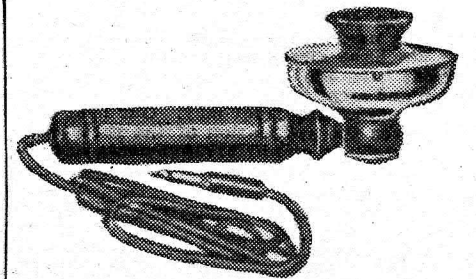

Figure 4

sent out from the antenna, above the natural wave-length of the open, or antenna, circuit.

In wireless telephony, a continuously-transmitted high frequency is modulated by the voice frequency. This is effected by causing the currents in a telephone transmitter circuit to affect the high-frequency currents as they are being produced. Fig. 3 shows how the current in a telephone transmitter circuit may be impressed on a vacuum-tube generator. There is impressed upon the tube two voltages, one a continuous high frequency, and the other a low or audio-frequency. The output of the tube comprises two high frequencies. The tube also acts as an amplifier or repeater and so transmits directly the high-frequency oscillations. At the receiving station, then, the current in the detector would comprise components, having frequencies of the sum and the difference of those it receives, thus producing in its output circuit a frequency which is the frequency of the speech input at the transmitting station.

In principle, the Radio telephone is quite similar to the telegraph. In its strong continuous waves, called "carriers," are set up by the transmitter circuit, as long as no one speaks in the transmitter or microphone, the waves are smooth and inaudible in ordinary receivers, inasmuch as their frequency of vibration is above the limit of audibility. When someone speaks, the audion, or vacuum tube impresses the current variations from the telephone transmitter circuit upon the high-frequency carrier wave. The receiving detector catches the carrier wave and with its superimposed low-frequency waves and rectify them into audi-frequency waves which duplicate the speech in the telephone receiver.

The representative radiophone broadcasting station consists of a studio, an apparatus room and a transmitter room. In the studio, there will be found a number of portable microphones, commonly called "pick-up" devices, which can be shifted about to locations best suited for the reception of musical selections, announcements, lectures, etc. For announcing a

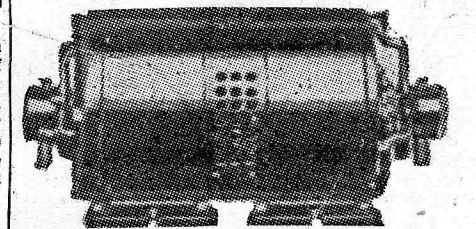

Figure 5

hand transmitter such as is illustrated in Fig. 4 is often used.

In the apparatus room, the sound waves undergo several steps of amplification through the medium of vacuum tubes. The amplified waves, which are now electromagnetic in character, have been increased thousands of times in volume and pass on through another bank of vacuum tubes which modulate the electric waves.

High-voltage direct current is used for operation of a transmitting station. For low-power stations, this may be from a high-voltage motor-generator, as shown in Fig. 5. For larger low-voltage alternating current is up by a transformer. This voltage passes through vacuum tubes which change it to direct-current entering a high-power oscillator placed between the rectifier and the electromotive waves through the modulator to the antenna circuit to be transmitted.

Practically all of the development in voice transmission is due to the work of the vacuum tube. This will be described in a

Peter J. M. Clute—

FOR several years has contributed technical articles to various periodicals and is well known in electrical engineering circles. A graduate of Union college with a degree of Bachelor of Science in Electrical Engineering, Mr. Clute is now connected with the engineering department of the General Electric company.

Realizing the importance of giving the new Radio fans a comprehensive knowledge of electrical fundamentals necessary to secure a reasonable understanding of Radio, Mr. Clute has prepared a series of articles especially adapted to the novice.

The articles to be published in the RADIO DIGEST in ensuing numbers include:

- III. THE AERIAL AND THE GROUND.
- IV. CONDENSERS.
- V. TUNERS AND TUNING.
- VI. DETECTORS: CRYSTAL AND VACUUM TUBE
- V. THE BATTERIES.
- VI. RECEIVERS AND LOUD SPEAKERS
- VII. CRYSTAL DETECTOR RECEIVING SETS.
- VII. VACUUM TUBE RECEIVING SETS
- VIII. AMPLIFIERS.
- IX. USEFUL INFORMATION.

Characteristics of Vacuum Tube Amplifiers

By Benjamin F. Miessner

Part V

Use of Three Electrode Tube in Radio Circuit

In our previous installments we have studied the most important operating characteristics of vacuum tubes and have analyzed these characteristics with reference specifically to use for rectification and amplification of weak alternating or impulsive currents. We now have a thorough understanding of these necessary fundamentals and we are prepared to apply this knowledge to various types of circuit arrangements used in Radio reception apparatus. We have already studied the two electrode tube and its properties for rectification and amplitude limitation of alternating currents of any frequency. Our next step involves the application of the three electrode tube to circuit arrangements and apparatus for rectification of weak high frequency currents.

Experimental Circuit Employed

In Figure 14 we have shown a conventional two circuit receiver connected with a vacuum tube detector, batteries and telephones. We will not discuss in detail the arrangements for absorption, selection, and amplification of the electromagnetic waves by electrical resonance in the receiving circuits, but will assume such arrangements in operation and impressing high frequency alternating potentials between the filamentary cathode and the grid of the

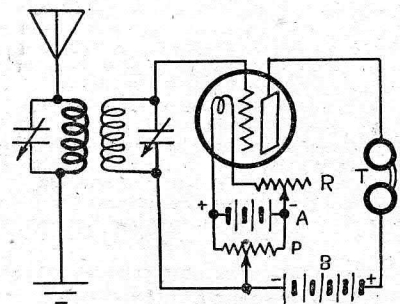

Figure 14

vacuum tube. The filamentary cathode is heated by current from the low voltage battery (A), and the plate is maintained at a uniform positive potential by the high voltage battery (B), through the telephones (T). By means of the potentiometer (P), we are enabled to maintain a steady potential on the grid for selection of the operating point on the characteristic curve.

Operation Based on Curve

In Figure 15 we reproduce again a characteristic curve of a three electrode tube to make clear the operation of the circuit shown in Figure 14. Since the current controlling resistance (R) is inserted on the negative side of the A battery circuit with the filament, it is obvious that a negative potential lower than that existing on the negative filament terminal may be obtained. We remember from our previous studies that it is better to use the lower rectifying bend (A) rather than the upper bend (B) for two reasons; first, because on bend A the plate current is comparatively low so that the drain on the B battery is

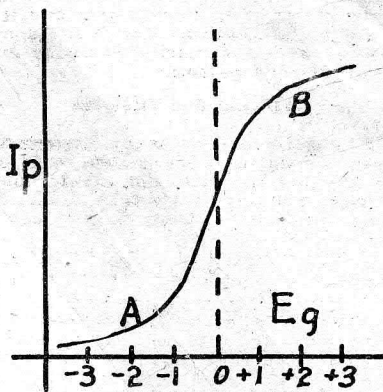

Figure 15

greatly reduced; and second, because the grid is in the region of negative potential wherein it cannot draw an electron from the Radio circuit potentials upon it. So because at no time, except for weak signals, does the grid become positive, no electron current can therefore be drawn in the grid circuit. The real reason for these facts lies in the ability to control the plate current without giving any energy from the filament. The result that the dampening in the Radio circuits is at a minimum, their potential is built up by resonance, and frequency selection of the circuit is in the final anal-

ysis this provides higher sensitivity and greater freedom from interference than is possible when the tube is operating on the upper rectifying bend.

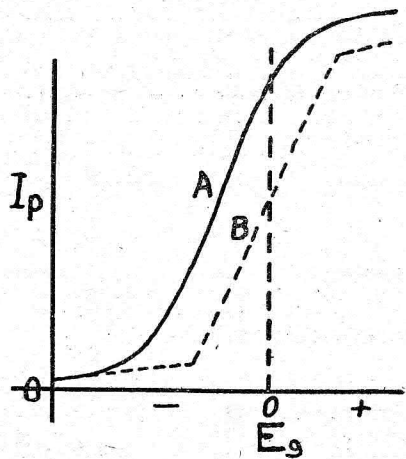

Figure 16

You will remember that the best rectification with the two electrode tube was obtained at some point on the rectifying end where a given small alternating potential produced the greatest change in plate current. The same principal holds true with the three electrode tube and for the same reasons.

Rectification Impossible for Weak Signals

It will be understood in a general way that in order to obtain any rectifying action at all, the oscillating potentials applied between grid and filament must be sufficiently large to cause a greater change in plate current for one half of an oscillation than for the other, for if the plate current decreases for the negative half of an applied cycle as much as it increases for the positive half, then the cycle will be reproduced in the plate circuit without rectification and superposed on the normal steady unidirectional plate current.

The sensitivity of rectifying devices therefore, is limited by their electrical operating characteristics. Obviously a tube with a short rectifying bend will rectify weaker currents and therefore be more sensitive than one with a relatively long bend. This is shown in Figure 16.

Comparison of Tube Rectifying Curves

Curve A has a long bend and requires a strong signal for rectification; Curve B has in comparison a short, sharp bend and will rectify very weak signals. It is evident that the two tubes with these respective curves would possess vastly different rectifying sensitivities, while their amplifying powers, as indicated by the equally steep middle portions, would be about the same.

The importance of Radio frequency amplifiers in increasing the potentials of very weak signals up to a point where they can be rectified are now fully evident. Audio frequency amplifiers can amplify only what the rectifier will rectify, regardless of their amplifying power.

The manner in which such a three electrode rectifier reproduces the wave form of a voice modulated continuous wave is somewhat similar in principle and operation to that of the two electrode rectifier. Of course the energy available for actuating the telephone in the former is supplied by the B battery, while in the latter it is supplied by the Radio signals themselves.

Graphics of What Takes Place

In Figure 17 are shown by the various graphs the nature of the phenomena occurring in such a rectifying circuit with respect to potential and current in the various parts. In A is shown a train of continuous unmodulated waves of potential of amplitude E about the zero axis of time, set up across the terminals of the secondary tuned circuit shown in Figure 14.

In B the straight line below the zero potential axis represents the normal steady negative potential impressed on the grid of the rectifying tube by the A battery, and regulated by the potentiometer, through the conductive winding of the secondary inductance coil of the loose coupler shown schematically in the drawing.

In C is shown the Radio frequency potential wave train of graph A superposed on the steady negative potential of graph B, and graph C represents the actual potential variations with time on the grid with respect to the negative end of the filament.

In graph D is shown by the straight line parallel to the time axis the steady plate current through the tube, telephones and "B" battery of an amplitude determined by tube and circuit constants at the rectifying point selected by the operating grid potential.

In graph E is shown the variations in the plate current under the action of the grid potentials shown in graph C, with the telephones in the plate circuit removed to permit the Radio frequency wave form to develop without smoothing out. It is seen that positive alternations of the signal

potential of A cause a much greater increase in plate current above the dotted line (representing the normal, plate current), than the decrease produced by the

the separate pulses of Radio frequency are smoothed out by the high inductance of the telephone windings so as to produce a steady current during the continuance

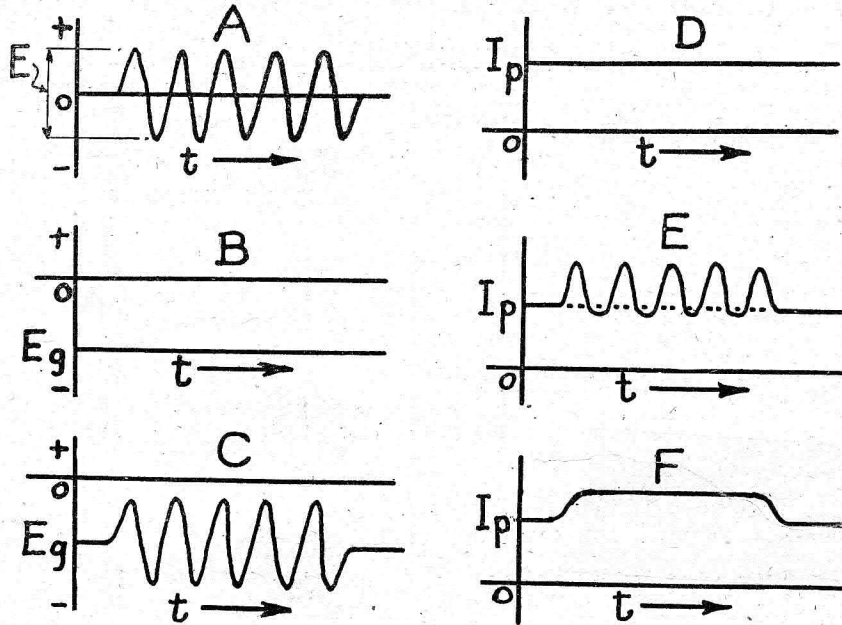

Figure 17

negative alternations, so that the average plate current is increased during the time that the Radio frequency potentials are applied to the grid circuit.

Graph F shows the actual nature of the plate current change with the telephones present in the circuit. This shows that

of the applied Radio frequent electromotive force.

Editor's Note—Mr. Miessner will discuss rectifier distortions and amplifier theory in the next installment of his authoritative series. Due to his great activity in Radio research, the divisions of the subject must continue at irregular intervals.

Radio Boomerang

The girth of the world is now one-tenth of a second, the time required for a Radio wave to make the circuit. It may soon be possible for an operator to speak as Columbus sailed, into the West and hear his own voice from the East.

Heathens Get Gospel by Radio

Missionaries will have an easy trail to travel in the future if Radiophones are to be used in the spreading of the gospel. Radio broadcasting as an aid to the dissemination of the gospel is now being considered by missionary bodies.

"Why Use an Antenna?"

THE SUPER-ANTENNA NOW AVAILABLE

This unit is the original design developed by the country's foremost engineers for radio reception over the electric lighting circuits. Outside antenna is unnecessary.

This unit does away with the dangers of stringing antenna over power and lighting wires, where great danger results when storms or other causes result in the antenna touching a live wire. The "Super-Antenna" also eliminates the troubles and dangers incident to the erection of the antenna.

The "Super-Antenna" is shock proof, will not blow fuses, and will not damage a receiving set in any way. Imitators will probably attempt to duplicate this epoch-making invention, but during the many months of development of this unit all practical circuits were protected, and it will prove expensive to experiment with imitations.

OPERATES ON ANY ELECTRICAL CIRCUIT

No power current is used when operating with a "Super-Antenna." It operates on any electrical circuits from 32 to 120 volts, D. C. or A. C. The light plug can be turned either "ON" or "OFF."

In the majority of circuits the "Super-Antenna" tends to reduce static effects.

The unit functions similar to the ordinary antenna, and where the electric-lighting wire runs aerially into the building, exceptional results have been obtained. However, in congested districts in down-town sections, where steel construction buildings dominate, the shielding effect of this metal, and of grounded conduit, of course affects the "Super-Antenna" the same as it will any aerial. However, in down-town districts for local broadcasting receiving, the "Super-Antenna" gives marvelous results. Stations twelve hundred miles distant may be readily copied with the ordinary installation, depending, of course, on the power of the transmitting station and the sensitivity of the receiver used.

Where no series condenser is in the antenna circuit of the receiving unit, best results are obtained by inserting a condenser of about .0005 mids. in series between the binding post of the "Super-Antenna" and the post marked "Antenna" on the receiving set.

In installation of the "Super-Antenna," no safety gap for lightning protection is necessary.

Orders Filled in Order of Receipt

COMPLETE
ONLY
\$7.50
Parcel Post
\$7.75 West of
Rockies
\$8.75 Canada



Special
Proposition
to
Dealers
Write
or
Wire

SUPER-ANTENNA COMPANY
QUINCY, ILLINOIS, U. S. A.
Sole Distributors

Simple Instructions for the Beginner

By Harry J. Marx

The Use of Telephone Jacks and Plugs

The use of telephone jacks for Radio receiving sets has now become standard practice and it is quite obvious that the amateur not only wants to become acquainted with the advantages but also wants to install them in his own sets. They provide a convenient and rapid means of shifting the receivers from one stage to another. They can be connected so as to cause the insertion of the plug in any stage to light only those filaments required by that stage of amplification. Removal of the telephone plug immediately can extinguish all filaments and permit their re-lighting by the mere insertion of the plug without adjustment of the filament rheostats. Because of the completely automatic lighting and extinguishing of the filaments, through the use of proper filament control jacks, the useful life of the vacuum tubes is greatly increased and the drain on the filament batteries is reduced to a minimum.

In Figure 1 five different types of telephone jacks are illustrated, both in the photograph of the commercial products and also in the conventional form it is represented in the wiring diagrams and hook-ups. To the man acquainted with telephone circuits they present no difficulty in interpretation but the amateur often finds it difficult to follow the circuit through the jacks. Before explaining the operation of the jacks, it would be well to look at Figure 2, showing the cross-section of the typical telephone plug. It will be noticed that we have two distinct connections that are made through the plug. One through the sleeve of the plug has a connection to the terminal inside the rubber body, the other terminal is connected to the tip by means of the rod running through the center of the plug. The receivers are connected to the two terminals in the body of the plug and the connections to the jack are made through the tip and the sleeve.

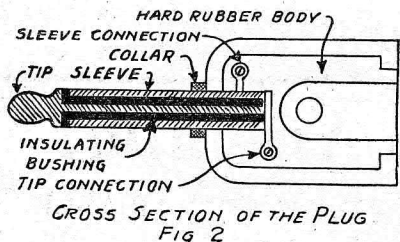

Description of the Jacks

Jack "A" in Figure 1 is the simplest form made. When the plug is inserted the tip presses against the spring contact, while the sleeve makes contact with the body of the jack. In this way we are

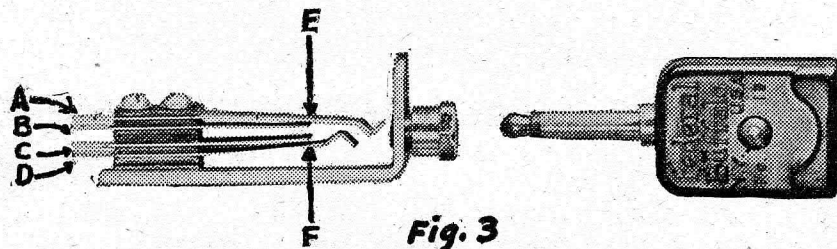

able to connect and disconnect the receivers as desired. The use of jack of this type with a crystal detector set is shown in Figure 5. Jack "B" is somewhat similar to the previous case, but here we have an additional spring that makes a contact with the first spring when the plug is out, but when the plug is inserted in it the tip makes contact with the first spring, and in pressing it back, breaks the contact with the second spring. This jack can be used in plugging into different stages of amplification, but will not operate as a filament control jack. In the convention this additional contact is represented by the arrowhead as being in contact with the top spring. This indicates that when the plug is inserted the contact is broken. Jack "C" has two springs for making contact with the tip and sleeve of the plug. The body of the jack is not used for a connection in this case. In addition there are two additional springs making contact with the first two when the plug is out. When the plug is inserted these two contacts are broken. Figure 3 shows the plug and jack. Springs A and B make contact at point E, while springs C and D make contact at point F. Figure 4 shows the plug inserted in the jack. Spring A no longer makes contact with spring B, but now makes contact with the sleeve of the plug. The contact between C and D is broken, and D makes contact with the tip of the plug. It will be noticed that the springs are separated by pieces of insulating fibre, preventing any short circuits be-

tween the springs. The ends of the springs project and terminate in hooks to which the connecting wires are soldered.

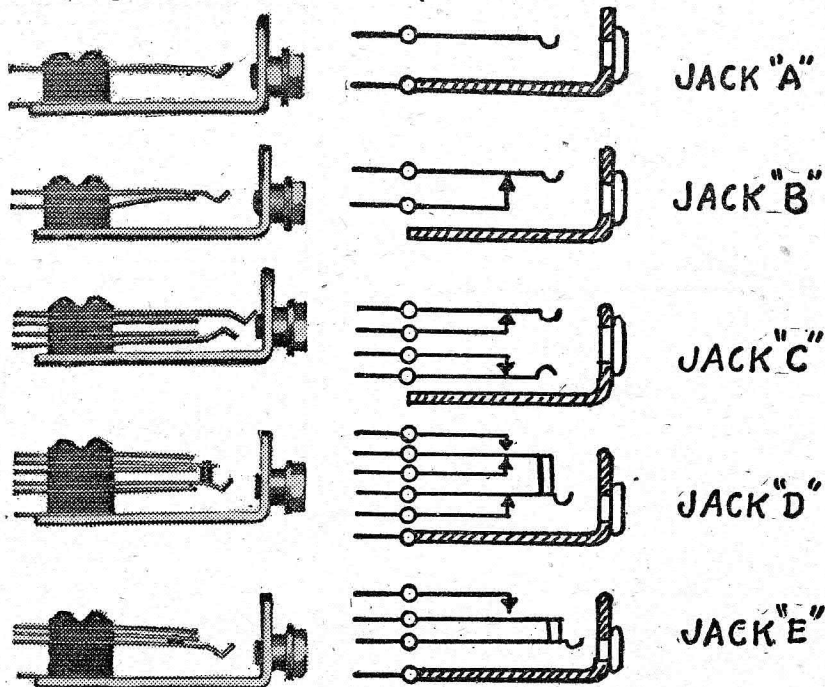

FIG. 1

Filament Control Jacks

So far the jacks have had a limited use, and have been easy to understand. For filament control in addition to connecting the receivers, we need a more complex type of jack. The most used of this type is shown as jack "D." It will be noticed that in this type the sleeve of the plug makes contact with the body of the jack while the tip breaks contact with another spring as before when the plug is inserted. In addition, this spring is connected to another spring by means of an insulated spacer, so that this new spring moves with the first, but is not electrically connected to it. This third spring touches another spring when the plug is out, but when the plug is inserted it breaks contact and makes new contact with a fifth spring above. In using this jack, the three lower terminals to the body of the jack and the two springs are used for the receiver connection, while the three upper terminals of the three independent springs are used

spring makes contact with the tip as before, but we do not have the other spring for breaking contact. In the same way the insulated spring working with the tip spring makes contact with the one above when the plug is inserted, but does not break contact with another as before.

Using the Filament Control Jacks

Figure 6 is the hook-up diagram for a three stage audio frequency amplifier with detector using filament control jacks. For the detector and first and second stages of amplification type "D" jacks are used, but

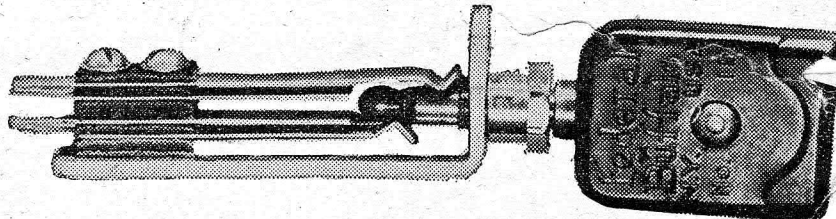

for the last stage of amplification the type "E" jack is used. First it will be noticed that the one side of the filament of all four tubes is connected to the positive terminal of the "A" battery, the other side of the filament after passing through the filament rheostat goes to the second spring of its respective jack. The top springs of all the jacks are connected to the negative terminal of the "A" battery. Therefore, when the plug is inserted in any jack it lights that filament, but the third spring in the detector jack is connected to the second spring in the 1st Amp. jack, the second spring in the 2nd Amp. jack, and the third spring in the 2nd Amp. jack to the second spring in the 3rd Amp. jack. Therefore, when the plug is inserted in the 1st Amp. jack, for example the first and second springs make contact and the filament of the 1st amplifying tube is lighted, and because of the connection to the third spring of the detector jack which makes contact with the second spring of the detector jack, the filament of the detector

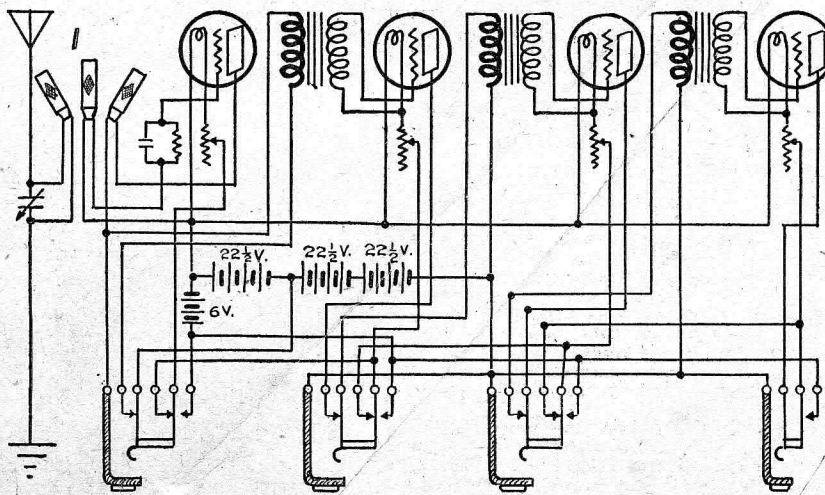

tube is lighted also. In inserting the plug in the 1st Amp. jack the contact between the second and third springs is broken so no current will be fed to the 2nd and 3rd stage tubes. This same is true for all the other stages.

In the 1st, 2nd, and 3rd Amp. jacks the insertion of the plug connects the receiver between the plate and the positive terminals of the "B" battery, in the 1st and 2nd it simultaneously breaks the contact to the primary winding of the transformer of the following stage which is connected to the fifth spring of the jack of the preceding stage.

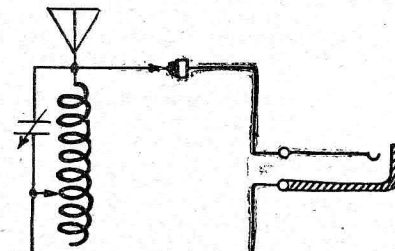

In the detector jack the plug connects the receivers between the tickler coil and the battery, at the same time breaking the contact to the primary of the transformer of the 1st stage of amplification.

It is quite distinctly shown that the jacks clearly break the circuits between the stages not in use and those that are in operation. Failure to do this would seriously affect the efficiency of the set.

The ingenuity of the amateur will suggest many ways of making use of telephone jacks in his receiving sets.

Selling Regenerative Receivers

(218) LTC
Please find enclosed stamped and addressed envelope for reply. Will you

please tell me where I can send my burned out VT to have new filament put in. Also would I be infringing on any patents by making two Variometers and one Vario Coupler regenerative receiver and selling same? If so, from whom could I get permission.

A.—1. We know of no company recharging burned out tubes.

2. You may make for your own use but not sell, legally, any receiving set employing the Armstrong regenerative circuit or ramifications of same. The Westinghouse Electric & Manufacturing Company owns the Armstrong patents.

Burning Out Filament

(221) JCN
If I equip both sides of my filament with fuses now on the market made to fit over the parts of the tube, and should happen to short 110 volt, 60 Cycle A. C. through same, would it be likely to burn out the tube or blow the fuses?

A.—The chances are that you would burn out the tube.

Where to get a E. & S. Gauge

(331) HW
Please inform me what size wire is used in the secondary of a Ford spark coil? Also where I may obtain a E. and S. wire gauge.

A.—1. We have no idea of the size of wire.

2. Write to Brown & Sharpe, Providence, R. I. Any hardware store should handle E. and S. gauges.

Boosting Signals In Telepho

(271) STN
In your last issue of RADIO Vol. 1, number 3, on page 14, a hook up (RD-2) over the capturing the Crystal Set With a F should like to have more effects produced by hooking this manner. It is not clear "boosting" you mean increase of the set, increasing the waves and increasing the produced by the receiving like to know which is right.

A.—By connecting a crystal set the signals greatly strengthened.

No. 7

Radio Digest Illustrated

By: Harry C. Marx

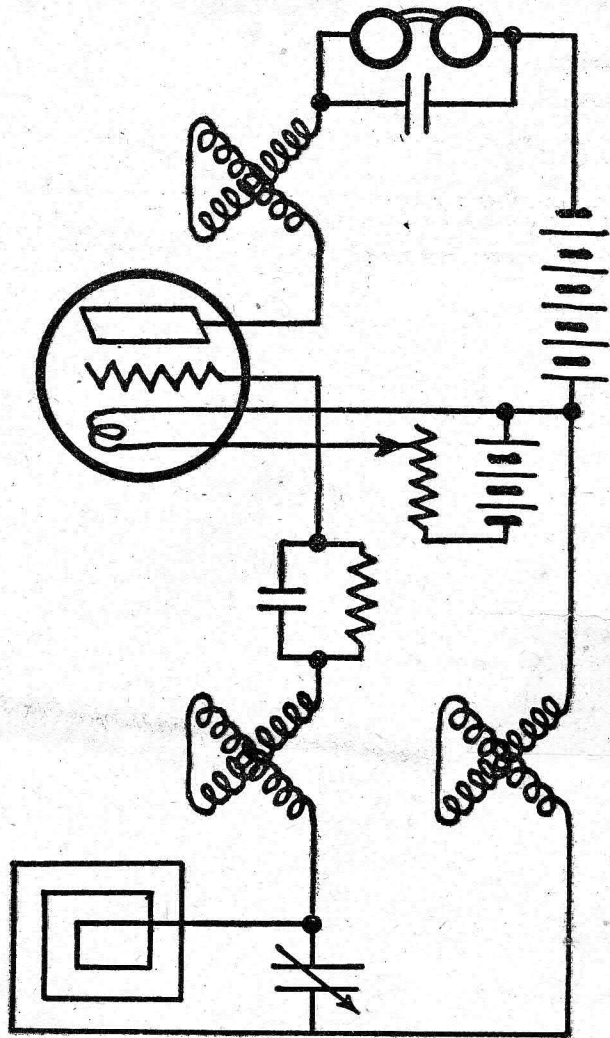
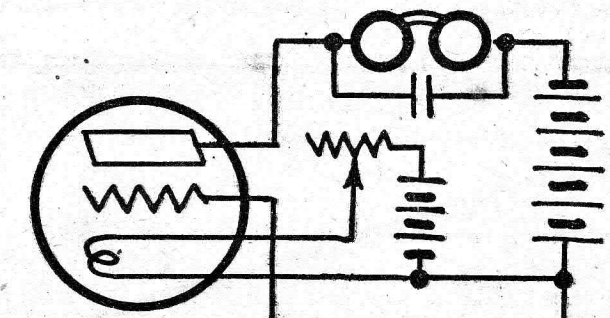
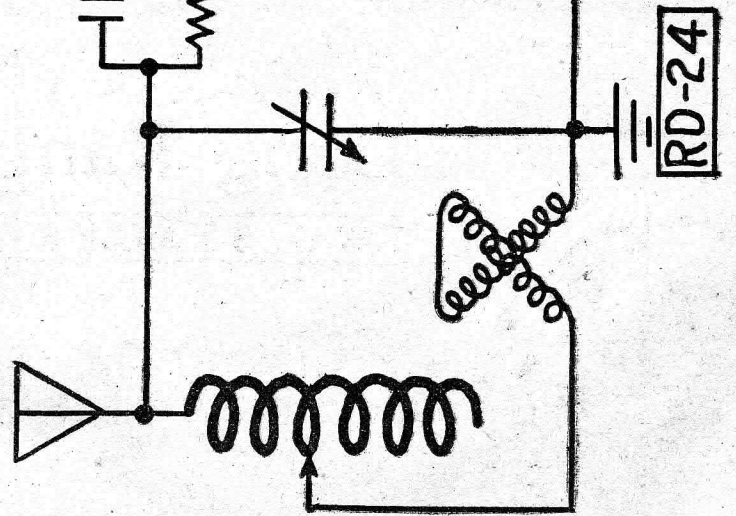
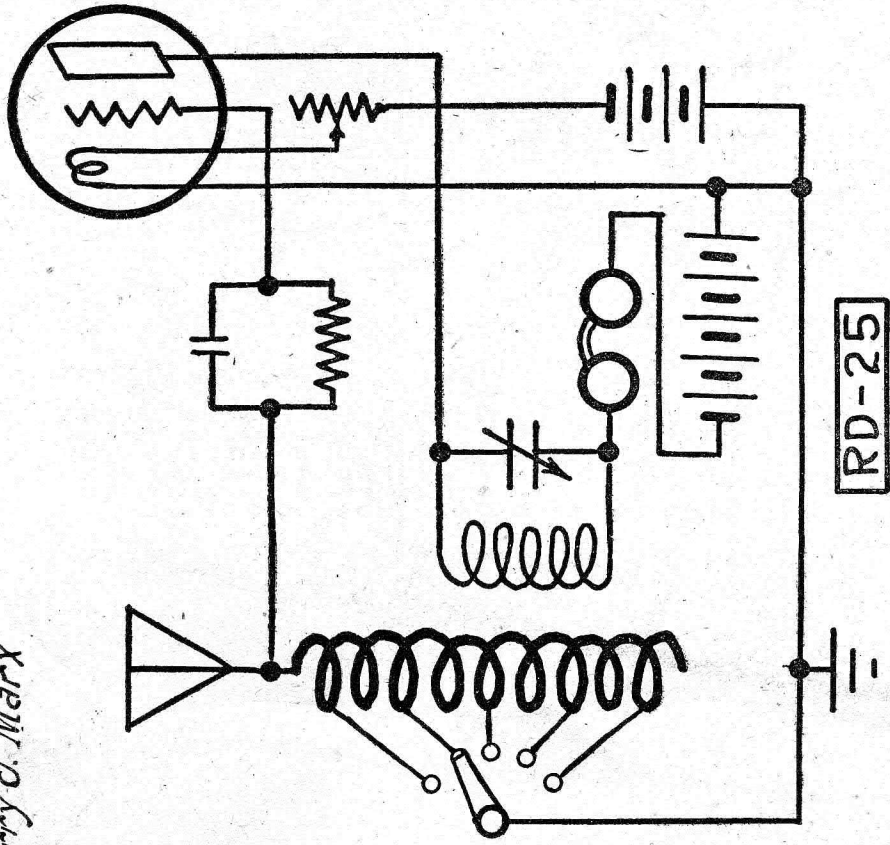
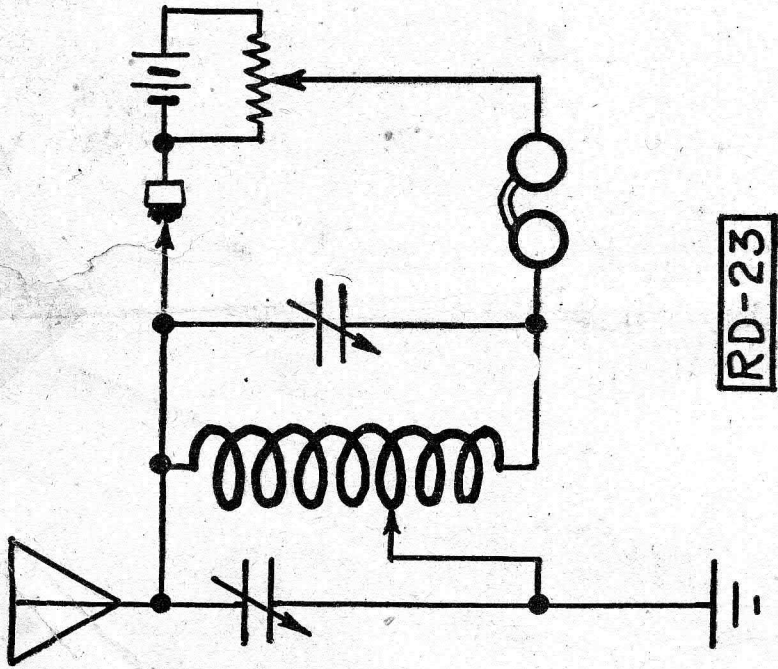
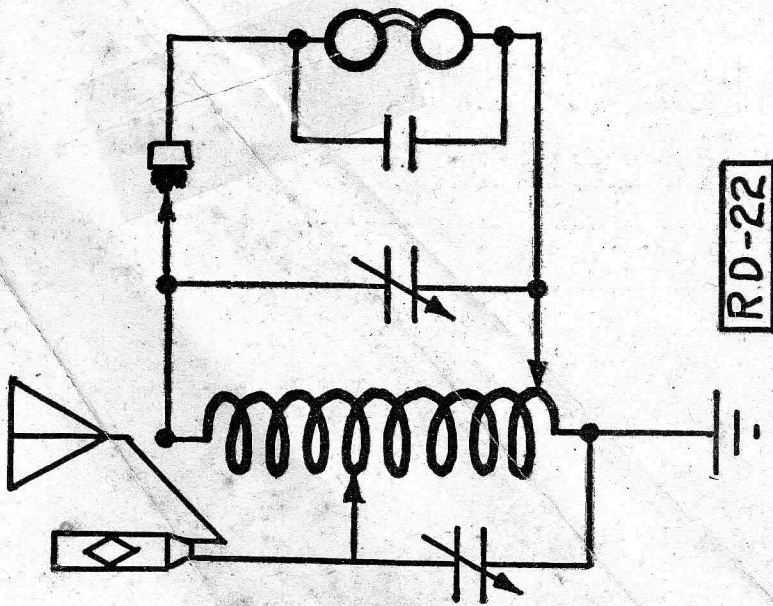

Hook Ups