

Radio

que and Only Station

EVERY WEEK

PROGRESSIVE

REG. U. S. PAT. OFF.

Vol. XIII

Copyright 1925
By Radio Digest Publishing Co.

SATURDAY,

BATTLE RUM WITH RADIO

WANT PATRON SAINT FOR RADIO SCIENCE

FRENCH PAPER CONDUCTS AMUSING REFERENDUM

Many Suggestions Submitted for Approval of Judges—Joan of Arc One of Favorites

PARIS, France.—Nearly every other art has a patron saint of its own, so why not Radio? One of the large magazines in this city is conducting an amusing referendum to decide which saint shall be selected to take Radio under wing.

To date there are a number of strong candidates for the honor. One contributor gives lengthy quotations from the "Histoire de Saint Antoine de Padoue" in support of his choice.

According to this history the saint while preaching in the streets of the little village of Saint Pierre des Quatre Chemins, was observed to appear suddenly in the church where he chanted the lesson of the day with great vigor. This is taken by the contributor to show that Saint Antoine at this early date had solved the problem of transmitting both his voice and his image with convincing thoroughness.

Sainte Jeanné d'Arc is proposed by many because she heard voices. But it was objected that she was only a receiver and never transmitted. Saint Antoine still seems to be leading the field, however. The contest has excited considerable interest in all parts of France.



Above is Miss Corynn Kiehl, a talented and youthful pianist, who is heard regularly from the Post Intelligence station, KJR, in Seattle, Washington. To the left: Leyla Georgy, well-known actress, who was recently interviewed by "Terese" from WGBS in New York. To the right: Ada Belle Files, singer of operatic selections, who is heard from WGN, Chicago.



To the left: Carl Ruopoli "Collegian's" orchestra, one of the regular features at CKY. Below: D. F. R. Coats, manager and announcer at CKY.

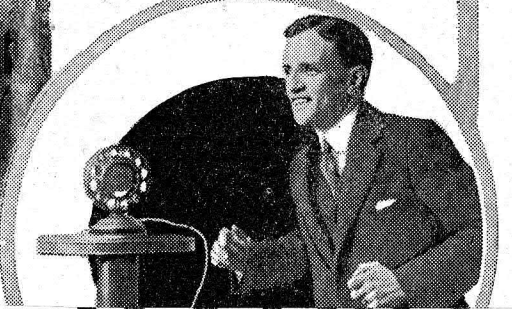

INSTALL SETS IN VESSELS OF COAST PATROL

Combine Code, 'Phone

Hope to Anticipate Plans of Booze Smugglers and Dry Up Eastern Ports

By L. M. LAMM

WASHINGTON, D. C.—Conviction that rum runners are using Radio communication between their boats and several illegally operated stations on shore has led prohibition officials to take steps in combatting the difficulty by a coast Radio system with which the runners can be met on their own ground.

These stations and marine sets will provide adequate means of communication between government land stations and the fleet of chasers now attempting to blockade the flow of liquor into the eastern states.

In connection with the use of Radio by liquor smugglers it is interesting to note that about a year ago a station on the west coast was dismantled after it was proven that signals for the movement of the smugglers were being sent, using musical numbers as a code.

(Continued on page 2)

CONSENSUS OF OPINION VOTE

Send to Radio Digest, 510 N. Dearborn Street, Chicago
To be forwarded by Radio Digest to the Department of Commerce for the attention of members of Congress.

- 1. Do you want less class B (500 watts or more power) stations?
2. Shall B stations be reduced to 94 in number, so that they can be accommodated satisfactorily in the "ether roadways" now available for the use of broadcasting stations?
3. How far away, approximately, is the nearest class B station?
4. Are you troubled by B stations heterodyning and interfering with one another?
5. Have you read a description of the Kintner plan?
6. Are you in favor of it or some similar plan which will help clear the air of the present "traffic" congestion?
7. Do you favor the appointment of an unbiased, non-partisan broadcasting control board for the settlement of all differences pertaining to broadcasting and the interpretation of present or future Radio legislation?
8. Include separately a list of five stations you like most and five you dislike most.

How many members Name
in your family?
Address
Are all of the same mind as yourself? City, County, State.
(Write to Radio Digest if more blanks are desired)

M'NAMEE TOPS HAY IN GOLD CUP AWARD

"SOLEMN JUDGE" TRAILS AS CLOSE SECOND

Eleventh Week Brings Many Shake-Ups—Positions of All But Two Change

Graham McNamee, New York's favorite voice and WEAJ announcer, broke down the famous lead which George Hay had held till now in the 1925 Radio Digest Gold Cup Award, and at the close of last week topped the list with "The Solemn Old Judge" close behind. The unexpected has happened. Competition is growing tense.

Who will be the world's most popular announcer for 1925 when the smoke of battle has cleared? Who will be in the top sixteen?

Less colorful, perhaps, than the wonderful race McNamee is giving last year's cup winner are other changes in standing during the week. But the positions of all but two of the sixteen leaders changed during the week.

Many Leaders Climb and Fall

The Hired Hand, WBAP, and Henry Field, KFNF, interchanged places again this week, putting the former in third place and dropping the latter to fourth. H. W. Arlin, KDKA, displaced Gene Rouse from fifth place, and left his old post, sixth, to Rouse.

Lucky it would seem are seven and eleven, for the contenders who occupied those positions last week still hold them. They are Lambdin Kay, WSB, and Stanley Barnett, WOC, respectively.

W. G. "Bill" Hay, KFKX, made a recovery and climbed back from tenth to eighth place. Meanwhile N. Dean Cole, WHO, came down from eighth to ninth. Charles Erbstein, WTAS, mounted two rungs and now is tenth.

Three candidates whose names were not in the first sixteen last week, have made their appearance or reappearance in that group. These are Leo Fitzpatrick, WDAF, Fred Smith, WLW, and Frank S. Lane, KFRU.

Standing of Top Sixteen

The standing of the sixteen leaders with the total number of votes received at the close of last week is as follows:

Table with 3 columns: Position, Name and Station, Votes. Lists top 16 performers and their vote counts.

There were no new nominations last week. Evidently the 158 nominees already in the race are deemed enough by the invisible audience.

How to Vote and Get Bonus

Don't miss a single ballot, for when these are turned in to Radio Digest in a group of CONSECUTIVE numbers, extra bonus votes are allowed the announcer for whom you are voting.

The ballots, top of page two, numbered consecutively, will appear in each issue of the Radio Digest until the close of the contest, with the August 22 number.

Each of these ballots will count for one vote when sent in separately. You can hold these ballots until you have 4 that are consecutively numbered, and when they are sent in a bonus of 8 votes will be allowed for your favorite announcer.

For each 8 consecutively numbered ballots your candidate will receive a bonus of 20 votes. For each 12 consecutively numbered ballots, 30 votes. For each 16 consecutively numbered ballots, 40 votes. For each 20 consecutively numbered ballots, 50 votes, and for each 22 consecutively numbered ballots, 60 votes bonus will be allowed.

Send nominations or ballots to the GOLD CUP AWARD EDITOR, Radio Digest, 510 N. Dearborn St., Chicago.

CKAC to Help Tourists

MONTREAL, Can.—Fans contemplating a trip to this city need not hesitate to bring along their receiving sets. CKAC will keep them posted as to the interesting points to visit, also the conditions of the roads.

British Air Performers Ask (and Get) Big Fee

Actor Receives \$1,100 for Single Radio Appearance

LONDON.—Broadcasting fees are rising rapidly here. Two years ago the British Broadcasting company offered world-famous artists as little as \$5 for "expenses." Quite recently an actor, who had been holding out for his price, was paid \$1,100 for performing in a short item in an evening's program from 2LO.

Distinguished artists belonging to the Actors' Union figure that each person who listens when a person of note is performing should pay him one-half cent.

CONGESTION VOTING BLANKS NOW READY

CHICAGO.—Radio Digest's campaign for less broadcast congestion and a feasible plan for regulating the number of stations and their broadcasting schedules, still continues to hold the interest of thousands of Radio listeners from coast to coast.

Although tabulation of the "Consensus of Opinion" votes has not kept pace with the rapid influx of these ballots, it is believed that over twenty thousand of these have been returned to date. Radio Digest has prepared a large supply of printed "Consensus of Opinion" voting forms, which may be had by any listener in, Radio club or broadcasting station wishing to aid the campaign by distributing and collecting these votes.

Worse Congestion Ahead?

With regard to the crowded condition of the air, a recent bulletin from the department of commerce in Washington states that during the past month more than one hundred applications for new wave lengths have been received from organizations and individuals contemplating the erection of new broadcasters.

Without the Kintner plan or some similar device to keep these stations under control, it is pointed out that Radio listeners are likely to be greeted with more chaos than ever before.

FIGHT RUM WITH RADIO

(Continued from page 1)

The government land stations presented no difficulty, but to provide a set which could be installed on the cramped little chasers and withstand the hard service it must necessarily receive, proved a hard question. None, or at least very few of the chasers carry men aboard who are familiar with Radio. No provision is made for carrying a regular operator. Apparatus would of necessity be compact and easily operated.

To meet this requirement, a special set has been designed by experts who have studied the conditions existing in the patrol boats.

The equipment is built to meet telephonic communication over the water for fifty miles in full daylight and telegraphic communication under the same condition for 100 miles. To fulfill the requirements for utmost simplicity, wave lengths ranging from 120 to 176 meters for the transmitters, 100 to 200 meters for the receivers, were adopted.

Telegraph keys will be installed on all the sets so they may be used by those ships having personnel able to use them.

Will Not Hear Concerts

As it would be impractical to have the men on the boats listening in at all times, certain hours will be set aside in which orders and instructions will be interchanged. The construction of the sets is designed for official use only and cannot be used for the reception of Radio concerts because of this construction.

The first sets will be installed within a short time and it is believed that as time passes the service will be able to learn a great deal about them and that new and improved methods of operation will be evolved from actual operation.

By this new system of communication the coast guard will be put on an equal footing with the rum runner so far as information of movement and operation is concerned in the great battle of speed and wits.

Scientists in South America are now using Radio to track down destructive worms.

CONTENTS

Radio Digest, Illustrated, Volume XIII, Number 9, published Chicago, Illinois, June 6, 1925. Published weekly by Radio Digest Publishing Company, 510 N. Dearborn Street, Chicago, Illinois. Subscription rates, yearly, Five Dollars; Foreign Postage One Dollar additional; single copies Ten Cents. Entered as second class matter at the post office at Chicago, Illinois, under the Act of March 3, 1879.

Table listing contents: All the Live News of Radio, CKY, Manitoba's Unique Station, Advance Programs for the Week, An Evening at Home with the Listener In, a Chart in Eastern, Central and Pacific Time, showing when to listen in for your favorite stations, Editorials, Indi-Gest, and Condensed by Dielectric, Recent Advances in Radio Frequency Amplification, Part II—by Milo Gurney, A. B. C. Course in Radio Fundamentals, Chapter XI—Instruments of the Electrodynamometer Type, by David Penn Moreton, Changing Regenerative Set to a Reflex, Questions and Answers, Directory of Radiophone Broadcasting Stations, Part IV.

Looking Ahead

WAHG, "Wait and Hear Grebe," the Station of the Syncrophase Makers, will be pictured and described in next week's issue. WAHG has many features that make it stand out apart from other stations, and is always guided by the fertile brain of Heber MacDonald, staging some novel stunt. Watch for this.

Going Further Into His Preliminary Study of Radio Frequency, which will lead to the revolutionary new method of balancing capacities around a vacuum tube, Milo Gurney, in his exclusive articles for Radio Digest, will next take up antenna compensation and the famous neutrodyne angle. Don't miss a single article of this series.

McNamee Passed George Hay in the Gold Cup Award this week, but will the famous announcer of WEAJ's linked programs keep his lead? Things are popping in the contest. Watch for next week's standing.

What's the Solution to the Cross Word Puzzle given on page 7 this week? The solution will be published next week.

The Generation of Electrical Energy by batteries of the type known technically as primary cells—which in everyday language means all batteries other than storage—forms the basis of Professor Moreton's next "A. B. C." article.

Newsstands Don't Always Have One Left

WHEN YOU WANT

Radio Digest

YOU WANT IT!

BE SURE OF YOUR WEEKLY COPY BY SUBSCRIBING NOW

SEND IN THE BLANK TODAY

Form for subscription: Publisher Radio Digest, 510 N. Dearborn St., Chicago, Illinois. Please find enclosed check M. O. for Five Dollars (Six, Foreign) for One Year's Subscription to Radio Digest, Illustrated. Name, Address, City, State.

CKY, Manitoba's Unique and Only Station

Below is J. E. Lowry, Commissioner of Telephones in Manitoba and the presiding genius at CKY and an engineer of wide note.

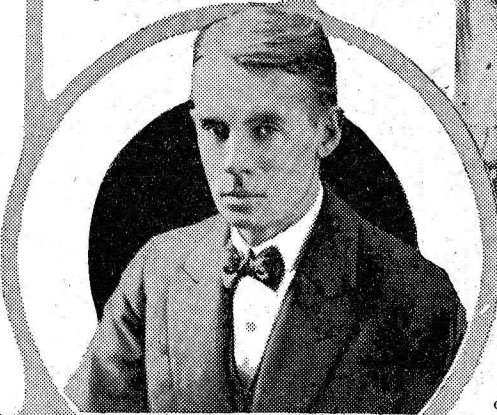

One of the masts of CKY. Note the peculiar construction, not commonly seen in the United States.

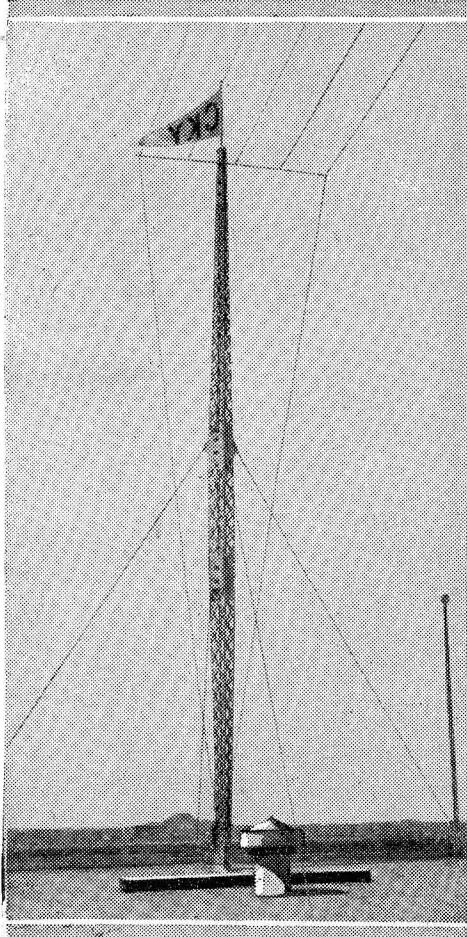

"Bill" Duffield, chief operator at CKY. To right: Herbert Armitage, CKY's wizard of the ivories.

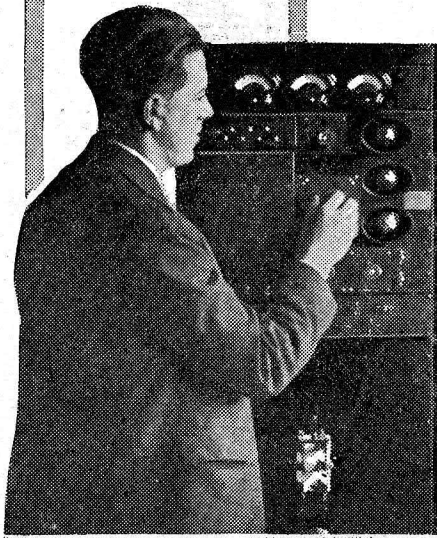

To the left: Carl Ruopoli "Collegian's" orchestra, one of the regular features at CKY. Below: D. P. R. Coats, manager and announcer at CKY.

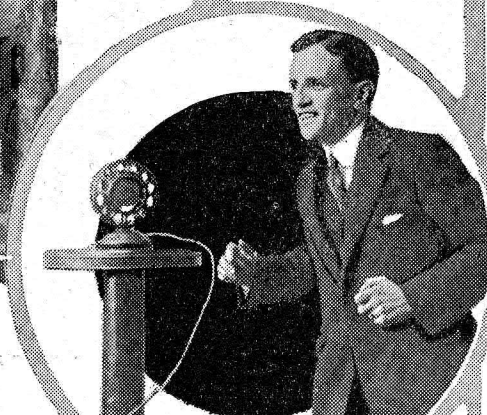

Below is Miss Lillian Shaw, assistant announcer and accompanist at the Canadian station.



Prof. W. T. Allison, in charge of the educational broadcasting program at CKY.



At the organ is Herbert P. G. Fraser of the Fort Rouge Methodist Church, a regular feature.

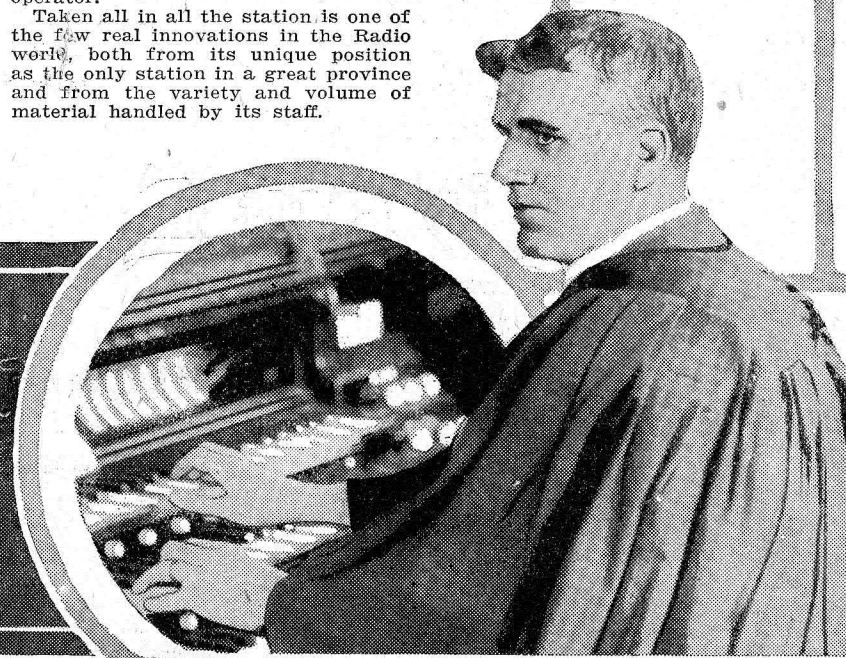

TWO years ago two privately owned broadcasting stations in Manitoba, Canada, quit broadcasting. They did it under one of the most unusual arrangements ever tried in the world of Radio. It was this. All the interests whose attention had been attracted to Radio entered into an agreement that they would lay aside their right to individually open broadcasting stations and center their efforts on one great station to be erected upon a sound and permanent basis. They further agreed to cooperate with the Minister of Telephones, under whose direction the station would fall, in making the new central outfit maintain the necessary high standard of entertainment and education its exclusiveness would demand.

And so CKY, "Manitoba's Own Station," at Winnipeg, was conceived.

Under the direction of the Dominion authorities the station was planned and erected. That it might be heard without difficulty in all parts of the country a 500-watt transmitter was installed.

But the agreement was not so popular as might be visioned. While one part of the public lauded the move, another set up a hue and cry condemning it. The latter maintained that broadcasting rights should be open in Manitoba to all who desired to erect stations. The babel continued for some time.

While this was in progress CKY was pioneering the project through. Today it is admitted by all those who are fair minded that the experiment has been a success. Its advance and achievement in public has been steady and rapid. In educational work it is admittedly the leader in Canada. In entertainment it has reached a high rating and evoked much favorable comment.

The scope of its activity, as some might expect, is an exceedingly wide one. It ranges all the way from the broadcasting of the best music available to instruction and questions and answers for farmers.

The former entertainment is supplied by scores of individual artists and several orchestras and bands of Winnipeg. Under the direction of a comparatively small staff, the big field is covered.

In connection with the Agricultural college hundreds of queries from the farmers of the province are answered. Lectures on farm subjects of general interest and education are given at frequent intervals by instructors at the school. These range from poultry practice to crop rotation.

In the afternoon, lectures on history, mathematics, geography and innumerable other academic subjects are given

for the benefit of outlying and country schools, which are equipped with loud speakers. In this manner and on these lectures, much of the fame of the institution as an educational force has been founded.

CKY boasts of being the first station in Canada to broadcast a church service. It was done in 1923 for the first time and since that date it has become a regular feature. At present the station lists more than a score of churches from which services are broadcast in turn.

So successful has the single station project worked out that recently a huge association, called "The Associated Radio of Manitoba" was formed. This consists of representatives of the Provincial Telephone System, the Radio trade and the listeners in. At present its attention is being directed to the study problems of interference and in making recommendations to the government in cases where contention has arisen.

About the station proper. D. R. P. Coats is the manager and chief announcer. Mr. Coats is well known not only in this capacity, but also as an elocutionist of high ability. His reading from Service and Kipling has attracted wide attention.

One of the first stations in Manitoba was erected by J. E. Lowry, commissioner of telephones in the Province of Manitoba and at present the director-general of CKY. It was as a result of Mr. Lowry's negotiations with the former stations that the present plan was adopted and it was under his direction that the present wide Radio educational system was inaugurated. In passing it may also be said that to Mr. Lowry belongs the credit for CKY's record in rebroadcasting long distance stations and for its great network of connections with remote control points. Although it is not generally known, CKY was one of the real pioneers in rebroadcasting. It was the first Canadian station to rebroadcast an American station successfully. In the latter work now it considerably outnumbers any other station in the Dominion.

Aiding Mr. Coats in the announcing and entertaining is Miss Lillian Shaw. According to Mr. Coats she is the official accompanist, stenographer and is the only one known "who has accomplished the difficult task of putting a musical lilt into the reading of market reports."

The mechanical and operating end of the plant is taken care of by "Bill" Duffield, former British Navy wireless operator.

Taken all in all the station is one of the few real innovations in the Radio world, both from its unique position as the only station in a great province and from the variety and volume of material handled by its staff.

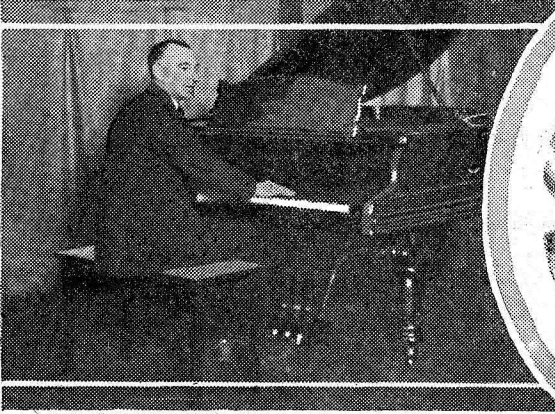

PLAN USE OF RADIO PLOTTING COUNTRY

AIRPLANES TO COOPERATE IN GIGANTIC TASK

Entire Project Will Take From Ten to Twenty Years—Estimated Cost \$50,000,000

WASHINGTON, D. C.—Airplanes and Radio will cooperate in plotting a complete topographical survey of the United States, work on which has been intermittently going on for forty-five years.

Army airplanes are to be utilized and the Radio will be extensively used for keeping in contact with these planes and receiving reports from them. This has come about as a result of the appropriation obtained at the last session of congress, and will cover annual stipends covering a period of twenty years, to complete the delayed work.

Under present plans there will be from 800 to 900 men, about 275 of whom will be experienced engineers, working continually in the field during the summer of 1925. Next year funds sufficient to keep from 1,500 to 1,800 men busy during the spring, summer and fall are hoped for. Estimates put the cost of the entire work, which will continue for from ten to twenty years, at about \$50,000,000.

Herbert H. Hoover, secretary of commerce, is one of the advocates of the project. It will be in cooperation with his department that the planes will use Radio for innumerable purposes.

There is an increasing need for more extensive and better maps for the use of air pilots. They must be guided by ground features, and flight maps must be prepared which will accurately locate such features. There is no such data for a large part of the country, and it can be obtained only by the completion of the topographical map.

Publishes Radio Photo Book

WASHINGTON, D. C.—"Vision by Radio—Radio Photo" is the title of a book just published by C. Francis Jenkins, a local Radio inventor. The book takes up the work Mr Jenkins has done along the lines of sending photographs by Radio and discusses also similar work of others.

AWAY UP WHERE ICEMEN STARVE

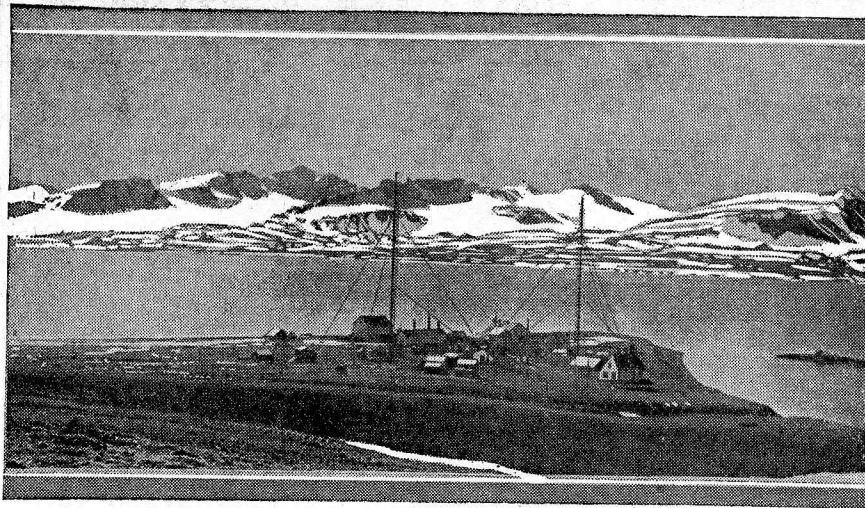

The farthest north Radio station, which has Radiotelegraph equipment only, is this group of buildings at Greens Harbour, Labrador. It is one of the stations with which the last MacMillan Polar expedition communicated, and will be in communication with the next MacMillan expedition which on June 17 will leave the United States.

Foreign Notes

Research work is now going forward in the Soviet laboratories at Nijni-Novgorod, where it is said extensive preparations are being made to develop high power Radio tubes of the 100-kilowatt water-cooled type.

One lifeboat out of every ten carried on British steamers must be equipped with Radio sending apparatus.

Radio has gripped the entire city population of Russia and is beginning to spread to the rural districts, according to reports from Moscow.

To Sheffield belongs the distinction of having the first real Radio-equipped house in England. Every room is wired for Radio.

The Radio policeman is on his rounds in Britain. When a person moves, he is tracked down for non-renewal of his license.

Arrangement Complete to Mike British Turf Classic

LONDON.—The broadcasting of the Derby, the blue ribbon of the English turf and one of the most famous races in the world, has been definitely approved by Sir William Mitchell-Thomson, post-master-general.

Arrangements have been made to lay a line along the track and to couple this up with an existing telephone circuit half a mile away. The actual microphone will be erected by the B. B. C. at the most suitable point to broadcast the shouts of the crowd, the thunder of the galloping horses, and the hundred and one other sounds of this race of races.

CONTINUE SWIMMING INSTRUCTION AT WOR

Frank E. Dalton's Lessons Via Ether Prove Popular

NEWARK, N. J.—Frank E. Dalton's series of broadcast swimming instructions recently inaugurated by WOR are being continued as a regular Monday evening feature. The course by Mr. Dalton is most seasonable, and after his first few Radio lessons it is the consensus of opinion that he has the faculty of imparting instruction on a subject which might very readily be considered impractical by Radio.

To create the atmosphere of the seashore while broadcasting, Mr. Dalton has ingeniously brought to the studio of WOR a "wave-making" machine, similar to those used on the stage in marine scenes.

Scores of WOR listeners have written to the Dalton Swimming school to the effect that the swimming instructions have given them confidence in the water which will add materially to their enjoyment during the coming summer season.

Motorcycle House-to-House Testers Awaken Sleepers

JOHANNESBURG, South Africa.—Light sleepers who were awakened at 3 a. m. by a motorcycle carrying two men rushing madly past and returning again in a few moments, had their anxiety and curiosity relieved the next day when it was learned that the men were two Radio enthusiasts who were testing the relative reception, from Station KDKA, Pittsburgh, Pa., at their respective homes, which are some miles apart in different residence districts.

Station WEW Celebrates

ST. LOUIS, Mo.—A special program was recently arranged at Station WEW, St. Louis university, to commemorate the fourth anniversary of Radio-telephonic installation. WEW is a pioneer broadcasting station in the United States and the oldest station in Missouri, having entered the field April 26, 1921.

Because dust is composed partly of metal, the volume of sound in the receiver will be cut down if the inside of the set is permitted to become dirty.

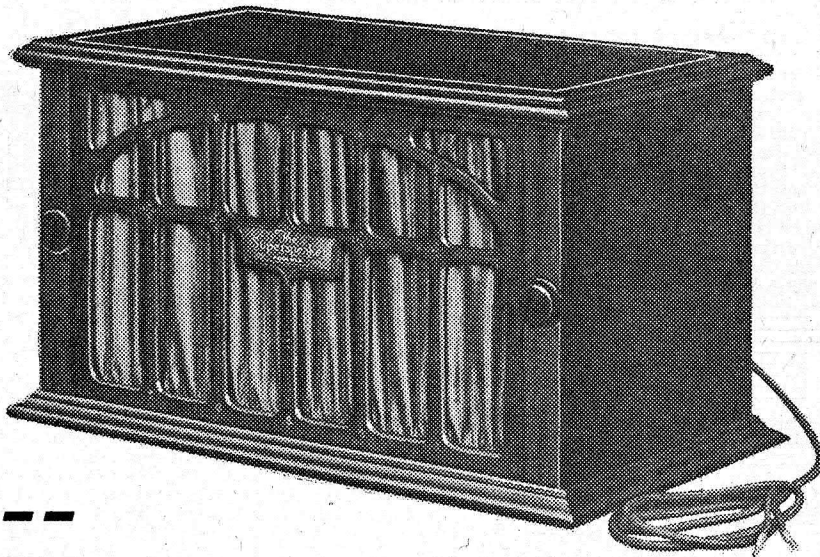

And Now--

The Superspeaker Console

In Performance, it's a Superspeaker—enough said. In Appearance, it's the finest piece of Radio cabinet work you have ever seen.

Just what you'd expect from two years' experiment and development by an organization with a record of leadership in the field of loudspeakers.

See it! Listen to it! Enjoy its ability to improve the appearance and performance of your set.

Of finest American Walnut or the new Clairemount Mahogany—Top inlaid with Arlington Ivory—Leather composition grill, richly draped with silk—Volume controlled by ebony knob—Superspeaker-Vemco Reproducing unit—Superspeaker-material concealed horn with full floating mounting. Overall size 10¼ x 17¾ inches, 10 inches high. Ask any Jewett dealer. Price \$40.00; west of the Rockies, \$42.50.

The Jewett Superspeaker—All that the name implies. Recommended by experts everywhere. Price \$30.00.

The Jewett Superspeaker Console—A handsome cabinet with Superspeaker performance. Enough said. Price \$40.00. West of the Rockies, \$42.50.



The Jewett Parkay Cabinet—With parquetry top. Puts the amateur on a par with the most exclusive cabinet worker. All sizes, prices to correspond.

The Jewett Micro-Dial—Makes tuning 50 times as accurate. Fits any set. Needs only a screw-driver to install. Price \$3.50.

JEWETT RADIO & PHONOGRAPH COMPANY
5668 TELEGRAPH ROAD
PONTIAC, MICHIGAN

Factories: Allegan, Michigan—Detroit, Michigan—Pontiac Michigan

Canadian Sales Offices:
Walkerville, Ontario

Export Sales Offices
116 Broad St., New York City

Jewett Quality Products

The Jewett Vemco Unit—Makes a loud speaker out of your phonograph. The Reproducer used in the Superspeaker. Price \$12.00.

The Jewett Superspeaker High-boy Houses Radio set and all-batteries. Superspeaker built in. Takes Radio into the realm of fine furniture. Price \$130.00.

PLAN TO STOP LAKE BOAT INTERFERENCE

RECOMMEND THAT STOP BE PUT TO SPARK NOISES

Practice of Transmitting Unofficial Conversation to Be Discontinued Under New Plan

DETROIT.—One of the most important agreements that has been reached since the advent of Radio was made by officials of the American and Canadian governments in a conference held at Detroit recently at the instigation of the Canadian government.

Spark transmission by lake boats and land stations will be moved out of the range of the broadcast listener and his set effective midnight July 15, 1925. There is nothing in Radio that has marred Radio reception for those residing in the Great Lakes region like the broad spark transmitters that have been used in handling lake traffic.

The recommendations made by the conference will be forwarded to the respective governments and undoubtedly they will be accepted. They are, as adopted:

That all Canadian and American coast and ship stations on the Great Lakes open for general public service business must be equipped to work on a wave length of 715 meters which will be the normal wave length of the station.

That the wave length of 875 meters is authorized for the handling of general public service correspondence. The use of this wave by coastal stations is optional.

That communication between a coastal station and a station on shipboard or between ship stations shall be exchanged on the part of both by means of the same wave length.

That for general public service, communications between ship and shore and ship and ship when working with stations other than the nearest station must be on a wave length of 875 meters or higher. Communications with a distant station will not be permitted if interference with the nearby station results.

That all correspondence transmitted from a ship or shore station will be in a regular message form and copies of these communications must be placed on file.

The practice of transmitting notes under the prefix SVC or carrying on unofficial conversation must be discontinued.

Make Movies in Studio

LOS ANGELES.—At Marion Davies' recent broadcast from KFI a motion picture record was made of the event. The entire department is wired for moving picture lights, and may be converted into a motion picture studio within a few minutes.

WOOD TELLS ABOUT THEATER FROM WBZ

AL JOLSON is a nationally known celebrity of the footlights. The inimitable black-face comedian is known and admired by theatergoers the country over. But after one sees him star in one of his productions that is the last one sees of "Al" Jolson. What does he do after the performance? Does he talk of interesting topics? Is he a thinker, or is he as he makes out to be on the stage, a natural comedian? Many theatergoers ask the same questions about other illustrious stars of the drama or musical comedy stage, but for the most part these queries go unanswered for years, unless one is afforded the privilege of making the acquaintance of members of the stage fraternity.



A. L. S. Wood

A. L. S. Wood, dramatic critic of the Springfield Union tells about them once every week at Westinghouse Station WBZ at Springfield, Mass.

Mr. Wood personally reviews every current theatrical production in the metropolitan cities once every so often. He interviews the actors, and every Thursday night at WBZ he tells the listeners of the shows he has seen. And he relates intimate chats with the show people. He entitles his talks "At the Theaters," or "Down the Center Aisle," and they are appropriately named for they put the public right in the center aisle from where they can satisfy their curious minds as to "Al" Jolson or any other show-man of their fancy.

KNOW YOUR SLOGANS? SOLVE THIS

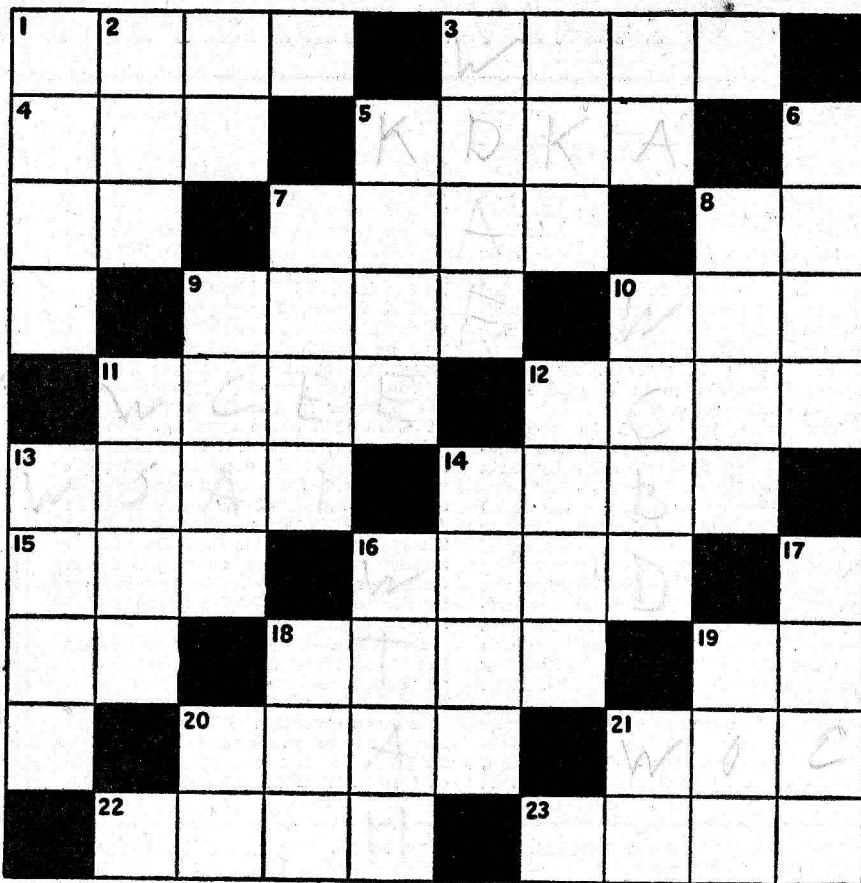

THIS cross-word puzzle was sent in by F. V. Chagnot of Youngstown, Ohio. So far as is known, it is the first one using station call letters and slogans exclusively in the solution. The interlock is not perfect, but that is an impossibility because with one or two exceptions, all stations use calls of three or more letters. Despite this fault the puzzle is interesting and should furnish quite a little sport—and some teasers.

The solution will be published next week.

HORIZONTAL

- "Quality First."
- "The Island of Enchantment—Where the World's Best Coffee Grows."
- "The Land of Eternal Summer."
- "The Pioneer Broadcasting Station of the World."
- "Working for All Alike."
- "The Voice to the Millions."
- Big Brother of "Willie, Tommie, Annie and Sammie."
- "The Heart of Ohio."
- "United States Playing Card Co."
- "The Voice of the Great Lakes."
- "L. Bamberger & Co."
- "The Voice of the North Country."
- "Something for Everybody."
- "On the Dells of the St. Croix."
- "Where the West Begins and the State Where the Tall Corn Grows."
- "Three Weeks Below Quebec, Where Civilization Nearly Ends."
- "The City Beautiful on the Old Mississippi."

VERTICAL

- "Where Prosperity Begins."
- "World Crier."
- "Night Hawks."
- "Your Service Station."
- "The Voice from the Heart of the Commonwealth."
- "The Friendly Voice."
- "Lincoln Hoot Owls."
- "Royal Order of Prevaricators."
- "Where God Rules, Man Prospers."
- "In the Land of the Sky Blue Waters."
- "Where All the Oceans Meet All the Railroads."
- "Acknowledged by All Others to Be the Second Best Mining College in the World."
- "The College on the Hill."
- "The Voice from the Storage Battery."
- "Voice of the Prairies."
- "The Voice of the Capitol."
- "The Sunshine State of America."

RADIO TEACHER IS NEW PROFESSION

Inaugurate Broadcast Instruction as Integral Part of Schooling at Oakland

SAN FRANCISCO.—Classroom instruction by Radio will now become an integral part of the Oakland (California) Public School's system, it was announced today. Experiments just concluded, which were commenced a year ago, have convinced school officials that broadcasting lessons into classrooms of several schools at one time is a valuable educational medium, worth continuing as a regular thing, under careful supervision.

During the past year experiments were carried out with the cooperation of KGO, the Pacific Coast General Electric Station, located here, covering the general subjects of "Science," "Arithmetic," "Drawing," "Penmanship," "Creative Composition," "Thrift," "Vocational Counseling," "How to Read a Book," and "Manual Activities." Results attained are said to be astonishing, drawing and penmanship proving most easily adaptable to Radio. Each of the general subjects given were worked out for the fifth, sixth, seventh, eighth, ninth and tenth grades, with good success, according to Dr. Virgin Dickson, head of the Research Department of the Oakland schools.

Each lesson broadcast was carefully prepared by an expert, a supervisor particularly skilled in his or her subject. Days were spent on a single lesson which required sometimes not more than fifteen minutes to give over Radio. All instruc-

tors went to the KGO studio to teach their invisible classes. Proper notices, and instructions, were sent out by the department to ten principals whose schools were officially selected to listen in during the experiments.

Dallas Plans Greater Broadcasting Station

New Westinghouse Plant to Replace Old WRR

DALLAS.—Donations of more than \$12,000 have already been received for the construction of a new municipally owned Radio broadcasting station for Dallas, Texas, which will replace the old plant, WRR, recently condemned because of its unfitness for further use.

WRR was the first municipally owned station in the United States and the second oldest in the world, according to a dispatch from the southern city.

The erection of the new plant was decided upon after the matter had been discussed by a committee of business men representing the city before Commissioner Turley. The new installation will be of the Westinghouse make, with a capacity of 1,000 watts, and will cost approximately \$18,000. Its construction will embody all the most advanced principles in Radio design and is expected to take its place as the finest broadcasting plant in the South. As yet no date has been set for the start in construction.

Suggestions for a slogan to be used in broadcasting are asked. They may be sent to W. J. Reid at 1603 Commerce street in Dallas.

GERMANY IS HIGHLY ORGANIZED IN RADIO

LISTENERS PAY LICENSE FEE OF \$25 ANNUALLY

High School Courses and Operatic Airs Part of Programs—Artists Paid for Services

BERLIN, Germany.—Radiocasting in Germany is an entirely different proposition to what it is in America, or even in other European countries. The receiver's license costs \$25 a year, and it is collected weekly by a government official, who has power to confiscate the set of any license-holder who is in arrears with his payments and hold it until he is clear on the books again.

The twenty broadcast stations in operation are all owned by the government, but are leased to private companies, which are required to organize their programs on a much more elaborate scale than is the case in England.

Obtain Best Music

For his \$25 the licensee has access to all the best music in Germany. The great operas are transmitted in full from the principal opera houses, and the Berlin Philharmonic orchestra and other famous bands are always available.

Some of the stations have organized opera companies, which perform in miniature opera houses with full orchestras and accessories, and high fees are paid to secure the best artists.

High school courses are a regular feature, and here again no expense is spared in securing the best available educationists on every subject. Eight different languages are taught in these courses and almost every branch of science. Thus for fifty cents a week a university curriculum is open to all.

Advertisements are transmitted freely at certain intervals, but no fan is allowed to listen to news for fear it should injure the newspapers.

Deny Secret Two-Way Radio Communication

Claim Experiments Are But Continued Research

LONDON.—Sir William Mitchell-Thomson, British postmaster-general, has issued a complete and emphatic denial of the statements circulated recently that two-way Radio telephonic communication has already been established between America and England by means of a new and secret system.

"This is not the case," declares Sir William. "The experiments so far made are a continuation of those announced to the press in May, 1924."

RADIO CLOWN PLANS TO ENCIRCLE WORLD

CHICAGO.—Bert Davis, "The Clown of the Air," is leaving Chicago June 14 for a globe-encircling motor tour of all principle broadcasting stations in the United States, Australia, Asia, Continental Europe and England. Accompanied only by "Static," a brown mongrel dog who likes everything but horses, Mr. Davis will go in his especially equipped touring car first through the East, arriving in New York in late July.



Bert Davis

His itinerary then will bring him back to Chicago in the middle of August, from where he will tour the Middle West, Rocky Mountain states, and the Pacific coast. His western goal will be San Francisco. Here he will sail to Australia, Asia, Continental Europe, and England will be next in order.

Speaking of his travelling companion, "Static," Mr. Davis said, "He's just a tramp—like myself."

"The Clown of the Air" began his career as a performer when as a youth he joined a circus as an acrobat. He almost became a dare-devil in a loop-the-loop act but was nearly drowned in a river in his first attempt. Casting aside dare-deviltry and acrobatics, he became a jockey, which occupation he pursued till vaudeville lured him to the footlights. Then along came Radio.

The car in which he will tour the world has on its top two miniature broadcasting station towers.

WSAI GIVES ANNIVERSARY PROGRAM

Saturday, June 6

Saturday, silent night for: AT9, CFAC, CHIC, GHNC, CHYC, CNRT, CKY, KFAE, KFDK, KFKU, KFKX, KFMQ, KFMX, KFRU, KLR, KLDS, KLY, KOB, WBAV, WBAV, WCAU, WCB, WCC, WDFW, WEAQ, WGB, WGI, WGR, WHA, WHAD, WHAZ, WHE, WHG, WJY, WKAQ, WLIT, WOAN, WOI, WRBC, WVIC, WWJ.

Atlantic or Eastern Daylight Saving Time Stations

CKAC, Montreal, Can. (410), 7:30 p. m., Harry Salter and his Windsor hotel concert orchestra; 8:30, talk on the attractions of the Province of Quebec; 10:30, Harold Leonard's Red Jackets.
CNRO, Ottawa, Can. (435), 7:30 p. m., Uncle Dick; 8,



Leon Chassy, director of the Meyer Davis orchestra, is a violinist of national reputation. He is well known in the South. The Meyer Davis orchestra is a special Sunday feature at KTHS, Hot Springs National Park.

Chateau Laurier concert orchestra; 9, J. Hughes Johnson, pianist; Ernest Botton, bass; French horn solos, Simpson Green; Jean Boyle, soprano; bagpipe soloist, Piper Sam Scott; F. J. Hornings, violinist; reading, Jean Boyle.
WAHG, Richmond Hill, N. Y. (315.6), 12-2 a. m., dance music.
WBBR, New York, N. Y. (272.6), 8 p. m., Dr. Hans Haag, violinist; 8:10, Fred Twarosch, tenor; 8:20, Bible questions and answers; 8:45, Dr. Hans Haag, violinist.
WCAE, Pittsburgh, Pa. (461.3), 8:30 p. m., dinner concert, William Penn hotel; 8, address, 8:15, Prof. Otto Kallais, pianist; 8:30, concert.
WCAU, Philadelphia, Pa. (245), 6 p. m., Hotel Pennsylvania inter-fraternity dance orchestra; 8, recital; 10:30, Charles Verna's dance orchestra.
WEAF, New York, N. Y. (491.5), 6-7 p. m., dinner music, Waldorf-Astoria; 7-7:15, Lulu Phillips, soprano; 7:15-7:30, Maurice Nadelle, pianist; 7:30-7:50, "Trips and Adventures," Fred Turner; 7:50-8, Jules Schwarz, baritone; 8-8:15, Maurice Nadelle, pianist; 8:15-8:45, Huyler's Foremost Four; 8:45-8:55, Jules Schwarz; 8:55-9:25, Daisy Jean trio; 9:25-10:15, Mascato vocal ensemble; 10:15-10:30, Ralph Reichenthal pianist; 10:30-11, humorous half hour; 11-12, Vincent Lopez's Hotel Pennsylvania orchestra.
WFI, Philadelphia, Pa. (394.5), 3 p. m., Deleo piano quintet; 4:30, Haggas Collegians dance orchestra; 6, Rey Elrae and his orchestra; 6:30, Bellevue Stratford concert orchestra; 7, bedtime stories; 8:30, chorus rendition of "Song of Songs"; 9:30, Mandolin orchestra.
WGBS, New York, N. Y. (315.6), 6-6:30 p. m., Uncle Geebee; 6:30-7, the Amphibians; 7:30-8:30, Armand Yecsey concert orchestra; 8:30-9, Adolina Vassri, soprano, and Margaret Hamill, pianist; 9:30-10, Paul Ray, violinist; 9:30-10, Clare Schaeffer, bass; 10-10:30, Koltun piano quartet; 10:30-11:30, California Ramblers.
WGR, Buffalo, N. Y. (319), 2:30-4:30 p. m., WGR's afternoon program, A. J. Erisman, director.
WHAR, Atlantic City, N. J. (275), 7:30 p. m., Seaside hotel trio; 9, Shelburne hotel concert orchestra.
WHM, New York, N. Y. (360), 7:30-7:35 p. m., health talk, Dr. Landis; 8:30-9, Strand Roof orchestra.
WIP, Philadelphia, Pa. (508.2), 3 p. m., Society dance orchestra; 6:05, songs, Charles Higgins; 7, Uncle Wip's bedtime stories; songs, Margaret Keenan; 8, York Pennsylvania community night, featuring "The Gondoliers," York Operatic society; 10:05, Howard Lanin's dance orchestra.
WJAR, Providence, R. I. (305.9), 7:05 p. m., studio program.
WJZ, New York, N. Y. (454.3), 4-4:02 p. m., baseball scores; 4:02-4:30, Marvellan Serenaders; 4:30-4:32, baseball scores; 4:32-5:30, tea music; 5:30-5:32, baseball scores; 5:32-6, daily reports; 8-8:02, baseball scores.
WLIT, Philadelphia, Pa. (394.5), 4:30 p. m., dance orchestra; 7:30, Arcadia cafe concert orchestra.
WMCA, New York, N. Y. (340.7), 8:15-8:25 p. m., talk, House of Health; 11-12, McAlpin hotel orchestra; 12-12:30 a. m., Broadway Bright-Lights.
WNYC, New York, N. Y. (526), 7-7:25 p. m., Chateau Four; 7:25-7:30, baseball results; 7:35-7:45, talk; 7:50-8:30, Chateau Four; 8:30-9, song recitals; 9-9:30, Police quartet; 9:45-10:15, instrumental novelty.
WOO, Philadelphia, Pa. (508.2), 4:45 p. m., organ recital, Mary E. Vogt; 7:30, A. Candelori's concert orchestra.
WOR, Newark, N. J. (405.2), 7:30-8 p. m., the Commanders; 11-12, Citro's orchestra.
WPG, Atlantic City, N. J. (299.8), 6:40 p. m., final announcement winner of National Marble Tournament; 6:45, Arthur Scott Brook, organist; 7, Knickerbocker hotel dinner dance music, Bert Estelow, director; 8:30, special program, Vernon Room, Chalfontie-Haddon

Headliners of the Week

A FEAST of music, features and fun is promised by Station WSAI from 4 p. m. Saturday until 4 a. m. Sunday morning, celebrating this station's second birthday and increase in power to 5,000 watts. All Cincinnati musical organizations will be represented. The Nitecaps on Lake Erie are ready to cruise again this Saturday night, and it promises to be a wild night for the other waxes.

Musicians interested in musical history will enjoy the primitive Russian program given Sunday by Lola Hughes, violinist, and Elfrieda Steindorff, soprano, assisted by the KGO Little Symphony orchestra. Arthur S. Garbett will explain the works of these early Russians.

President Coolidge is honoring the Norse-American Centennial by appearing in person at the Minnesota State Fairgrounds. His talk, which is scheduled for 2:30 p. m. Monday will be broadcast by WCCO. The United States Marine band will play.

Tuesday Lucia de Lammermoor will be presented by the WEAJ Grand Opera company. WEEI, WFI, WCAE, WEAR, WGR and WWJ will

broadcast this performance. Fans who miss the winter opera are enjoying these rare weekly treats. An Indian program illustrating the progress of the Indian in Iowa will be the Tuesday feature at WHO.

A Wampus program composed of thirteen new motion picture beauties will be the feature of the Wednesday program at KFL. Marie Dutton, a comedienne whose joyous stunts are popular in the East, will frolic at WBZ this same evening.

The Seaside hotel trio and the Shelburne hotel concert orchestra will remind fans of sweet breezes and the swell of ocean waves at Atlantic City when they broadcast Thursday at WHAR. CNRM will also subtly remind the complacent fan that there are fascinating lands afar by featuring the White Star-Dominion Line orchestra.

Lovers of old-time songs will enjoy the Emmet Welch's Minstrels Friday at WLIT, Philadelphia. The Manguso family will entertain at WGR this same evening. Little Mary and Mike, whose pictures may be seen on page 11, are only two members of this talented family.

8:40 p. m., baseball results; 8:40-9:30, Lawson Reid, organist.
WAMD, Minneapolis, Minn. (243.8), 9 p. m., open house, light, Twi City entertainers; 10, Amateur night program; 11, George Osborn's Marigold garden orchestra.
WBAP, Ft. Worth, Texas (475.9), 7 p. m., inter-denominational Sunday school lesson, W. F. Barnum.
WCCO, Minneapolis-St. Paul, Minn. (416.4), 6:05 p. m., Dick Long's Nankin cafe orchestra; 8:30, musical program, South Dakota program, Gov. Carl Gunderson; Senator Peter Norbeck; 9, baseball; 10, Dick Long's Nankin cafe orchestra.
WDAF, Kansas City, Mo. (365.6), 6-7 p. m., address, personal message, Roger W. Babson; Trianon ensemble; 11:45-1 a. m., Merry Old Chief, Plantation players; Johnnie Campbell's Kansas City club orchestra.
WFAA, Dallas, Texas (475.9), 6:30-7:30 p. m., Mosley Brothers banjo orchestra; 8:30-9:30, Reuben Davies, pianist; Daisy Polk, singer; 11-12, Adolphus hotel orchestra.
WHAS, Louisville, Ky. (399.8), 8:15 p. m., baseball;

Fred J. Turner is heard every Saturday evening from WBAF, New York, in an interesting series of talks called "Trips and Adventures." Tune in and learn how to become the vagabond of today.



Eastern Standard or Central Daylight Saving Time Stations

KDKA, Pittsburgh, Pa. (309.1), 3:30-7 p. m., baseball scores; 8:45, concert.
KYW, Chicago, Ill. (535.4), 6-6:30 p. m., dinner concert, Congress hotel; 7-8, Mrs. Edna M. Grindon, soprano; Arthur W. Blake, tenor; Henrietta Nolan, violinist; Pearl Fairchild, pianist; 8:35-10:30, Congress classic.
PWX, Havana, Cuba (400), 8:30-11 p. m., studio program.
WBBM, Chicago, Ill. (226), 8-12 midnight, Sandy Meek, Scotch tenor; Lester Kelsey, Paul Small, Tiny Dave Nudleman, Jerry Cromack, Crillon orchestra; Harry Sosnik, pianist; George Little, Larry Shay; Mollie Sisters; Chick Castle.
WCEE, Elgin, Ill. (275), 10:30-12 midnight, Charlene Star dance program, Joe Rudolph and the Boss's own orchestra, Frank Morris, Eddie and Fannie Cavanaugh, Polly Willis, Joan Post.
WCK, Detroit, Mich. (516.9), 4:15 p. m., musical program; 6, dinner concert, Book-Cadillac hotel.
WEAR, Cleveland, Ohio (389.4), 7-8 p. m., novelty dinner concert.
WEBH, Chicago, Ill. (370.2), 7:30-8:30 p. m., Edgewater Beach Hotel Oriole orchestra; 9:30-10:30, Oriole orchestra, Marie Kelly, reader; Kay Kenayne; Langston Dragons; 11:30-1, Oriole orchestra; Loos Brothers; Frank Sylvano, Banks Kennedy, Ned and Ches, Charlie and Gos.
WGES, Oak Park, Ill. (250), 5-7 p. m., Frank Greif, tenor; Bertie Gordon, soprano; Beulah Layden, violinist; Earl Wetland, pianist; 10:30-1, A. Cavallo and his 11 master musicians; Coyne Electrical School serenaders; Ralph Olson, Hal Cowles, pianists; Sandy McTavish, Scotch comedian.
WGN, Chicago, Ill. (370.2), 6:30-7:30 p. m., Drake concert ensemble, Blackstone string quintet; 8:30-9:30, studio program; 10:30-11:30, Drake Hotel Terrace Garden program.
WGY, Schenectady, N. Y. (379.5), 8 p. m., "The Living Age," William Jacob; 8:30, Hotel Van Curler orchestra.
WHT, Deerfield, Ill. (399.8), 7-8:30 p. m., Genevieve B. Burnham, soprano; Bryce Talbot, baritone; Robert Nead, pianist; Al Carney, pianist; 8:45-10:05, (288) Elmer Kaiser's Riverview Park ballroom orchestra; Al Carney, organist; 10:30-1, (399.8) Husk O'Hare's Red Dragons; Al Carney, organist; Walker and Walsworth; duets; Wilkens and Martens; Si Berg, ukulele; Ned Becker, humorist; Lottie Friedman, soprano; Herbie Mintz, pianist; Pat Barnes, reader; John Clark, vocalist; Al Carney, organist.
WJJD, Mooseheart, Ill. (302.8), 10:30 p. m., P. M. Proteau, Golden trio, Sid Erdman, Edward Greaning, violinist; Angelina George, Geneva organ, Charley Straight's orchestra.
WKRC, Cincinnati, Ohio (422), 10 p. m., Zumstein Melody boys; 11, popular program.
WLW, Cincinnati, Ohio (422.3), 7 p. m., WLW dinner hour concert; Johanna Grosse, organist.
WMAQ, Chicago, Ill. (447.5), 6 p. m., Tilden Technical high school glee club; 8, Russell Pratt, Fred Daw; 8:30, Radio photologue, Finland; 9, Chicago theater.
WMBB, Chicago, Ill. (250), 7-8:30 p. m., semi-classical program, J. Bodewalt Lampe; Beatrice Teller and Trianon ensemble; Ambrose Wydek, Edna McFawn, Hazel O'Neil; Armin F. Hand and the Woodlawn theater orchestra; 8:30-10:30, gala syncopation program, Dell Lampe and Trianon orchestra; Seattle Harmony Kings; Fisher and Smith, Harold Stokes, Charles Agne & Trianon syncopators, Florence Tenny, Johnnie Keane, Bob Duffy.

WORD, Batavia, Ill. (275), 8:30 p. m., orchestra music, Golden Age readings.

WJ, Chicago, Ill. (447.5), 7-8 p. m., Ralph Williams and his Rainbo Gardens orchestra; Everett George Orle, reader; Sheppard Levine, tenor; Helen Reed, accompanist; Doris Wall, soprano; Edwina Burchett, alto; 10-3 a. m., Ralph Williams and his Rainbo Gardens orchestra; Jerry Sullivan; Rose Vanderbosch; Melodians; Hickey and Johnson; Bert Davis; Gladys Gale; Henri Thorien, Joe Verger.
WRC, Washington, D. C. (468.8), 7 p. m., Hotel Washington orchestra; 8, Bible talk; 10, Hotel Mayflower orchestra; 10:30, Grandall's Saturday Nighters.
WREO, Lansing, Mich. (285.5), 10-12 midnight, Essenberg's Melody dance orchestra, baseball.
WSAI, Cincinnati, Ohio (325.9), anniversary, program, 4 p. m., WSAI Radio chime concert, Robert Badgley; 4:10, Vox Ferro, solos, Robert S. Alter; 4:25, Mrs. Stella Kent, soprano; Marjorie Bland, accompanist; 4:40, popular songs, Groenke and Mischler; 5, WSAI Radio chimes; 5:15, address, John Onwaka; 5:20, La Verne Sims, soprano; 5:30, Edythe Tolken, violinist; 5:40, John Drury, baritone; 5:50, artist, faculty, Cincinnati Conservatory of Music; 6:20, WSAI story lady, Mrs. Ethel Knapp Behrmann; 6:30, Hotel Sinton concert orchestra; Mrs. Edith Michaux Greene, soprano; 7:30, Elizabeth Durland Langhorst, soprano; 7:45, Lillian Tyler Plogstedt, organist; 8:45, Congress Play- ing Card string quartet; Ruth Heubaeh, soprano; 9:45, Cincinnati College of Music, Lucile Soratino, violinist; Frederick J. Hoffman, pianist; 10, "Radio as an Educator," Dr. Frederick C. Hicks; 10:25, Clifford Lang, pianist; 10:45, Grand hotel instrumental trio; Helene Kessing, soprano; George Clifford Cook, baritone; 11:40, address, Paul A. Greene; 11:50, Bicycle Playing Card sextet; Waldene Reese Johnston, violinist; 12:35 a. m., Lella Lemar, pianist; 12:50, Freda Sanker's Toaststool orchestra; 1:20, popular songs, Bert Lindsay, Kern Alwyard, Billie White; 1:50, Freda Sanker's Toaststool orchestra; 2:40, songs, Conyer, Wintersohl.
WTAM, Cleveland, Ohio (389.4), 6-7 p. m., Hotel Statler concert orchestra; 8-9, studio program; 9-12, Art Herske, Ev Jones and the Coo Coo club; 12 midnight, Nitecaps on Lake Erie; Nitecap Hawaiian quartet; songs, Marie De Ville; Mike Notari and his accompanist; Sweetheart serenaders; Margaret Warner and her ukulele; R. F. Robitoy and Colonial syncopators; songs, Harry Bloom; Original Bessie Brown; Musical Magpies; Case quartet; Carl Rupp and his Hollenden entertainers; Harold McArt, Jack Skillman; Tom Howard and his Melody Lads; Morgan Sisters; Flowery East orchestra; Fred Dempsey; Lucile Phillips, soprano; Zetta Bernhardt, contralto; Austin Wylie and his Golden Pheasant orchestra; Eddie Peabody.
WTAS, Elgin, Ill. (302.8), 8-10:30 p. m., Villa Olivia Radio concert; Joe Rudolph and the Boss's Own orchestra; Eddie and Fannie Cavanaugh; Frank Morris, John Post, Polly Willis.
WTIC, Hartford, Conn. (348.6), 5:55 p. m., baseball scores.
WWJ, Detroit, Mich. (352.7), 3 p. m., Detroit News orchestra.

7:30-9 p. m., Arthur Findling, baritone; baseball.

WLS, Chicago, Ill. (344.6), 8-1 a. m., national barn dance, Ralph Emerson, organist; Tony Corcoran, Margaret Garrity; Sears-Roebuck 4 Aces of Harmony; Williamson Brothers; Harmony Girls; Walter Peterson, WLS Harmony trio; Nubs Allan, contralto; Grace Wilson, contralto.
WMC, Memphis, Tenn. (499.7), 7:30 p. m., baseball; 8:30, program, Elizabeth Hill.
WOAN, Lawrenceburg, Tenn. (282.8), 12:15-12:45 p. m., Vaughan Radio orchestra.
WOAW, Omaha, Nebr. (526), 6 p. m., George Haupt, organist; 6:20, Rialto symphony orchestra; 7, Brandeis School lesson, Dr. Carlton Hull; 8-9, week end revue; 10:45, Journal Hired Help Skykay.
WSMB, New Orleans, La. (319), 6:30-7:30 p. m., dinner music; baseball; 8:30-10:30, concert.

Mountain Standard Time Stations

KOA, Denver, Colo. (322.4), 9-12 midnight, Joe Mann and his Rainbow-Lane orchestra.

Pacific Standard Time Stations

KFI, Los Angeles, Calif. (467), 5:30-6 p. m., Examiner's matinee program; 6-6:15, McDaniels' nightly doings; 6:45-7, radiatorial talk; 7-7:30, vocal pupils, Myra Belle Vickers; 7:30-7:45, Oscar Teel, concert baritone; 7:45, the Bookshelf, Miss Nancy; 8-9, Glendale, Calif. Chamber of Commerce from Examiner studio; 9-10, old folks evening at home, arranged by Glen Rice and Gearard Radio club, Way Watts and his ukulele, Carlson sisters, Dorothy Cleveland and others; 11-3 a. m., KFI midnight frolic, arranged by Don Mean.
KFWB, Hollywood, Calif. (252), 7-8 p. m., Vince Rose's original Hollywood Montmartre cafe dance orchestra; 8-9, program, Monte Mar Vista subdividers; 9-10, popular song hour, Charlie Wellman; Erickson sisters; Frank Stever and others; Warner Brothers syncopators 10-11, Warner Brothers frolic, direction Charlie Wellman.
KGO, Oakland, Calif. (361.2), 8 p. m., Swedish Singing society, Axel Pihlstrom, director; Thorvald Anderson, violinist; Herbert Linden, vocalist; Arthur Weiss, cello ensemble; Virginia Treadwell, contralto; Emil Lichtig, baritone; "The Guy That Delivers the Goods," Thomas A. Boyer; Ethel Isaacs, violinist; Matilda Sross, soprano; 10-1 a. m., Henry Halstead's orchestra.
KGW, Portland, Ore. (491.5), 6-8 p. m., dance music, Jack Souder's orchestra; 10-12, Herman Kenin's Multinomial hotel dance orchestra.
KHJ, Los Angeles, Calif. (405.2), 5:30-6 p. m., Leighton's Arcade cafeteria orchestra, Jack Cronshaw, leader; 6-6:30, Art Hickman's Biltmore hotel concert orchestra, Edward Fitzpatrick, director; 6:30-7:30, little stories American history, Prof. Walter Sylvester Hertzog; Helene Riehl, screen juvenile; Henrietta Poland, readings; Uncle John; Selma Sizer, soprano; Evelyn Potter, pianist; Opal Key, readings; 7:30-8:15, national oratorical contest winners broadcast, Biltmore hotel; 8:15-11, program, Los Angeles Soap company, arranged by J. Howard Johnson, presenting a miniature philharmonic orchestra; 11-11:30, Art Hickman's Biltmore hotel dance orchestra, Earl Burnnett, leader; 11:30-2 a. m., Lost Angeles of KHJ, Majestic Six orchestra.

(Continued on page 9)



Marjorie Moore's Melody Maids are weekly entertainers at WEAR, Cleveland. The girls with their varied programs of classical and jazz numbers have always been popular with WEAR audiences. They are as attractive to look at as they are to listen to.

NITECAPS CRUISE AT WTAM SATURDAY

Saturday, June 6

(Continued from page 8)

KNX, Hollywood, Calif. (336.9), 5:30-6 p. m., Wurlitzer pipe organ studio; sports talk, Sid Ziff; 6:15-6:30, travel talk, W. F. Alder; 6:30-7:30, dinner hour music; 7:30-8, Wurlitzer pipe organ studio; 8-10, KNX feature program; 10-11, Abe Lyman's Coconut Grove dance orchestra; 11-2 a. m., Hollywood screenland night.

KPO, San Francisco, Calif. (428.3), 6:30-7:30 p. m., Johnny Buick's Cabriars; 8-12, Art Weidner's dance orchestra.

Sunday, June 7

Sunday, silent night for: CFAC, CFAC, CKAC, CHIC, CHNC, CNRT, KFAB, KFAE, KFKU, KFKX, KFMQ, KFRU, KFOA, KOB, KSD, PWX, WAHG, WBAV, WCAE, WCEE, WDAF, WDFW, WEAQ, WEBJ, WEBW, WFI, WGBS, WHA, WHAD, WHAS, WHAZ, WIP, WJAD, WLBL, WLIT, WMC, WOI, WOO, WOR, WRC, WSAI, WSMB, WTAM.

Atlantic or Eastern Daylight Saving Time Stations

WBBR, New York, N. Y. (272.6), 10 a. m., Watchtower orchestra; 10:15, Fred Twarosch, tenor; 10:35, Bible lecture, R. H. Barber; 11:15, Fred Twarosch, tenor; 11:15, Watchtower orchestra; 9 p. m., Immanuel choir, instrumental trio, choir.

WZ, Springfield, Mass. (333.3), 9:55 a. m., Church of the Unity, Rev. Charles A. Wing; Philharmonic male quartet; 8, Pierian trio; 8:30, Estye organ company concert.

WCAE, Pittsburgh, Pa. (461.3), 6:30 p. m., dinner concert, William Penn hotel; 7:20, Roxy and his gang.

WCAU, Philadelphia, Pa. (245), 5 p. m., Interdenominational church services, Rev. John W. Stockwell, pastor; Maude Hanson Pettit, musical director; 6 p. m., Hotel Pennsylvania concert orchestra; 7, Hotel Pennsylvania concert orchestra.

WDFW, Providence, R. I. (440.9), 5 p. m., Venetian serenaders, pipe organ recital.

WEAF, New York, N. Y. (491.5), 3-5 p. m., "Sunday Hymn Sing," Federation of churches; 7:20-9:15, Roxy and his gang, Capitol theater; 9:15-10:15, organ recital, W. A. Goldsworthy, St. Andrew's Episcopal church choir.

KDKA, Pittsburgh, Pa. (309.1), 10 a. m., First Church of Christ Scientist; 3 p. m., Dr. Charles Heinroth, organist; 3:45, Shady Side Presbyterian church; 6:30, Calvary Episcopal church.

KYW, Chicago, Ill. (535.4), 10 a. m., Central church service; 3-4 p. m., studio concert.

WBBM, Chicago, Ill. (226), 4-6 p. m., Doney's All Star Jazz orchestra; Harold Winston, tenor; Si Berg, ukulele soloist; Charlie Garland, pianist; Jerry Cromack; 8-10, Sandy Meek, Scotch tenor; Harry Sosnik, pianist; Ned Santry, Crillon orchestra, Lester Kelsey, Si Berg, Tiny Dave Nudelman; 12-1, mid-night nut club frolic, Ralph Atlas, Tiny Dave Nudelman, Charlie Garland, pianist.

WCX, Detroit, Mich. (516.9), 7:15 p. m., services, Central Methodist Episcopal church.

WEBB, Chicago, Ill. (370.2), 7-9 p. m., artists program.

and the Boss's Own orchestra; 8-12, Radio concert, Joe Rudolph and the Boss's Own orchestra; Frank Morris, Polly Willis, Fannie and Eddie Cavanaugh.

Central Standard Time Stations

CKY, Winnipeg, Can. (384.4), 7 p. m., Central Congregational church.

KFAB, Lincoln, Nebr. (240), 4-5 p. m., church service.

KFDM, Beaumont, Tex. (315.6), 11-12 m., program; 8-9 p. m., sacred program.

KFNF, Shenandoah, Ia. (266), 2 p. m., Rev. and Mrs. Hanley, Radio chaplains; 6:30, Golden Rule circle; 8, Christian church.

KFRU, Bristow, Okla. (394.5), 9:30 a. m., Sunday school; 11, sermon; 5 p. m., vesper service.

KFVE, University City, Mo. (240), 6 p. m., Radiocast review, Romaine Fielding; 10, sacred song recital; William Kerr, organist.

WRBC, Valparaiso, Ind. (278), 7:30 p. m., Immanuel Lutheran church services.

WSB, Atlanta, Ga. (428.3), 11 a. m., First Presbyterian church service; 5-6, Sabbath service, Brazelton, Ga., quartet; 7:30, services.

Mountain Standard Time Stations

KOA, Denver, Colo. (322.4), 11:30 a. m., Augustana Lutheran church; 4 p. m., Augustana Lutheran church; 8, Augustana Lutheran church.

Pacific Standard Time Stations

KFI, Los Angeles, Calif. (467), 6:30 p. m., McDaniels' nightly doings; 6:45, musical appreciation talk; 7-8, from stage and studio of Metropolitan theater with 45 piece concert orchestra; 8-9, Sunday classic hour of Italian songs, Neapolitan string trio; 9-10, Examiner, Southwest Athletic club orchestra; 10-11, Theron Bennett's Los Angeles dance orchestra.

KFWB, Hollywood, Calif. (252), 9-11 p. m., Screenland hour, presenting a number of popular players, directors and entertainers.

KGO, Oakland, Calif. (361.2), 11 a. m., First Presbyterian church; 3:30 p. m., KGO Little Symphony orchestra; 7:30, First Presbyterian church.

KGW, Portland, Ore. (491.5), 10:30-12 m., First Presbyterian church; 7:30-9, First Presbyterian church; 9-10, Edwards Dependable coffee concert.

KHJ, Los Angeles, Calif. (405.2), 6-6:30 p. m., Leighton's Arcade cafeteria orchestra, Jack Cronshaw, leader; 6:30-7, Art Hickman's Billmore hotel concert orchestra, Edward Fitzpatrick, director; 7-7:30, organ recital, Arthur Blakey, organist; 8-10:50, surprise program arranged and presented by J. Howard Johnson.

KNX, Hollywood, Calif. (336.9), 7-8 p. m., First Presbyterian Church of Hollywood; 8-9, Ambassador hotel concert orchestra, Josef Rosenfeld, director; 9-10:30, program, Valhalla Mausoleum and Memorial Park.

KPO, San Francisco, Calif. (428.3), 6:35-7:30 p. m., Palace hotel concert orchestra; 8-8:30, Palace hotel concert orchestra; 8:30-10, Rudy Seiger's Fairmont hotel orchestra.

Monday, June 8

Monday, silent night for: AT9, CKAC, CKY, CNRT, KFDM, KFMQ, KFMX, KGW, KHJ, KLDS, KYW, PWX, WAMB, WEBB, WECN, WCAU, WDFW, WEAQ, WEBB, WEBJ, WFI, WGBS, WHAS, WHAZ, WJY, WKAQ, WLS, WMAQ, WMBB, WOC, WOAI, WQJ, WRC, WREO.

Atlantic or Eastern Daylight Saving Time Stations

CHNC, Toronto, Can. (357), 8:30 p. m., CHNC orchestra.

WAHG, Richmond Hill, N. Y. (315.6), 7:30-7:45 p. m., Thornton Fisher, sport talk; 7:45-8, banjo and piano, Harold Von Der Heide and Charles LaRuffa; 8-8:15, Pasquale Ferraro, baritone; 8:15-8:45, Synchronaph string trio; 8:45-9:15, popular songs, Judith Roth; 9:15-9:30, Harold Von Der Heide, Charles LaRuffa; 9:30-10, Synchronaph string trio; 10:15-10:55,



Ethel Sweeney (left) will be the soloist with Theodore J. Irwin, organist, Sunday, June 14, at KPO, San Francisco. Charlotte Nagel (above) is one of the Genevieve's Cave Women who have swooped down upon and conquered WTAM, Cleveland. They will hold sway for the summer. Grace G. Raine is the pianist of the Bicycle Playing Card mixed quartet. She will appear on the special anniversary program this Saturday.

WEEL, Boston, Mass. (476), 7:20 p. m., Roxy and his gang; 9:30, organ recital, Skinner organ.

WFI, Philadelphia, Pa. (394.5), 7:30 p. m., services, Arch street Presbyterian church.

WGBS, New York, N. Y. (315.6), 3:30-4:30 p. m., Piccadilly theater program.

WGR, Buffalo, N. Y. (319), 3-4 p. m., vesper service, Rev. W. H. Beales, New Jerusalem Church of Divine Humanity; 4-5, John W. Newton, organist; 7:45, Central Presbyterian church service, William Wall Whiddit, organist, and Dr. Robert J. MacAlpine, speaker.

WHAR, Atlantic City, N. J. (275), 9 p. m., Seaside hotel trio; 11, Strand theater.

WHN, New York, N. Y. (360), 3-4 p. m., Queens County Christian Endeavor program; 5-5:30, Roseland dance orchestra; 5:30-6, Olcott Vail and his string trio; 10-10:45, Gem Razor entertainers; 10:45-11:15, Janssen's Hofbrau orchestra.

WIP, Philadelphia, Pa. (508.2), 7:15 p. m., services, Holy Trinity church.

WJAR, Providence, R. I. (305.9), 7:20-9:15 p. m., Roxy and his gang; 9:15-10:15, organ recital, New York studio.

WJY, New York, N. Y. (405.2), 8:15-9:15 p. m., Bernhard Levitow's Hotel Commodore orchestra.

WJZ, New York, N. Y. (454.3), 3:30-4 p. m., Chamberlain Women's quartet; 4-4:15, Lillian Seckendorf Popper, pianist; 8-8:15, Max Kalfus, tenor; 9-9:30, Lakewood Farm inn ensemble; 10-10:30, Godfrey Ludlow, violinist.

WKAQ, San Juan, P. R. (340.7), 8-10 p. m., Municipal cafe concert orchestra.

WLIT, Philadelphia, Pa. (394.5), 2:15 p. m., Arcadia cafe concert orchestra.

WMCA, New York, N. Y. (340.7), 11-12:15 p. m., services, Christian Science church; 7-7:30, Ernie Golden and his Hotel McAlpin orchestra; 7:30-7:55, House of Health talk.

WNYC, New York, N. Y. (526), 4-5:30 p. m., band concert, Mall, Central Park; 9-11, Brooklyn Mark Strand theater program.

WOOD, Philadelphia, Pa. (508.2), 10:15 a. m., services, Bethany temple; 2:15 p. m., Sunday school services, Bethany temple; 6-6:05, organ recital, sacred music, Clarence K. Bawden.

Eastern Standard or Central Daylight Saving Time Stations

AT9, Fort Bragg, N. C. (435), 6:45-7:45 p. m., concert, Fifth Field Artillery band.

WGN, Chicago, Ill. (370.2), 11:45 a. m., program, Chicago theater; 3:30 p. m., faculty, Chicago Musical college; 9-10, Drake concert ensemble.

WGY, Schenectady, N. Y. (379.5), 9:30 a. m., First Presbyterian church services; 6:30 p. m., evening services, First Presbyterian church; baccalaureate sermon, Dr. Charles Richmond; 7:45 p. m., Hotel Commodore orchestra; Bernard Levitow, conductor.

WHT, Deerfield, Ill. (238), 9-11:30 p. m., Paul Rader.

WIBO, Chicago, Ill. (226), 10:15 a. m., Edgewater Presbyterian church services, Rev. Asa J. Ferry; Jorwerth W. Prosser, organist; quartet; 2-4 p. m., choir; Dan Russo and Ted Fiorito; Morris Kowalski, pianist; 6-8, Hineshaw Conservatory of Music program; 10-12, Vic Lehman, tenor; Carl Linner, pianist; Dan Russo and Ted Fiorito.

WJJD, Mooseheart, Ill. (302.8), 12 midnight, Lillian Bernard, Flo Henry, Dick Vail, Les Cameron, Walter Pett, Charley Straight's orchestra.

WKRC, Cincinnati, Ohio (422.3), 6:45 p. m., Walnut Hillis Christian church; 10, classical program.

WLW, Cincinnati, Ohio (422.3), 9:30 a. m., school, editorial staff of Sunday school publications, Methodist Book concern, Church of Covenant, Dr. Frank Stevenson; 7:30 p. m., service, First Presbyterian Church of Walnut Hills; Dr. Frederick McMillan; 8:30, Westminster and Southern orchestra, William Kopp, director; George Muhlhauser, tenor.

WMBB, Chicago, Ill. (250), 3-5 p. m., Sunday popular concert, Dell Lampe and Trioan orchestra; Trioan synopators; Ambrose Wyrick, Hazel O'Neil; Lindsey McPhail; Clyde Hager; 7-8:30, semi-classical program, J. Bodewalt Lampe; Beatrice Teller and Trioan ensemble; Ambrose Wyrick, Rita McFawn, Hazel O'Neil, Armin F. Hand and Woodlawn theater orchestra; 8:30-10:30, Dell Lampe and Trioan orchestra, Seattle Harmony Kings; Alvin Fry, Geraldine Doyle, Morey Alswang, Armin F. Hand and the Woodlawn theater orchestra.

WQJ, Chicago, Ill. (447.5), 8-10 p. m., Rainbo Garden orchestra; Grace Nelson, pianist; Alice Johnstone, pianist; Gloria Burch, violinist; Juanita Swenk, soprano; Oscar Williamson, tenor; Harry Abernathy, accompanist; Vincent Gullotta, violinist.

WREO, Lansing, Mich. (285.5), 10-10:25 a. m., chimes, Belfry Plymouth Congregational church, Rev. Edwin W. Bishop, pastor; 7:30, Central M. E. church, Rev. Frank Kingdon, pastor.

WSAI, Cincinnati, Ohio (326), 3 p. m., sermonette, sacred chimes.

WTAS, Elgin, Ill. (302.8), 2-5 p. m., Joe Rudolph

KLDS, Independence, Mo. (268), 11 a. m., studio service; Aileen Reich, soprano; S. A. Burgess, contralto; Marian Campbell, contralto; A. B. Moler, tenor; A. B. Church, bass; sermonette, U. Green; 6:30 p. m., vesper service; sacred music; Robert Miller, organist; lectures.

KTSS, Hot Springs National Park, Ark. (374.3), 11 a. m., First Presbyterian church; Frances Hardin, organist; 8:30-9:15, New Arlington Hotel Meyer Davis orchestra; 9:15, baseball; 9:25-10, New Arlington hotel orchestra; 10-11:30, Chuck Root's De Soto garden orchestra.

WBAP, Ft. Worth, Tex. (47.9), 11 p. m., frolic, Knickerbocker Buddies.

WCBD, Zion, Ill. (344.6), 8 p. m., male quartet, Mrs. Thomas, Mr. Barton, Mr. and Mrs. Richard E. Hire, violin duets; Mrs. J. D. Thomas, soprano; Daniel Mason, trombonist; Gerald Mason, cornetist; Carl Newcomer, marimba soloist; Mrs. Hire, Mrs. Ower, pianists; Mrs. Hester Robinson, reader.

WCOO, Minneapolis-St. Paul, Minn. (416.4), 10:20 a. m., Plymouth Congregational church; 4:10 p. m., House of Hope Presbyterian church; 7:20, Second Church of Christ Scientist; 9:15, Norse-American Centennial program.

WDAF, Kansas City, Mo. (365.6), 4-5 p. m., classical music; 5-5:30, Sunday school lesson, Dr. Walter L. Wilson.

WEBW, Beloit, Wis. (268), 4:25-5:30 p. m., Sunday vespers.

WFAA, Dallas, Tex. (475.9), 6:30-7:30 p. m., Radio Bible class; Dr. William M. Anderson; 8-9, First Baptist church; 9:30-11, Buddy's Blue Melody boys.

WHAS, Louisville, Ky. (399.8), 9:57 a. m., organ music; 10, Fourth Avenue Presbyterian church; 4-5, concert, Ella Sharrard, director.

WHO, Des Moines, Ia. (526), 11 a. m., University Church of Christ; 4 p. m., program, Dean Holmes Cowper; 7:30, Reese-Hughes orchestra.

WLS, Chicago, Ill. (344.6), 6:30-7:30 p. m., Ralph Emerson, organist; 7-8, WLS Little Brown church.

WOAN, Lawrenceburg, Tenn. (282.8), 9-10 p. m., sacred orchestra, male quartet.

WOAW, Omaha, Nebr. (256), 9 a. m., Radio chapel service, Rev. R. R. Brown; 9, Florence Presbyterian church.

WOC, Davenport, Ia. (483.6), 8-8:30 p. m., Trinity Episcopal Cathedral, Rev. Rodney Cobb; 9:30-11:30, Palmer Little symphony, Erwin Swindell, conductor.

WOI, Ames, Ia. (270), 10:45 a. m., college chimes; 11, chapel services.

Kentucky Ramblers; 11:15-11:30, Kentucky Ramblers.

WBBR, New York, N. Y. (272.6), 8 p. m., Syrian Oriental music, Toufic Moubald, Elizabeth Awad; 8:10, vocal selections; 8:35, "Harp of God," Bible instruction; 8:45, vocal selections, Syrian Oriental music.

WBZ, Springfield, Mass. (333.3), 6 p. m., Capital theater orchestra; 8, William Kempf, violinist; 8:45, E. H. Bond, baritone; 9, Florence Shortleeve Fay, violinist; Myrtle I. Ashe, pianist; Fabiola D. Richardson, soprano; 9:30, "At the Theaters," A. L. S. Wood; 9:45, baseball.

WCAE, Pittsburgh, Pa. (461.3), 6:30 p. m., dinner concert, William Penn hotel; 8, address, auspices Pittsburg Personnel association; 8:30, concert; 11, flight of mythical dirigible, Press-Kaybee.

WEAF, New York, N. Y. (491.5), 6-7 p. m., dinner music, Waldorf-Astoria; 7-7:15, talk, Parks Conservancy association; 7:15-8:50, program, Mark Strand theatre and studio, direction of Joseph Plunkett; 8:30-8:45, Bordentown Industrial School male quartette; 8:45-9, health talk, Metropolitan Life Insurance company; 9-10, A. and P. Gypsies; 10-10:30, Blue Ribbon quartette; 10:30-11:30, Ben Bernie's Hotel Roosevelt orchestra.

WEEL, Boston, Mass. (476), 5:30 p. m., Jack Brown and his Chauve Souris orchestra; 6:30, Big Brother club; 7:15, musicale; 8, musicale; 8:45, Tower Health talk; 9, A. & P. Gypsies; 10, Blue Ribbon quartet.

WFI, Philadelphia, Pa. (394.5), 3 p. m., Lillian Orliner, soprano; Loretta Kerk, pianist; Reith McMullin, impersonations; 6:30, Bellevue Stratford concert orchestra; 7, bedtime stories.

WGBS, New York, N. Y. (315.6), 6-6:30 p. m., Uncle Geebee; 6:30-7:30, Lew Krueger's dance orchestra.

WGR, Buffalo, N. Y. (319), 2:30-4:30 p. m., WGR's afternoon program, A. J. Erlman, director; 6-7, Rush Yates and his Terrace orchestra, of Hamilton, Ont.; 9-10, program, Choral Club of Buffalo; 10-10:30, violin, voice and piano recital; 11-1 a. m., supper-dance music, Vincent Lopez Hotel Statler dance orchestra, Harold Glesser, director.

WHAR, Atlantic City, N. J. (275), 7:30 p. m., Seaside hotel trio; 9, Shelburne hotel concert orchestra.

WHN, New York, N. Y. (360), 6:30-7 p. m., Palais D'Or orchestra; 7:30-7:35, health talk, Dr. Landis; 8-8:15, talk, "Storage Batteries," H. B. Shontz; 8:15-8:35, Roseland dance orchestra; 8:35-8:40, talk, H. W. Carlogh of Terminal Barber Shops; 8:50-9:20, Littmann's Empires orchestra; 9:30-10, Clover Gar-

(Continued on page 10)

WAMPUS BEAUTIES HEARD AT KFI

Monday, June 8

(Continued from page 9)

dens Entertainment; 11:30-12, organ recital, Loew's Lexington theatre; 11:30-12, Silver Slipper revue and orchestra.

WIP, Philadelphia, Pa. (508.2), 4:15 p. m., garden talk, Chas. K. Hallowell; 6:05, Clarence Seamon's concert orchestra; 7, Uncle Wip's bedtime stories; "Control of Tuberculosis," Dr. Ward Brinton.

WJAR, Providence, R. I. (305.9), 8 p. m., dance music; 9, A. & P. Gypsy string ensemble.

WJZ, New York, N. Y. (454.3), 7-8 p. m., Bernhard Levitow's Hotel Commodore dinner concert; 8-8:10, Wall Street Journal review; 8:10-8:30, NYU Air college; 8:30-9:30, program, Landay Hall; 9:30-9:45, duets, Marie Nicholson, soprano; Elizabeth Gibbs, contralto.

WLIT, Philadelphia, Pa. (394.5), 4:30 p. m., Magazine corner, Mrs. B. F. Maschal; Marcella North, pianist; 7:30, Dream Daddy's bedtime stories; 8:30, concert, Hayden club; 9:30, concert from Stanley theater; 10, Arcadia cafe dance orchestra; Spike Hamilton's Barbary Coast orchestra direct from Young's Million Dollar Pier, Atlantic city.

WMCA, New York, N. Y. (340.7), 4-5 p. m., Paul "Alcure" Laurel House trio; 6:30-7:30, Ernie Golden and his Hotel McAlpin orchestra; 8-9, joint recital, Edward French, pianist; Herman Weinstein, violinist; 9:25-9:30, health talk; 10-10:30, McAlpin Radio Forum; 10:30-11, George Kohlmeier orchestra; 11:30-12, George Kohlmeier orchestra.

WNYC, New York, N. Y. (526), 7-7:25, Original Charleston Five; 7:25-7:30, baseball results; 7:35-7:40, health talk; 7:50-8, piano recital; 8-8:15, "Knotty Problems in Baseball," John B. Foster; 8:15-9:30, concert program; 10-10:30, Harry Ash's orchestra.

WOO, Philadelphia, Pa. (508.2), 4:45 p. m., organ recital, Mary E. Vogt; 7:30, Hotel Adelphia Roof Garden orchestra; 8, Mark Strand theater concert; 8:30, A. and P. Gypsies; 10:03, organ recital, Marie E. Vogt; 10:30, Vincent Bizzio's dance orchestra.

WOR, Newark, N. J. (405.2), 6:15-7:15 p. m., Ernie Krickett's orchestra; 7:15-7:25, sport talk; 8:30-9:30, Al Reid's hour; 9:30-10:30, Dr. Sigmund Spaeth's party; 10:45-11, two-man singing orchestra, Perry and Russell; 11:30-12, The Commanders.

Eastern Standard or Central Daylight Saving Time Stations

KDKA, Pittsburgh, Pa. (309.1), 2:30-7 p. m., baseball scores; 8:45, concert.

WBAV, Columbus (293.7), 8 p. m., WBAV orchestra.

WBMM, Chicago, Ill. (226), 6-7 p. m., Carlton orchestra.

WCEB, Elgin, Ill. (275), 10:30-12 midnight, Joe Rudolph and the Boss's own orchestra; Frank Morris, Polly Willis, Eddie and Pannie Cavanaugh; John Post.

WCX, Detroit, Mich. (516.9), 4:15 p. m., musical program; 6, dinner concert, Book-Cadillac hotel; 7, musical program.

WEAR, Cleveland, O. (389.4), 7-8 p. m., musical program, Loew's State theater.

WGN, Chicago, Ill. (370.2), 6:30-7 p. m., Drake concert ensemble, Blackstone string quintet.

WGY, Schenectady, N. Y. (379.5), 1 p. m., music, talk; 5:30, Hotel Ten Eyck orchestra; 6:15, "Home Canning," Prof. Lucille Brewer; 6:35, Spark's Circus program; band concert; 500 voice chorus; Mlle. Duval, vocalist.

WHT, Deerfield, Ill. (399.8), 7-8:30 p. m., Evelyn Elmhurst, harpist; Robert Nead, pianist; Seola Aikman, soprano; Adele Brandt, contralto; Al Carney, organist; 8:45-10:05 (233), Elmer Kaiser Riverview Park Ballroom orchestra; 10:30-11 (399.8), David Boyd, whistler; Walter Donovan, tenor; Carl Stockenberg, harmonica soloist; Brock Sisters; Alvin Fry, tenor; Milton Grossman, saxophonist; Heather and Stephenson; Al Carney, Husk O'Hare's orchestra; Northland trio.

WJJD, Mooseheart, Ill. (302.8), 10:30 p. m., Cantor A. Kritz, George LaFebre, J. I. Shuffittowski, Reneau Sisters, William Horowitz, Geneva organ, Charley Straight's orchestra, May Ward.

WKRC, Cincinnati, Ohio (422.3), 10 p. m., Benzol entertainers; 11, popular program; 12, midnight program, Kodel gang.

WLW, Cincinnati, Ohio (422.3), 7 p. m., dinner hour concert, Hotel Gibson; Hotel Gibson concert, Robert Visconti, director; 8:15, entertainment, Cincinnati Zoo; 9:15, violin and piano solo, Patricia and Margaret Conway; 9:30, Davis Reflectograph concert; Famous Lyric male quartet.

WMAQ, Chicago, Ill. (447.5), 2:45 p. m., Cuba-New York baseball; 6, Chicago theater organ recital; 6:30, Hotel LaSalle orchestra; 6:50, Family Altar league.

WRC, Washington, D. C. (468.5), 5-6:30 p. m., U. S. Navy band.

WREO, Lansing, Mich. (285.5), 10 p. m., baseball.

WSAI, Cincinnati, Ohio (326), 10 p. m., Apollo mixed quartet.

WTAM, Cleveland, Ohio (389.4), 6-7 p. m., Golden Pheasant studio dance music; 8-9, Willard studio instrumental hour, Willard symphony; Walter Logan, director; 9-11, Willard symphony and artists, excerpts from "Aida"; 11-12, Public auditorium organ recital; Edwin Arthur Kraft, organist.

WTAS, Elgin, Ill. (302.8), 8-10:30 p. m., Villa Olivia Radio concert, Joe Rudolph, orchestra; Eddie and Pannie Cavanaugh, Frank Morris, Polly Willis, John Post.

WTIC, Hartford, Conn. (348.6), 6 p. m., Hotel Bond trio, Lois Randall, soprano; 6:50, baseball scores; 7, dinner music.

WWJ, Detroit, Mich. (352.7), 6 p. m., dinner concert; 8, concert from New York; 9, Detroit News orchestra.

Central Standard Time Stations

KFAB, Lincoln, Neb. (240), 7:30-9:30 p. m., Waikiki trio; Colmans orchestra, Orville Andrews, Buick Warbler; Charles Kokesch, pianist.

KFKU, Lawrence, Kan. (275), 7 p. m., music; 7:15, "The Story of Sand and Gravel Deposits," Prof. R. S. Knappen; 7:30, "Some Recent Biography and Autobiography," Prof. R. D. O'Leary; 7:45, Spanish lesson.

KFMF, Shenandoah, Ia. (266), 7:30 p. m., concert, Healy Field, Seed company.

KFRU, Bristow, Okla. (394.5), 7-8 p. m., Oklahoma Educational hour; 8-10:30, entertainment.

KFVE, University City, Mo. (240), 6 p. m., Radioeast review, Romaine Fielding; 10, male quartet, T. G. Cosby, director.

KSD, St. Louis, Mo. (545.1), 9 p. m., Gardner Motor company Eight-in-Line entertainers; 10, American Legion band of Belleville.

KTHS, Hot Springs National Park, Ark. (374.8), 8:30-8:40 p. m., baseball; 8:30-9, New Arlington hotel orchestra; 9-10, concert, Alice C. Henniger, director.

WBAF, Ft. Worth, Tex. (475.9), 7:30-8:30 p. m., mixed program, North Texas Traction company; 9:30-10:45, popular music, Ward's "Trail Blazers"; 11-12, George C. Orum's Palace theater orchestra.

WCBD, Zion, Ill. (344.6), 8 p. m., concert quartet, Celestial bells; instrumental trio; Fred Faassen, organist; Alexander DePew, flutist; Mrs. H. E. Mayfield, soprano; Lillian Detienne, reader.

WCCO, Minneapolis-St. Paul, Minn. (416.4), 2:30 p. m., address, President Coolidge at the Norse-American Centennial; 4, baseball; 4:05, Readers' club; 5:30, children's hour; 6, baseball; 6:45, E. & R. Family; 8, opening program; 9, baseball.

Baseball Scores

TABULATED below is a time table of the stations giving baseball scores this week. Stations are divided into the different standard times in use. The hours are given in the kind of time in use at each listed station:

Atlantic or Eastern Daylight Saving Time Stations

Saturday, June 6: 4:30, WJZ; 5:45, WTIC; 5:30, WJZ; 7:25, WNYC; 8, WJZ.

Monday, June 8: 7:25, WNYC; 9:50, WBZ.

Tuesday, June 9: 7:25, WNYC; 9:50, WBZ.

Wednesday, June 10: 7:25, WNYC; 9:50, WBZ.

Thursday, June 11: 7:25, WNYC; 9:50, WBZ.

Friday, June 12: 7:25, WNYC; 9:50, WBZ.

Eastern Standard or Central Daylight Saving Time Stations

Saturday, June 6: 2, WGY; 2:30, KDKA; 2:45, KDKA, WMAQ; 2:30, KDKA; 3, KDKA; 3:15, KDKA; 3:30, KDKA; 3:55, WWJ; 4, WMAQ; 4:15, 4:30, 4:45, 5, KDKA; 5:55, WTIC; 6, WGN, WLS; 6:50, WTIC; 7, KDKA; 9:55, KDKA; 10, WREO.

Sunday, June 7: 6:55, WTIC.

Monday, June 8: 2, WRC; 2:45, WMAQ; 3:30, KDKA; 3:45, WEAR; 3:55, WWJ; 4, KDKA, WMAQ; 4:30, 5, KDKA; 5:55, WTIC; 6, WGN, WLS; 6:50, WTIC; 9:55, KDKA; 10, WREO.

Tuesday, June 9: 2, WRC; 2:45, WMAQ; 3:30, KDKA; 3:45, WEAR; 3:55, WWJ; 4, WMAQ; 4:30, 5, 7, KDKA; 6, WGN, WLS; 9:55, KDKA; 10, WREO.

Wednesday, June 10: 2, WRC; 2:45, WMAQ; 3:30, KDKA; 3:45, WEAR; 3:55, WWJ; 4, 4:30, 5, WWJ; 6, WGN, WLS; 6:50, WTIC; 7, KDKA; 9:55, KDKA; 10, WREO.

Thursday, June 11: 2, WRC; 2:45, WMAQ; 3:30, KDKA; 3:45, WEAR; 3:55, WWJ; 4, 4:30, 5, KDKA; 6, WGN, WLS; 6:50, WTIC; 9:55, KDKA; 10, WREO.

Friday, June 12: 2:30, KDKA; 2:45, WMAQ; 3:30, KDKA; 3:45, WEAR; 3:55, WWJ; 4, WMAQ; 4:30, 5, KDKA; 6, WGN, WLS; 6:50, WTIC; 9:55, KDKA; 10, KREO.

Mountain Standard Time Stations

KOA, Denver, Colo. (322.4), 8 p. m., Fred Schmitt and his Riado theater orchestra; 8:10, St. Anne Dramatic club, "The Allen Princess"; "Romeo and Juliet," KOA players; KOA orchestra.

Pacific Standard Time Stations

KFAE, Pullman, Wash. (348.6), 7:30-9 p. m., Theta Upsilon national sorority; Katherine Conner, cellist; Florence Lester, vocalist; Claribel Conner, Ruth Coates, violinists; Bernice Hamilton, reader; Donna Whitney, pianist; Florence Lester, Dorothy Hutchison, vocalists; Spokane string trio; Tau Nu Kappa Boilermakers; "Care of Pet Animals," Dean E. E. Wenger; "Home Management at the Farm Women's Camp," Gladys Gallup; "How to Engage in Farming with Limited Capital," George Severance.

KFI, Los Angeles, Calif. (467), 5:30-6 p. m., Examiner's matinee musicale; 6-6:15, McDaniels' nightly

Central Standard Time Stations

Saturday, June 6: 3:15, WHAS; 3:30, WDAF; 4:30, WDAF, WFAA; 5, WDAF; 6, WCCO, WDAF, WOC; 6:30, WSMB; 8:30, KTHS.

Sunday, June 7: 4:30, WFAA; 6:45, WOC; 9, WCCO; 9:15, KTHS.

Monday, June 8: 3:15, WHAS; 3:30, WDAF; 4, WCCO, WDAF; 4:30, WFAA; 5, WDAF; 6, WCCO, WDAF; 6:30, WSMB; 8:30, KTHS; 9, WCCO.

Tuesday, June 9: 3:15, WHAS; 3:30, WDAF; 4, WCCO, WDAF; 4:30, WFAA; 5, WDAF; 6, WCCO, WOC; 6:20, WQAW; 6:30, WSMB; 8:30, KTHS; 9, WCCO.

Wednesday, June 10: 3:15, WHAS; 3:30, WDAF; 4, WCCO; 4:30, WDAF, WFAA; 5, WDAF; 6, WCCO, WDAF, WOC; 6:30, WSMB; 8:30, KTHS; 9, WCCO.

Thursday, June 11: 3, WDAF; 3:15, WHAS; 4, WCCO, WDAF; 4:30, WFAA; 5, WDAF; 6, WCCO, WDAF, WOC; 6:20, WQAW; 6:30, WSMB; 8:30, KTHS, WCCO.

Friday, June 12: 3, WDAF; 3:15, WHAS; 4, WCCO, WDAF; 4:30, WFAA; 6, WCCO, WDAF, WOC; 6:20, WQAW; 6:30, WSMB; 8:30, KTHS; 9, WCCO.

Mountain Standard Time Stations

Monday, June 8: 6, KOA.

Tuesday, June 9: 6:30, KOA.

Wednesday, June 10: 6, KOA.

Thursday, June 11: 6, KOA.

Friday, June 12: 6, KOA.

Pacific Standard Time Stations

Saturday, June 6: 6, KFOA; 6:45, KGO; 7:30, KGW.

Monday, June 8: 6, KFOA; 6:45, KGO; 7:30, KGW.

Tuesday, June 9: 6, KFOA; 6:45, KGO; 7:30, KGW.

Wednesday, June 10: 2, 3, 4, KNX; 6, KFOA; 6:45, KGO; 7:30, KGW.

Thursday, June 11: 6, KFOA; 6:45, KGO; 7:30, KGW.

Friday, June 12: 2, 3, 4, KNX; 6, KFOA; 6:45, KGO; 7:30, KGW.

WDAF, Kansas City, Mo. (365.6), 6-7 p. m., piano tuning-in number; Cecile Burton, reader; Plantation players; 9-10, around the town with WDAF; 11:45-1 a. m., Merry Old Chief, Plantation players; Charles Dornberger's Kansas City Athletic club orchestra.

WEBW, Beloit, Wis. (268), 8:30-9:45 p. m., men's glee club.

WFAA, Dallas, Texas (475.9), 6:30-7:30 p. m., Roy Leffingwell's orchestra; 8:30-9:30, Sweetwater violin choir, Miss O. L. Cutbirth, director.

WHA, Madison, Wis. (535.4), 7:45 p. m., University School of Music; "Logic and Life," Prof. M. C. Otto.

WHAS, Louisville, Ky. (399.8), 3:15 p. m., baseball.

WHO, Des Moines, Ia. (526), 7:30-8 p. m., Mary Mack, popular soloist; Katherine Torey, pianist; 8-9, program, Dean Holmes Cowper, director; 11:15-12, organ recital.

WMC, Memphis, Tenn. (499.7), 8:30 p. m., Washington Syncopters.

WOAN, Lawrenceburg, Tenn. (282.8), 12:15-12:45 p. m., orchestra; 9-10, orchestra, male quartets.

WOAW, Omaha, Neb. (526), 6 p. m., Phyllis Griswold, organist; 6:30, McCroxy's popular period, Lillian Madison, director; 6:45, orchestra; 9, program, Hannan-Van Brunt company, Ford dealers.

WOI, Ames, Ia. (270), 10 p. m., program of popular music.

WRBC, Valparaiso, Ind. (278), 7:30 p. m., music and speakers.

WSB, Atlanta, Ga. (428.3), 5-6 p. m., bedtime story, Bonnie Barnhardt; Georgian's orchestra; 8-9, music; 10:45, Warner's Seven Aces.

WSMB, New Orleans, La. (319), 6:30-7:30 p. m., dinner musicale, baseball, twilight tales; 8:30-10:30, Leslie George and his Patio Royal dance orchestra, Fuzzy-Wuzzy Twins.

doings; 6:45-7, editorial talk; 7-8, California Serenaders dance orchestra, direction George Cronk; Sigmund Cachs, violin soloist; Rolfe Pratt, tenor; 8-9, songs of the old south with interesting bits about who wrote them; 9-10, program, Walter M. Murphy Motors company; Virginia Plohri, the Radio nightingale; Los Angeles string quartet; J. Roy Logge, baritone; 10-11, Examiner, Ray West and his Alexandria hotel dance orchestra.

KFWB, Hollywood, Calif. (252), 6:30-8 p. m., program, John A. Evans corporation, Hacienda Park dance orchestra; 8-9, program, Cheek-Neal Coffee company, Maxwell House coffee string quartet, Harry Jackson, leader; Bill Hatch and Ray Kellogg, the jazz twins; 9-10, Sereandand dance orchestra; 10-11, Warner Brothers' frolic, direction Charlie Wellman.

KGO, Oakland, Calif. (361.2), 8 p. m., educational program; Amphion trio; "Drainage of Farm Land," Prof. W. V. Weir; "Class Room Instruction by Radio," Dr. Virgil E. Dickson; "To Think Without Confusion," John Snape; "Editorial Arrows," Charles K. Field; 10-1, Henry Halstead's orchestra.

KGW, Portland, Ore. (491.5), 6-7 p. m., Frederick W. Goodrich, organist; 7:30-8, baseball.

KNX, Hollywood, Calif. (336.9), 5:30-6 p. m., Wuriltzer pipe organ studio; Sid Ziff's sports talk; 6:15-6:30, travel talk, W. F. Alder; 6:30-7:30, dinner hour program, Detmers Optical company; 7:30-8, program, Columbia Outfitting company; 8-9, KNX feature hour; 9-10, program, L. W. Stockwell company; 10-11, Goodrich Silvertown Cord orchestra, June Pursell, soloist; 11-12, Abe Lyman's Cooconut Grove dance orchestra, from Ambassador hotel.

KPO, San Francisco, Calif. (428.3), 6:15-6:30 p. m., baseball; 6:40-7:30, States Restaurant orchestra; 8-9, talk, Joseph D. Redding; American composer; Theodore J. Irwin, organist; 9-10, Studio program; 10-11, States Restaurant orchestra.

Tuesday, June 9

Tuesday, silent night for: AT9, CFCA, CHNC, CHIC, CHYC, CNRT, KFAE, KFKU, KFKX, KFNF, KJR, KLX, KOA, KOB, PWX, WAHG, WBAV, WBBR, WOB, WEAO, WHA, WHAD, WHAZ, WKQA, WOI, WOS, WRBC, WTAM.

Atlantic or Eastern Daylight Saving Time Stations

CKAC, Montreal, Can. (410), 7 p. m., talks on hygiene; 7:30, Windsor hotel dinner concert; 8:30, Montreal Press club entertainers; 10:30, Windsor Hotel Cascade room dance orchestra.

CNRA, Moncton, Can. (313), 8:30 p. m., Jewish concert, Y. M. H. S. of Saint John; CNRA orchestra.

WAHG, Richmond Hill, N. Y. (315.6), 12:30-1:15 p. m., music, time signals and weather reports.

WBZ, Springfield, Mass. (333.3), 6 p. m., Leo Reisman Hotel Lenox ensemble; 8:15, Andre Savard, pianist; 8:30, Old Timers' program; Katherine White, soprano; Bay State quartet; Patrick J. Gafney, fiddler; Blanche Pickering, pianist; 9, Hotel Brunswick orchestra; 9:50, baseball.

WCAE, Pittsburgh, Pa. (461.3), 6:30 p. m., dinner concert, William Penn hotel; 8, program from New York; 8:30, Gold Dust Twins; 9, Eveready hour; 10, Grand Opera.

WCAU, Philadelphia, Pa. (245), 6 p. m., Hotel Pennsylvania fraternitery orchestra; 6:30, Charles Verna's dance orchestra; 7:30, concert, N. Snellenburg & Co.; 8, talk, Clara Zillesen; 9:15, "What I've Seen and Heard in Music," Maude Hanson Pettit; 10:30, Charles Verna's dance orchestra.

WDWF, Providence, R. I. (440.9), 8:30 p. m., Arcadia orchestra.

WEAF, New York, N. Y. (491.5), 6-7 p. m., dinner musical, Waldorf-Astoria; 7-7:10, William J. Fagan, baritone; 7:10-7:30, Columbia University lecture; 7:30-8, Eagle Neurodyne trio; 8-8:10, talk, Bank of America; 8:10-8:30, talk, "Why Worry," Bishop Phillip Cook of Episcopal Diocese of Delaware; 8:30-9, Gold Dust Twins; 9-10, Eveready hour; 10-11, grand opera, "Lucia di Lammermoor," WEAF Grand Opera company; 11-12, dance program.

WEBJ, New York, N. Y. (233), 7-7:30 p. m., Bert Roborn's orchestra; 7:45-8, Thomas Prytheick, tenor; Mildred Mayes, pianist; 8-8:10, railroad talk, G. T. Geer; 8:15-8:30, Sara V. Turits, soprano; 8:30-9, Ken Burdick, baritone.

WEEL, Boston, Mass. (476), 6:30 p. m., Big Brother club; 7:15, musicale; 8, musicale from New York; 8:30, Gold Dust Twins; 9, Eveready hour; 10, Grand Opera company.

WFI, Philadelphia, Pa. (394.5), 3 p. m., talk, "Bringing the Bank Closer to the Public"; 6:30, Bellevue Stratford concert orchestra; 7, Radio Scout; 8, concert from WEAF; 8:30, Gold Dust Twins; 9, Eveready hour.

WGBS, New York, N. Y. (315.6), Crete Carton, soprano; 6-6:30 p. m., Uncle Geebee; 6:30-7:30, Jersey Collegians; 8:30, Ellen Jane Thompson, soprano; 9-10, Y. M. C. A. musical program; Charles S. Lewis, pianist; Charles W. Schroter, tenor; 10-10:30, May Singh Breen and Peter de Rose; 10:30-10:40, interview with Paul Whiteman, Terese Rose Nagel; 10:40-11, Paul Ross, violinist; 11-11:30, Samuel Shangkman, pianist.

WGR, Buffalo, N. Y. (319), 2:30-4:30 p. m., WGR's afternoon program, A. J. Erisman, director; 8-11, joint broadcast with WEAF, including William S. Lewin, baritone soloist; address, Bishop Phillip Cook of "Why Worry"; Gold Dust Twins, Eveready hour, and operatic selections, "Lucia de Lammermoor."

WHAR, Atlantic City, N. J. (275), 7:30 p. m., Seaside hotel trio; 9, Hotel Shelburne concert orchestra; 11, Strand theater.

WHN, New York, N. Y. (360), 7-7:30 p. m., Colonial Aces; 7:30-7:35, health talk, Dr. Lands; 9:30-10, Palisades Amusement Park orchestra; 11:30-12, Club Alabam orchestra; 12-12:30 a. m., Parody club revue and orchestra.

WIP, Philadelphia, Pa. (508.2), 6:05 p. m., Benjamin Franklin concert orchestra; 7, Uncle Wip's bedtime stories; 8, St. Alban's Glee club assisted by Girard Craftsmen male quartet; 9, piano recital, Florine R. Thabauter; 9:30, talk, Harry Weir, city architect, Wildwood, N. J.; 10:05, movie talk, Eli M. Orowitz; 10:30, Howard Lanin's dance orchestra.

WJAR, Providence, R. I. (305.9), 8:30 p. m., Gold Dust Twins; 9, Eveready hour.

WJY, New York, N. Y. (405.2), 8:15-8:30 p. m., talk, "The Birds of Paradise," Lee S. Crandall of Zoological society; 8:30-8:45, George Dale, tenor; Horne Neely, accompanist; 8:50-9, Jefferson Memorial talk, Pauline Henkle.

WJZ, New York, N. Y. (454.3), 7-7:15 p. m., Frank Dole's dog talk; 7:15-8, Joseph Striffo's Hotel Vanderbilt orchestra; 8-8:10, Wall Street Journal review; 8:10-9:10, Wanamaker program; 9:30-9:45, A. Duques, clarinetist.

WLIT, Philadelphia, Pa. (394.5), 2:30 p. m., "Care of Children," Mrs. Louis Love; 7:30, Dream Daddy's bedtime stories; 7:50, dramatic review, Ailyn C. Sauer.

WMCA, New York, N. Y. (340.7), 4:45-4:55 p. m., beauty talk, Mme. Belle; 6:30-7:30, Aladdin dance orchestra; 8:15-8:20, health talk; 10-11, Chiropractic hour of music; 11-12, Ernie Golden and his Hotel McAlpin orchestra.

WNYC, New York, N. Y. (526), 6:50-7 p. m., market high spots; 7-7:25, song recital; 7:25-7:30, baseball results; 7:35-7:50, talk, Mayor John F. Hylan; 7:50-8, piano recital; 8-8:15, talk; 8:15-9:30, special concert feature; 10-10:30, Five Messner Brothers; 10:35-11, Five Messner Brothers.

WOO, Philadelphia, Pa. (508.2), 4:45 p. m., organ recital, Mary E. Vogt; 7:30, A. Candelori's concert orchestra.

WOR, Newark, N. J. (405.2), 3-3:10 p. m., talk on modern poets, Dr. Leon Mones; 6:15-6:30, Lorraine orchestra; 6:30-7, Man in Moon; 7-7:30, Lorraine orchestra.

Eastern Standard or Central Daylight Saving Time Stations

AT9, Fort Bragg, N. C. (435), 9 p. m., dance orchestra.

KDKA, Pittsburgh, Pa. (309.1), 2:30-7 p. m., baseball scores; 8:45, concert; 10:30, Grand theater.

KYW, Chicago, Ill. (535.4), 5:35-6 p. m., children's bedtime story; 6-6:30, dinner concert, Congress hotel; (Continued on page 11)



The six smiling boys in this picture compose Dixie's most popular jazz and dance orchestra, the Patio Royal dance orchestra of New Orleans which broadcasts from WSMB, every Monday from 8:30-10:30 p. m. Their particular brand of syncopation is well liked in the South. The Patio Royal dance orchestra is composed of Leslie C. George, director and banjoist; Clarence Erath, pianist; William Bruan, Jr., cornetist; Arthur Luquet, cornetist; Evans Zevely, saxophonist, and Louis Uhle, drummer.

MANGUSO FAMILY ENTERTAINS AT WGR

Tuesday, June 9

(Continued from page 10)

7-7:30, program, Chicago Musical college; 7:20-7:45, speeches, American Farm Bureau federation; 7:45-8:30, musical program; 9-10:30, evening at home, WBBM, Chicago, Ill. (226), 8-12 midnight, Sandy Keek, Scotch tenor; Harry Sosnik, pianist; Lester Kelsey;



Mary Ward (left) is one of the entertainers at WJJD, Mooseheart. She may be heard on the Palmer House program Monday. Mary (center) and Mike Manguso are part of the Manguso family which will put on a program Friday, June 12, at WGR, Buffalo. Mike is a saxophonist with Harold Gieser in the Vincent Lopez Hotel Statler dance orchestra. Little Mary will sing.

and his Rainbo Skylarks, Ned and Ches. Tommy Jancosek, harmonic soloist; Mack Sisters, Will Rositer, Nate Caldwell; 1-2, Ginger hour.
WRC, Washington, D. C. (468.5), 7 p. m., New Willard hotel orchestra; 8:30, "The Political Situation in Washington Tonight," Frederick William Wile; 9, "Over the Seven Seas"; 10, Le Paradis band; 11, Otto F. Beck, organist.
WREO, Lansing Mich. (285.5), 8:15-9:45 p. m., Reo broadcasting band; Willis trio; Alexander Gunn, pianist; Isador Geffen, cellist; Wilhelm Harmens, violinist; Reo male glee club; 10, baseball.
WSAI, Cincinnati, Ohio (326), 6:45 p. m., chimes; 7, Hotel Sinton instrumental trio; 8, Eveready hour of music; 9, WSAI studio; Lillian Dent, soprano; Mary Steele, contralto.
WTAM, Cleveland, Ohio (389.4), 6-7 p. m., Hotel Statler concert orchestra; Maurice Spitalny, director.
WTAS, Elgin, Ill. (302.8), 8-10:30 p. m., Joe Rudolph and the Boss's Own orchestra; Frank Morris, Polly Willis, Eddie and Fannie Cavanaugh, Coleman Goetz.
WTIC, Hartford, Conn. (348.6), 6:50 p. m., baseball score; 7, organ recital, Austin Organ company; 7:50, glee club, New Britain Normal school, Pauline Meyer, director; 8:10, "Citizens' Military Training Camps," Col. Emerson G. Taylor.
WVJ, Detroit, Mich. (352.7), 6 p. m., dinner concert; 7, concert from New York.

Central Standard Time Stations

CKY, Winnipeg, Can. (384.4), 8:30 p. m., French concert, Yvonne Thibault and party.
KFDM, Beaumont, Tex. (315.6), 7-7:30 p. m., children's program; 8-10:30, musicale.
KFMQ, Fayetteville, Ark. (299.8), 9 p. m., Fayetteville Community chorus, Prof. H. E. Shultz, director.
KFBU, Bristow, Okla. (394.5), 10:30-12 midnight entertainment.

6-6:30, Art Hickman's Biltmore hotel concert orchestra, Edward Fitzpatrick, director; 6:30-7:30, Little stories American history, Prof. Walter Sylvester Hertzog, weekly visit of Queen Titania and Sandman from Fairyland, Louis F. Klein, auto-harp and harmonica; Chas. Leslie Hill, readings; Floryane Thompson, soprano; 7:30-8, Piggly Wiggly girls' string trio; 8-10, program, Ferguson Travel Service; 10-11, Art Hickman's Biltmore hotel dance orchestra, Earl Burnett, leader.
KNX, Hollywood, Calif. (336.9), 5:30-6 p. m., Wuritzer pipe organ studio, Sid Ziff's sports talk; 6:15, travel talk, W. F. Alder; 6:30-7:30, program, Globe Ice Cream company; 7:30, style talk, Myer Siegel, Jr.; 7:45, health talk, Dr. Robt. T. Williams; 8-9, program, Elite Catering company; Elite concert trio; Louis Sullivan, contralto; 9-10, program, Independent Furniture Manufacturing company; 10-12, movie night, the Ambassador, Abe Lyman's Coconut Grove dance orchestra.
KPO, San Francisco, Calif. (428.3), 6:40-7 p. m., States Restaurant orchestra; 7-7:30, Rudy Seiger's Fairmont hotel orchestra; 8-9, Norwegian male chorus; 9-10, popular program; 10-11, Johnny Buick's Cabrians.

Wednesday, June 10

Wednesday, silent night for: AT9, CFAC, CFCA, CHIC, CHNC, CKAC, CKY, CNRT, KFDM, KFKX, KFMQ, KGO, KLDS, KOB, WBAV, WBBR, WGBL, WGED, WDWL, WEBJ, WEBW, WFAA, WFL, WGBS, WGY, WHAR, WHAZ, WIV, WMC, WOAW, WOI, WORD, WPG, WRBC, WRC, WREO, WTIC.

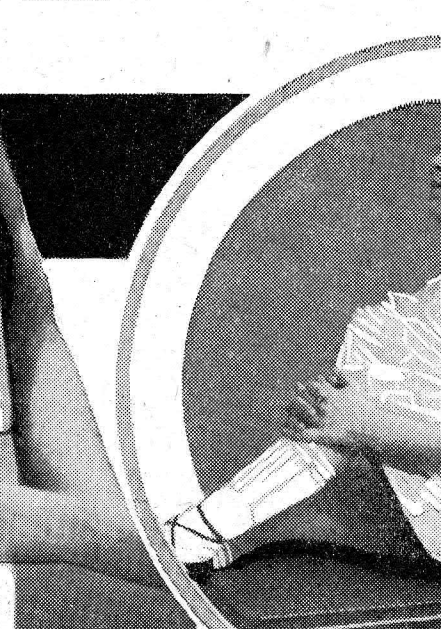

WMCA, New York, N. Y. (340.7), 3:45-9:55 p. m., talk, Alvin Silver company; 4-5, Original Indiana Five orchestra; 6:30-7:30, Ernie Golden and his Hotel McAlpin orchestra.
WNYC, New York, N. Y. (526), 6:50-7 p. m., market high spots; 7-7:25, song recital; 7:25-7:30, baseball results; 7:35-7:50, talk, Mayor John P. Hylan; 7:50-8, piano recital; 8-9, concert program; 9-9:15, "Timely Topics," F. P. Bent; 9:15-10:30, concert program.
WOO, Philadelphia, Pa. (508.2), 4:45 p. m., organ recital, Mary E. Vogt; 7:30, A. Candolor's concert orchestra; 8, concert from WPAE; 10:03, organ recital, Mary E. Vogt; 10:30, Vincent Rizzo's dance orchestra.
WOR, Newark, N. J. (405.2), 6:15-6:30 p. m., Tivoli orchestra; 7:30-8, Vincent Lopez' orchestra, U. S. School of Music; 8-8:10, topics of the day, Spencer Armstrong; 11-12, Cro's orchestra.

Eastern Standard or Central Daylight Saving Time Stations

KDKA, Pittsburgh, Pa. (309.1), 2:30-7 p. m., baseball; 8:45, Dry Siltz hour of music.
KYW, Chicago, Ill. (535.4), 6-6:30 p. m., dinner concert, Congress hotel; 7-8, Grace Hegseth, soprano; Robert Hene, baritone; Marguerite Jaimyfield, pianist; Joseph Kovacs, violinist; 9-11:30, evening at home.
PWX, Havana, Cuba (400), 8:30-11 p. m., band stand.
WBBM, Chicago, Ill. (226), 8-10 p. m., Tell Taylor, Ned Santry, Charlie Garland.
WCEE, Elgin, Ill. (275), 10:30-12, midnight, Joe Rudolph and the Boss's own orchestra; Frank Morris, Eddie and Fannie Cavanaugh, John Poat.
WCX, Detroit, Mich. (516.9), 4:15 p. m., musical program; 6, dinner concert, Book-Cadillac hotel; 7, musical program.
WEAO, Columbus, Ohio (293.9), 7:30 p. m., bedtime

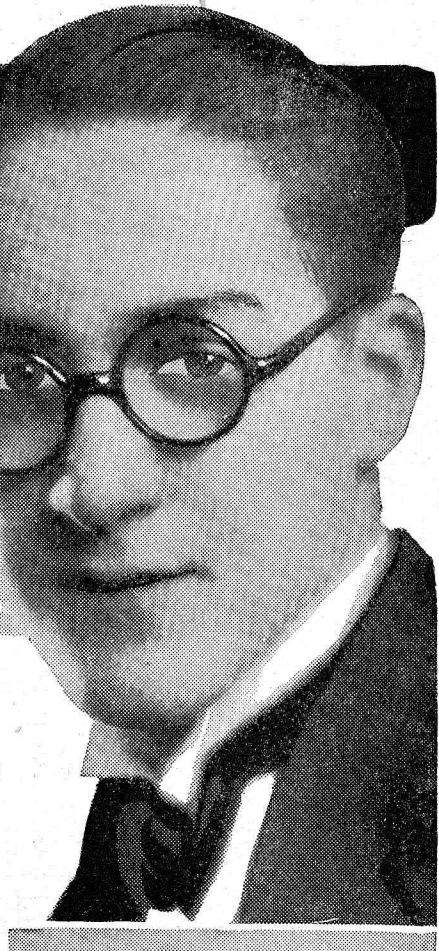

Ned Santry; Jerry Cromack; Sylvia Galnic, soprano; Tiny Dave Nudelmann, Chillon orchestra.
WCEE, Elgin, Ill. (275), 10:30-12 midnight, Joe Rudolph and the Boss's Own orchestra; John Poat, Polly Willis.
WCX, Detroit, Mich. (516.9), 4:15 p. m., musical program; 6, dinner concert, Book-Cadillac hotel; 10, The Red Apple club.
WEAR, Cleveland, O. (389.4), 7-10 p. m., WEAF program; 10-11, Metcalf Memorial organ recital, Vincent H. Percy.
WEBB, Chicago, Ill. (370.2), 7:30 p. m., Oriole concert orchestra; Lydia Lochner, contralto; 8:30, Frank Bordner, baritone; musical bits, Riviera theater; 9:30, Oriole dance orchestra; Dennis Sisters; Frank Magini, songs; 11:30-1, Oriole dance orchestra; Dennis Sisters; Frank Magini; Ted Fiorito, novelty pianist; Frank Bordner.
WGES, Oak Park, Ill. (250), 5:16:30 p. m., Katherine Forbes, soprano; Edgar Scott, tenor; Edna Wallace, soprano; McDebit Sisters; 6:30-7, bedtime stories, Cornelia Duncan; 10:30-1, A. Cavallo and his 11 master musicians; Sammy McTavish, comedian; Rudolph Hess, pianist; Sattelites orchestra; Coyne Electrical School serenaders.
WGN, Chicago, Ill. (370.2), 6:30-7:30 p. m., Drake concert ensemble, Blackstone string quintet; 8:30, studio program; 9, Radio interview with the weather man; 10:30-11:30, Drake Hotel Terrace Garden program.
WGY, Schenectady, N. Y. (379.5), 5:30 p. m., Hotel Van Curler orchestra; 6:35, "Police Courtesy," William H. Funston; 6:45, program, WGY Chamber Music ensemble; 7:10, program, Wanamaker auditorium; 8:10, WGY Chamber Music ensemble; 9, "Over the Seven Seas"; 10, Meyer Davis orchestra.
WHT, Deerfield, Ill. (399.8), 7-8:30 p. m., Dorothy Blum, soprano; Edward Kemp, tenor; Dorothy Wilkens, Thora Martens; Al Carney, organist; Agatha Karlen, reader; ballads, John Clark; 8:45-10:05, (238), Elmer Kaiser's Riverview Park Ballroom orchestra; 10:30-1, (399.8), Emil Rosseau, tenor; Ned Becker, gloom assassin; Eleanor Gilmour, soprano; Jane McConnell, contralto; Husk O'Hare's orchestra.
WJJD, Mooseheart, Ill. (302.8), 10:30 p. m., Rushmore ensemble, Geneva organ, Wanda Gail, Charley Straight's orchestra.
WKRC, Cincinnati, Ohio (422.3), 10 p. m., Cosmopolitan quintet; 11, Doc Howard's WKRC entertainers.
WLS, Chicago, Ill. (344.6), 6:30 p. m., Ralph Emerson, organist; 7:15, Cornhuskers; 7:45, lullaby time, Aunt Martha and Uncle George; 8, WLS theater, E. Warren K. Howe; classical program; 9, R. F. D. program; Jack Friedenberg, harmonic and banjo soloist; 10, WLS Harmony trio, Grace Wilson, contralto; 10:20, Williamson Brothers and Phil; 10:40, Nubs Allan, contralto; 10:50, Col. George Valodsky, Russian pianist; 11:10, Cornhuskers' orchestra; 11:20, Solemn Old Judge's program, minstrel show; 12:1, a p. m., revue.
WLW, Cincinnati, O. (422.3), 4 p. m., recital, pupils of Stuffregen studios; 7, dinner hour concert; 8, special program, talent from College Hill; 9, concert program, Formica concert orchestra.
WMAQ, Chicago, Ill. (447.5), 6 p. m., Chicago theater organ; 6:30, Hotel LaSalle orchestra; 8, Harry Hansen; 8:20, talk on city's water supply, Col. A. Sprague; 8:40, weekly talk, Association of Commerce; 8:50, lecture, University of Chicago; 9:15, Stevens Ladies' chorus.
WMBB, Chicago, Ill. (250), 7-8:30 p. m., semi-classical program, J. Bodewalt Lampe, director; Beatrice Teller and Trianon ensemble; Ambrose Wyrick, Rita McFawn; Hazel O'Neil; Armin F. Hand and the Woodlawn theater orchestra; 8:30-10:30, Dell Lampe and Trianon orchestra; Johnnie Keane, Bron Duffy, Geraldine Doyle, Charles Agne and Trianon syncopators, Fisher and Smith.
WQJ, Chicago, Ill. (447.5), 7-8 p. m., Rainbo Garden orchestra, Mrs. Adelaide Steeg, contralto; Leon Byram Reed, violinist; Mrs. A. Scott Armstrong, accompanist; Mildred Perlin, reader; 10-1, Ralph Williams

KFVE, University City, Mo. (240), 6 p. m., Radiocast review, Romaine Fielding; song recital, Joan Arliss; orchestra; dance numbers; Romaine Fielding, reader.
KLDS, Independence, Mo. (268), 8 p. m., program, Amy Winning, director.
KSD, St. Louis, Mo. (545.1), 6:30 p. m., Abergh's concert ensemble; Arne Arnesen, violinist.
KTHS, Hot Springs National Park, Ark. (374.8), 8:30-8:40 p. m., baseball; 8:40-9:15, classical and ballad recital, New Arlington hotel orchestra; 9:15-10, Ray Mullin's Whittington Park orchestra.
WBAP, Ft. Worth, Tex. (475.9), 7:30-8:30 p. m., classical program, Helen Brandies; 9:30-10:45, Sweetwater violin choir.
WCCO, Minneapolis-St. Paul, Minn. (416.4), 6 p. m., baseball; 6:05, Biley's St. Paul hotel orchestra; 7, national program from WEAF; 8, musicale; 9, baseball.
WDAF, Kansas City, Mo. (365.6), 6-7 p. m., piano tuning-in number on the Duo-Art; Tell-Me-a-Story Lady; Radio piano lessons, Maudellen Littlefield; Plantation players; 11:45-1, Newman nighthawk night.
WEBW, Beloit, Wis. (268), 8:30-9:45 p. m., band concert, quartet, Fairbanks, Morse company.
WFAA, Dallas, Texas (475.9), 6:30-7:30 p. m., Haualea School of Hawaiian music; 8:30-9:30, Mrs. Albert E. Smith, soprano; 11-12, Dwight Brown, organist.
WHAS, Louisville, Ky. (399.8), 9:15 p. m., baseball; 7:30-9, concert, Louisville Provision company.
WHO, Des Moines, Ia. (526), 7:30-9 p. m., Indian program.
WMC, Memphis, Tenn. (499.7), 8:30 p. m., program, O. H. Muehler; 11, Harry Nichols, organist.
WOAN, Lawrenceburg, Tenn. (282.8), 12:15-12:45 p. m., Vaughan Radio orchestra; 9-10, Vaughan Radio orchestra; male quartet; Vaughan Recording male quartet.
WOAW, Omaha, Neb. (526), 6 p. m., "Advice to the Lovelorn," Cynthia Grey; 6:20, baseball; 6:25, May Seed & Nursery company; 9, Fontenelle celebration association; 12, Riello midnight frolic.
WOC, Davenport, Ia. (465.6), 8-8:30, "Some Interesting Facts about Radio," Telegraph, H. B. Peaham.
WSB, Atlanta, Ga. (428.3), 5-6 p. m., Bonnie Barnhardt's bedtime story; music; 8-9, Vick Myers Melody artists, Dixie Sunbeams; 10:45, entertainment.
WSMB, New Orleans, La. (319), 6:30-7:30 p. m., dinner music, baseball.

Mountain Standard Time Stations

CNRR, Regina, Canada (356), 8-10 p. m., bedtime travel tale; H. J. Record concert orchestra.

Pacific Standard Time Stations

KFI, Los Angeles, Calif. (467), 5:30-6 p. m., Examiner's matinee program; 6-6:15, McDaniels' nightly doings; 6:45-7, radiotelegraph talk; 7-8, program, Hills Brothers; Carey male quartet; the blue streak of Radio; Way Watts and his ukulele; Hills Brothers dinner-dance orchestra; 8-9, Examiner's program, Monrovia, California community orchestra; 9-10, Willshire string trio, Agnes Kraemer, dramatic soprano; 10-11, Packard ballad hour, Billy and Polly Hall, Ashley Sisters, Ray Wood, Way Watts and others.
KFWB, Hollywood, Calif. (522), 7:45-9 p. m., program, Western Super-service garage, Marguerite Anderson, concert pianist, Great Western male quartet, Erickson sisters; 9-10, feature program, Union Oil company of California; 10-11, Warner Brothers frolic, direction Charlie Wellman.
KGO, Oakland, Calif. (361.2), 8 p. m., Kohler & Chase; Lina Torano, accordionist; Elsa Behlow Trautner, soprano; Carey male quartet; Marino Ladres' orchestra; Ray Nealson, tenor; Nona A. Campbell, soprano; 10-1, Henry Halstead's orchestra.
KGW, Portland, Ore. (491.5), 7:30-8 p. m., baseball; 9-10, concert, Woolach and Powell company; 10-12, Herman Kenin's Multnomah hotel dance orchestra.
KHJ, Los Angeles, Calif. (405.2), 5:30-6 p. m., Leighton's Arcade cafeteria orchestra, Jack Cronshaw, leader;

Atlantic or Eastern Daylight Saving Time Stations

CNRO, Ottawa, Can. (435), 8 p. m., Chateau Laurier concert orchestra; 9, Books for Children, Lawrence Burpee; Fourth Avenue Baptist choir program; Chateau Laurier dance orchestra.
WAHG, Richmond, Hill, N. Y. (315.6), 7:30-7:45 p. m., sport talk, Thornton Fisher; 7:45-8, musical glasses, A. W. Bennett; 8-8:15, James M. Savell, baritone; 8:15-8:30, Queenie M. Goldman pianist; 8:30-8:45, Arnold T. Koch, cellist; 8:45-9, Frank Ochs, tenor; 9-9:15, A. W. Bennett; 9:15-9:30, James M. Savell; 9:30-9:45, Queenie M. Goldman; 9:45-10, Frank Ochs; 10-10:55, Glen C. Smith's Paramount orchestra; 11:05-11:30, Glen C. Smith's orchestra.
WBZ, Springfield, Mass. (335.3), 6 p. m., Hotel Kimball trio; 6:30, Radio nature story, Thornton W. Burgess; 8, Marie Dutton, comedienne, Edson Ferrell, accompanist; 8:15, Edward J. McLaugh, baritone; 8:30, Mrs. P. J. Donovan, soprano; 8:45, American Legion Fire and Drum corps; 9:15, to be announced; 9:40, "Recreational Attractions of New England," Denny B. Goode; 9:50, baseball.
WCAE, Pittsburgh, Pa. (461.3), 6:30 p. m., dinner concert, William Penn hotel; 8:30, Mario; 9, concert; 10, concert.
WCAU, Philadelphia, Pa. (245), 6 p. m., Hotel Pennsylvania Inter-fraternity orchestra; 8, recital; 8:45, N. B. T. Boys' concert; 9:20 talk; 10:10, Radio talk; 10:30, Jack Myers' Musical Architects' dance orchestra.
WEAF, New York, N. Y. (491.5), 6-7 p. m., dinner music, Waldorf-Astoria; 7-7:30, services United Synagogue of America; 7:30-7:45, Max Olanoff, violinist; 7:45-8, Mabel Bowland, impersonator; 8-9, U. S. Navy Band, direction Lieutenant Charles Benter; 9-10, Ipana Troubadours; 10-11, Royal Little Symphony 11-12, Ben Bernie's Hotel Roosevelt orchestra.
WEI, Boston, Mass. (476), 6:30 p. m., Big Brother club; 7:15, talk; 8, Traveler Shoe concert; 8:30, M. B. Cohen's half hour musical; 9, musical; 10, De Lancy Cleveland and assisting artists; 10:30, Joe Beal and entertainers.
WFI, Philadelphia, Pa. (394.5), 3 p. m., Loretta Kerk, pianist; 6:30, Bellevue Stratford concert orchestra; 7 bedtime stories.
WGBS, New York, N. Y. (315.6), 6-6:30 p. m., Uncle Geesbe; 6:30-7:30, Elite orchestra.
WGR, Buffalo, N. Y. (319), 2:30-4:30 p. m., WGR's afternoon program, A. J. Erisman, director; 9-10, musical program, Mr. and Mrs. Vernon Curtis; 10-11:30, Hawaiian guitar duo; 10:15-10:30, George Phelps, popular soloist; 10:30-10:45, Rev. Samuel Arluck, tenor soloist; 11-11 a. m., supper dance music; Vincent Lopez Hotel Statler dance orchestra, Harold Gieser, director.
WHN, New York, N. Y. (360), 7:30-7:35 p. m., health talk, Dr. Landis; 8:15-8:30, Rubey Cowan, tenor; 9-10, Consolidated Dairy orchestra; 10-10:30, Roseland dance orchestra; 10:30-11, Palisades Amusement Park orchestra; 11:30-12, Silver Slipper revue and orchestra; 12-12:30, m. Strand Roof orchestra.
WIP, Philadelphia, Pa. (508.2), 3 p. m., recital, students of Kurtz Vocal studios; 6:05, Benjamin Franklin concert orchestra; 7, Uncle Wip's bedtime stories; St. Elizabeth's Parochial school band.
WIAR, Providence, R. I. (305.9), 7:30 p. m., New York
WJZ, New York, N. Y. (454.3), 7-8 p. m., Cafe Boulevard orchestra; 8-8:10, Wall Street Journal review; 8:10-8:30, NYU Air College; 9:15-10:30, U. S. army program; 10:30-11:30, Monte Carlo Virginians.
WKAQ, San Juan, P. R. (340.7), 8-10 p. m., municipal band.
WLI, Philadelphia, Pa. (394.5), 4:30 p. m., Magazine Corner, Mrs. F. Maschal; Marcelle North, pianist; 7:30, Dream Daddy's bedtime stories; 8, concert, Brooklyn Square Glee club; 9, automobile talk; spelling bee for bank championship of Philadelphia; 10, Arcadia cafe dance orchestra.

stories, Justice Carter; 8, Roberts string quartet; Zella Roberts, harpist; Mae Skinner, violinist; Ann Charles, violinist; Ethel Harris, cellist.
WEAR, Cleveland, Ohio (389.4), 7-8 p. m., concert, Hotel Cleveland orchestra; Ivan Francis, conductor.
WEBB, Chicago, Ill. (370.2), 7:30 p. m., Oriole concert orchestra; Cyril Allen, cellist; Louis Bartlett, pianist; "Books of the Day," Lewellyn Jones; 9:30, Oriole dance orchestra; Robert York, tenor; 10:30, brass quartet, Kay Ronayne, songster; 11:30-1, songs, Comman Brothers; Robert York, Kay Ronayne.
WGES, Oak Park, Ill. (250), 5-6:30 p. m., Margaret Hayes, soprano; Bryce Talbot, baritone; Frank Grief, tenor; Howard Newmiller, pianist; 6:30-7, bedtime stories; 10:30-1, A. Cavallo and his 11 master musicians; Ralph Olson, pianist; Andrea Scarlatti, tenor; Coyne Electrical School serenaders.
WGN, Chicago, Ill. (370.2), 6:30-7:30 p. m., Drake concert ensemble, Blackstone string quintet; 8:30-9:30, studio program; 10:30-11:30, Drake Hotel Terrace Garden program.
WGY, Schenectady, N. Y. (379.5), 5:45 p. m., Albany Strand theater symphony orchestra; Julius Boxhorn, conductor; Floyd H. Walter, organist; 6:30, feature, Child's Book of Knowledge.
WHT, Deerfield, Ill. (399.8), 7-8:30 p. m., Madame Emmy Ohl, soprano; Herman Bing, baritone; Oscar Heather tenor; Al Carney organist; ballads, John Clark; 8:45-10:05, (238), Elmer Kaiser's Riverview Park orchestra; 10:30-1, (399.8), Lydia Lockner, contralto; Brock Sisters; Al Carney; Husk O'Hare's orchestra.
WJJD, Mooseheart, Ill. (302.8), 10:30 p. m., Emily Schneider, Clarence Harper, Rudy Patek, Geneva organ, Charley Straight's orchestra.
WKRC, Cincinnati, Ohio (422.3), 8 p. m., weekly book review, reading course, Alice B. Coy; 8:15, Lelia LeMarr, pianist; 8:45, special features; 9:15, Bob Croenke, Jim Mischler.
WLS, Chicago, Ill. (344.6), 6:30 p. m., Ralph Emerson, organist, Martha Meier, contralto; 7:15, Cornhuskers; 7:45, lullaby time, Aunt Martha and Uncle George; 8, Blanch Belka, mezzo-soprano; Roy Coleman, tenor; 8:15, Lone Scouts; 8:45, WLS theater; 9, R. F. D. program; 10, Nubs Allen, contralto; 10:10, Czechoslovakian choral society, classical and national songs; 11, Cornhuskers' orchestra.
WLW, Cincinnati, Ohio (422.3), 4 p. m., Shut-in program; 7, dinner hour concert, Hotel Gibson orchestra, Robert Visconti, director; 10, piano recital, "Scenes from Many Lands; 11, Organ concert, Johanna Grosse.
WMAQ, Chicago, Ill. (447.5), 2:45 p. m., Cubs-New York baseball; 6, Chicago theater organ; 6:30, stories for children, Georgene Parkner; 8, lecture, Northwestern university; 8:25, piano concerto, Carol Hurlbut, Kathleen McKittrick; 8:45, WMAQ players.
WMBB, Chicago, Ill. (250), 7-8:30 p. m., operatic program, J. Bodewalt Lampe, director; Beatrice Teller and Trianon ensemble, Ambrose Wyrick, Rita McFawn, Hazel O'Neil, Armin F. Hand and the Woodlawn theater orchestra; 8:30-10:30, Dell Lampe and Trianon orchestra, Cecil Ward, George Foraythe.

(Continued on page 12)

COOLIDGE'S TALK AT NORSE-AMERICA

Index to Popular Concerts

TABULATED below is a time table of the stations giving popular concerts this week. Stations are divided into the four different standard times in use. The hours are given in the kind of time in use at each listed station. By using this table as an index and referring to the complete programs below, full information will be obtained.

Popular

Atlantic or Eastern Daylight Saving Time Stations

Saturday, June 6: 6:05, WIP; 7: WNYC; 7:15, WEAF; 7:30, WHAR; 8:15, WEAF; 8:55, WEAF; 9:30, WFI; 9:45, WNYC; 10:15, WEAF; 10:30, WEAF.

Sunday, June 7: 7:20, WCAE, WEAF, WEEL, WJAR; 9, WNYC; 10, WHN.

Monday, June 8: 7, WNYC; 7:30, WHAR; 7:45, WAHG; 8:30, WOO, WOR; 8:45, WAHG; 9, WEAF, WEEL, WJAR; 9:15, WAHG; 9:30, WHN; 10, WMCA; 10:45, WOR.

Tuesday, June 9: 7:30, WEAF, WHAR; 8:30, CKAC, WCAE, WDFW, WEAF, WFL, WEEL, WJAR; 9, WIP; 10, WGBS, WNYC; 10:35, WNYC; 11, WGBS; 12, WHN.

Wednesday, June 10: 8:15, WAHG, WHN; 10, WGR; 10:15, WGR; 10:30, WEEL.

Thursday, June 11: 7:30, WEAF, WGBS; 8, WGR, WHN; 8:30, CKAC; 9, CHNC, WEAF, WGBS; 9:30, WGBS; 10, WHN; 12, WHN.

Friday, June 12: 6:30, WGBS; 7, WGR; 7:30, WHAR; 7:45, WAHG; 8, WAHG, WEAF; 8:15, WEBJ; 8:30, WAHG, WEAF; 9:30, WAHG, WEEL, WHN; 10, WGR, WLIT; 10:30, WLIT; 11:30, WHN; 12, WHN.

Eastern Standard or Central Daylight Saving Time Stations

Saturday, June 6: 6, WIBO; 8, WBBM, WIBO, WLS, WHAQ; 8:30, WMBB; 9, WBBM, WLS, WTAM; 9:30, WEBB, WMBB; 10, WBBM, WKRC, WLS, WQJ, WRC, WTAM; 10:30, WEBB, WGES, WJJD; 10:40, WSAI; 11, WBBM, WKRC, WLS, WQJ, WTAM; 11:30, WEBB, WGES; 12:35, WSAI; 1, WQJ; 1:20, WSAI; 2, WQJ; 2:40, WSAI.

Sunday, June 7: 6:20, WWJ; 8, WBBM, WTAS; 8:30, WTAS; 9, WBBM; 9:30, WTAS; 10, WIBO; 10:30, WJJD, WTAS; 11, WIBO; 11:30, WTAS; 12, WBBM.

Monday, June 8: 6:35, WGY; 8, WTAS; 9, WTAS; 10, WKRC, WSAI, WTAS; 10:30, WJJD; 11, WKRC; 12, WKRC.

Tuesday, June 9: 7, WSAI; 8, WBBM, WTAS; 8:15, WREO; 9, WBBM, WEAR, WTAS; 9:30, WEBB; 10, WBBM, WKRC, WQJ, TWAS; 10:30, WEBB, WJJD; 11, WBBM, WKRC, WQJ; 11:30, WEBB; 12, WQJ; 12:30, WEBB; 1, WQJ.

Wednesday, June 10: 8, WBBM, WTAS, WWJ; 8:15, WKRC; 8:30, WEBB; 8:45, WKRC; 9, WBBM, WTAS; 9:15, WKRC; 9:30, WEBB; 10, WTAS; 10:10, WSAI, WQJ; 10:30, WEBB, WJJD; 11, WQJ; 11:30,

WEBB; 12, WQJ; 12:30, WEBB; 1, WQJ.

Thursday, June 11: 6:30, WSAI; 7:30, WSAI; 8, WBBM, WTAS; 8:15, WREO; 8:30, WEBB; 10, WBBM, WTAS, WQJ; 10:30, WEBB; 11, WBBM; 11:15, WLW, WQJ; 12, WEBB, WQJ; 1, WQJ.

Friday, June 12: 8, WBBM, WTAS; 8:30, WEBB; 9, WBBM, WTAS; 10, WEBB, WTAS, WQJ; 10:30, WJJD; 11, WEBB, WQJ; 12, WEBB, WQJ; 1, WQJ.

Central Standard Time Stations

Saturday, June 6: 6:30, WFAA; 8, WSB; 8:30, WSMB; 9, KFRU, WAMD; 9:30, WSMB; 10, KFRU, KFVE, WAMD; 10:45, WSB; 11, KFAB; 11:45, WDAF.

Sunday, June 7: 9:30, WFAA; 10:30, WFAA; 11, WBAP.

Monday, June 8: 6:30, WOAW; 6:45, WCCO; 7:30, KFAB, WBAP, WHO; 8, WCCO; 8:30, KFAB, KFRU, WSMB; 9, KSD; 9:30, KFRU, WBAP; 10, WOI; 10:45, WSB; 11:45, WDAF.

Tuesday, June 9: 8, WSB; 9, WOAW; 10:30, KFRU; 10:45, WSB; 11, KFAB; 11:30, KFRU; 11:45, WDAF; 12, WOAW.

Wednesday, June 10: 7:30, KFAB, WHO; 8, KFRU; 8:30, KFAB, WSMB; 9:30, KFRU; 11:45, WDAF.

Thursday, June 11: 7, WOAW; 8, WSB; 9, WOAW; 11, WFAA; 11:45, WDAF.

Friday, June 12: 7:30, KFAB, WHO; 8, WDAF, WSB; 8:30, KFAB, WFAA, WHO; 9, WCCO; 11, KFRU; 11:45, WDAF; 12, KFRU.

Mountain Standard Time Stations

Monday, June 8: 8, KOA.

Wednesday, June 10: 8, KOA.

Friday, June 12: 8, KOA.

Pacific Standard Time Stations

Saturday, June 6: 8, KFVB, KNX; 9, KFVB, KNX; 10, KFI, KFVB; 11, KFI, KNX; 11:30, KHJ; 12, KFI, KNX; 12:30, KHJ; 1, KFI, KNX; 2, KFI.

Sunday, June 7: 8, KHJ; 9, KFVB; 10, KFVB.

Monday, June 8: 8, KFVB, KNX; 9, KNX; 10, KFI, KFVB, KNX.

Tuesday, June 9: 8, KFI, KHJ, KNX; 9, KFI, KFVB, KHJ, KNX, KPO; 10, KFVB, KNX; 11, KGW, KNX.

Wednesday, June 10: 7:30, KFI; 8, KFVB, KGW; 9, KFI, KFVB; 10, KFVB, KGW, KNX; 11, KNX.

Thursday, June 11: 8, KHJ, KNX; 9, KFVB, KHJ; 10, KFI, KFVB, KHJ; 11, KNX.

Friday, June 12: 8, KFVB; 9, KFI, KFVB, KHJ; 10, KFVB, KNX; 10:30, KGW; 11:30, KGW.



Viola Scherer, soprano, is a favorite with the fans of WAHG. She will sing June 15. Singin' Joe Easton is WOAW's baritone and may be heard any week at this station. He is seen here with Lester Palmer, pianist-composer.

zoo, orphan kiddies of Los Angeles with Harry James (Cousin Jim); Dick Winslow, juvenile reporter; Baby Muriel MacCormac and Mickey McBan, screen starlets; 8, Dr. Mars Bumgardt, scientific lecturer; 8:30-10:30, program, Broadway Department store; 10:30-11:30, Art Hickman's Biltmore hotel dance orchestra, Earl Burnett, leader.

Thursday, June 11

Thursday, silent night for: CHIC, CHNC, CHYC, CNRT, KFAB, KFAE, KFDM, KFMX, KFOA, KOA, KOB, KSD, PWX, WAHG, WBAV, WCEE, WEBB, WEBJ, WEBW, WHA, WHAD, WHAZ, WJJD, WKRC, WRBC, WSAI, WTAM.

Atlantic or Eastern Daylight Saving Time Stations

CKAC, Montreal, Can. (410), 4:45 p. m., cabaret, Wind-sor hotel; 8:30, C. N. R. entertainers.

CNRM, Montreal, Can. (411), 9 p. m., orchestra, White Star-Dominion line; Bessie Anderson, soprano; P. B. Collier, tenor.

WAHG Richmond Hill, N. Y. (315.6), 12:30-1:05 p. m., Banjo Eddie.

WBBR, New York, N. Y. (272.6), 8 p. m., Watchtower instrumental trio; George Twarosch, Carl Park, Malcolm Carment; 8:10, Carl Park, violinist; 8:20, Sunday school lesson, S. M. Van Sinder; 8:40, Malcolm Carment, clarinetist; 8:50, Instrumental trio.

WBZ Springfield, Mass. (333.3), 6 p. m., Leo Reisman Hotel Lenox ensemble; 7:30, U. S. Marine band; 9:40, "Bringing the World to America," Our World; 9:50, baseball.

WCAE, Pittsburgh, Pa. (461.3), 6:30 p. m., dinner concert, William Penn hotel; 7:30, Uncle Kaybee; 8, Silvertown Cord orchestra.

WCAU, Philadelphia, Pa. (245), 6 p. m., Hotel Pennsylvania Inter-fraternity dance orchestra; 7:30, N. Snellenburg and Co. symphony orchestra; 8, talk, Clara Zillessen; 9, recital; 10:45, Jack Myers' Musical Architects dance orchestra.

WDFW, Providence, R. I. (440.9), 6:30-8 p. m., Narragansett hotel orchestra.

WEAF, New York, N. Y. (491.5), 6-7 p. m., dinner music, Waldorf-Astoria; 7-7:30, services, Greater New York Federation of Churches; 7:30-8, Cushman Serenaders; 8-8:30, special entertainment, Annual Dinner of Alumni association of Massachusetts Institute of Technology; 8:30-9, "The Packard Eight," George Elliott Cooley; 9-10, Atwater-Kent Radio Artists; 10-11, Silvertown Cord orchestra; 11-12, Vincent Lopez' Hotel Pennsylvania orchestra.

WEEI, Boston, Mass. (476), 6:30 p. m., Big Brother club; 7:15, musicale; 8, New York; 9, Atwater-Kent orchestra; 10, Goodrich Silvertown Cord orchestra.

WFI, Philadelphia, Pa. (394.5), 3 p. m., Housewives' Radio exchange and garden talk, Mabel Swint Ewer; 6:30, Bellevue Stratford concert orchestra; 7, bedtime stories; 8, concert from WEAF; 9, Atwater-Kent Radio artists; 10, Silvertown Cord orchestra.

WGBS, New York, N. Y. (315.6), 5-4 p. m., Jewish program, director of Foreign Language Information Service; 6-6:30, Uncle George; 6:30-7, Pearl House orchestra; 7:20-7:30, George Dale, tenor; 7:30-8:30, California Ramblers; 9:30-8:40, closing of play contest, Oliver Saylor; 9-9:30, Solomon Pinsler, pianist; 9:30-10:30, Piccadilly theater program.

WGR, Buffalo, N. Y. (319), 2:30-4:30 p. m., WGR's afternoon program, A. J. Erisman, director; 6:30-7:30, piano recital; 8-11, joint management information meeting, including annual dinner, Alumni association of the Massachusetts Institute of Technology with WEAF's Hall, Boston; the Tolleson trio; Atwater-Kent program, Goodrich Silvertown Cord orchestra.

WHAR, Atlantic City, N. J. (275), 7:30 p. m., Seaside hotel trio; 8, concert; 9, Shelburne hotel concert orchestra.

WHN, New York, N. Y. (360), 7-7:30 p. m., Silver Service; 7:30-7:35, health talk, Dr. Landis; 8-8:30, Will Oakland's Chateau Shanley; 9:30-10, Palladium Amusement Park orchestra; 10-10:30, Loew's vaudeville headliners; 12-12:30 a. m., Parody club revue and orchestra.

WIP, Philadelphia, Pa. (508.2), 6:05 p. m., Benjamin Franklin concert orchestra; 7, Uncle Wip's bedtime

stories; 8, Junior orchestra, West Philadelphia High School for Boys; 9, Lehigh Valley Railroad glee club; 11, Howard Lanin's dance orchestra.

WJAR, Providence, R. I. (305.9), 8 p. m., program from New York; 9, Victor presentation; 10, Goodrich Silvertown Cord orchestra.

WJY, New York, N. Y. (405.2), 8:15-8:25 p. m., talk, Field and Stream magazine; 10:30-11:30, Billy Wynne's Greenwich Village Inn orchestra.

WJZ, New York, N. Y. (454.3), 7-8 p. m., Bernhard Levitov's Hotel Commodore orchestra; 8-8:10, Wall Street Journal review; 8:10-8:30, NYU Air college; 8:30-10, U. S. Marine band; 10-10:30, staff recital, Keith McLeod, pianist; Godfrey Ludlow, violinist; Milton J. Cross, tenor.

WKAQ, San Juan, P. R. (340.7), 8:30-10 p. m., musical concert, La Cafetera.

WLIT, Philadelphia, Pa. (394.5), 4:30 p. m., garden talk; 7:30, Dream Daddy's bedtime stories.

WMCA, New York, N. Y. (340.7), 11-12 p. m., Ernie Golden and his Hotel McAlpin orchestra.

WNYC, New York, N. Y. (526), 6:50-7 p. m., market high spots; 7-7:25, song recital; 7:25-7:30, baseball results; 7:35-8, talk, Mayor John F. Hyland; 8-9, dance program, Harnett Donaldson and his orchestra; 9-10:30, concert program.

WOR, Newark, N. J. (405.2), 6:15-7:30 p. m., Tom Cooper's orchestra.

Eastern Standard or Central Daylight Saving Time Stations

AT9, Fort Bragg, N. C. (435), 9 p. m., dance orchestra.

KDKA, Pittsburgh, Pa. (309.1), 2:30-7 p. m., scores; 8, program, National Stockman and Farmer study; 8:45, Teaberry time; 9:55, baseball; 10:30, concert, Pittsburgh Post studio.

KYW, Chicago, Ill. (535.4), 6-6:30 p. m., dinner concert, Congress hotel; 6:35-6:55, speeches, American Farm Bureau federation; 7-7:30, "Twenty Minutes of Good Reading," Rev. C. J. Perrin; 7:30-8:15, Adelaide Timereck, contralto; Jack Walker, tenor; Katherine Johnson, soprano; Kathryn Bassi, harpist; 8:20, "Why Is Corned Beef?" John C. Cutting; 9-9:30, evening at home.

WBBM, Chicago, Ill. (226), 8-12 midnight, Maurice Streman, tenor; Sylvia Galnic, soprano; Tiny Dave Nudelman, George Givot, Crillon orchestra.

WGX, Detroit, Mich. (516.9), 4:15 p. m., musical program; 6, dinner concert, Book-Cadillac hotel; 7, musical program.

WEAR, Cleveland, Ohio (389.4), 7-9 p. m., WEAF program; 9-10, Metcalf Memorial organ recital, Vincent H. Percy; 10-11, musical program.

WEBB, Chicago, Ill. (370.2), 7:30 p. m., Oriole concert orchestra; Edwin Kemp, tenor; 8:30, musical bits, Riviera theater; 9:30, Oriole dance orchestra; Belle Forbes Cutter, soprano; Beulah Lodon, violinist; LeRoy North, pianist; 11:30-1 Oriole dance orchestra; songs Paul Small; songs, Wayne Myers; Belle Forbes Cutter, soprano; Edwin Kemp.

WGES, Oak Park, Ill. (250), 5-6:30 p. m., Edgar Scott, tenor; Katherine Forbes, soprano; Edwin Kemp, tenor; 6:30-7, bedtime story; 10:30-1, A. Cavallo and his 11 master musicians; Emily Lide, comedienne; Louis Butler, tenor; Edwin Barge, pianist; Coyne Electrical School serenaders; Coyne Electrical School orchestra.

WGN, Chicago, Ill. (370.2), 6:30-7:30 p. m., Drake concert ensemble, Blackstone string quintet; 8:30-9:30, studio program; 10:30-11:30, Drake Hotel Terrace Garden program.

WGY, Schenectady, N. Y. (379.5), 5:30 p. m., program, Hotel Ten Eyck orchestra; 6:35, "Artificial Silk," A. Stanley Talbott; 6:45, Troy Salvation Army band; W. J. Stredler, bandmaster; 8, Marine band program; 10:30, organ recital, Stephen Boiscclair.

WHT, Deerfield, Ill. (399.8), 7-8:30 p. m., Marilla Galsworthy, soprano; Tony Corcoran, baritone; Margaret Garrity, pianist; Dorothy Wilkens, Thora Martens; Al Carney, organist; 8:45-10:05, (238), Elmer Kaiser's Riverview Park Ballroom orchestra; 10:30-1, (399.8), Sandy Meek, tenor; Ned Becker, gloom assassin;

DANCE

(Central T)

Saturday, Jun
Kgw, Wpg; 8:
8:30, Ksd, We
Wgbs; 9, Kfw
Wor, Wpg, W
Wtas; 9:30, K
Wre; 10, KF
Kpo, Wahg, W
Kfoa, Webh, W
Kfab, Wamd, W
Wreo; 11:45, V
Kgo, Kgw, Kn
Kfoa; 12:50, K
Khj; 2:30, Khj.

Monday, Jun
Whit, Wnye, W
8:15, Wahg; 8:
8:30, Wmca,
Wmb; 8:45, K
Kfi, Wtas; 9:
Wjld, Wmca, V
Wgr, Wtas; 10:
Wcee; 11, Kfw
Wdaf; 12, Kfi, 2
Kpo; 1, Knx.

Tuesday, Jun
Wtas; 8:30, Ch
Webb, Wwip; 8:
Weaf, Wmca, W
9:05, Wahg; 9:
9:30, Wbap, W
Whn; 10, Wg
Wcee, Webh, V
Kfab, Wbap;
Wdaf; 12, Kf
Knx, Kpo, Wc
Kfoa.

Wednesday,
S, Whn, Whi
Wnj; 8:30, We
Whn, Wjz;
Kfwb, Weaf, V
Wtas; 9:05, W
Wbap, Wgn, V
Who; 10, Wg
10:30, Wceo,
Webh, Who, Wj
Wtas; 11, Kf
Kpo; 11:45, V
Kfi, Kpo, Wg
Khj.

Thursday, Jun
Weaf, Weel, W
Wjar, Wsal, W
Webh, Wjy, Wf
Wtas; 9, Kf
Wjz, Wmca, V
9:30, Kfxx, W
Wsmb, Wtas; 9:
Kfwb, Whn; 10:
Webh, Wtas;
Woc; 11:45, V
Kfi, Kgo, K
Kpo, Wqj.

Friday, June
Wear, Whi, W
8:30, Wahg, W
Whn, Woc; 9:
Wex, Weaf, W
Wjz, Wtas; 9:
9:15, Kths; 9:
Cnrz, Wgn,
Wceo, Wgr, Wj
Webh, Wjld, V
Who; 11:45, V
Khj; 12:05, K

Wednesday, June 10

(Continued from page 11)

Morey Alswang, Gillis & Owen, Anna Fleming Kenney, Lindsey McPhail, Clyde Hager.

WQJ, Chicago, Ill. (447.5), 7-8 p. m., Rainbo Garden orchestra; Jean Ballard, contralto; Gertrude Wolf Quentlin, soprano; Fayette Miller, baritone; 10-1, Rainbo Skyarks; Betty Davis, Grown of the Air; Melodians, Fred A. Jacobsen, Ziegler Sisters, Hickey and Johnson, Brundage and Kraemer; 1-2, Ginger hour.

WRC, Washington, D. C. (468.5), 5-6:30 p. m., U. S. Marine band.

WREO, Lansing, Mich. (285.3), 10 p. m., baseball.

WSAI, Cincinnati, Ohio (326.7), 7 p. m., Freda Sanker's Bandool orchestra; 10, art talk; 10:10, Congress playing card string quartet; Chester Miller, baritone; 11, Helene Kessing, soprano.

WTAM, Cleveland, Ohio (389.4), 6-7 p. m., Phil Spitalny's dance orchestra; 8-10, Hruby conservatory faculty and students' program; 10-11, Hollenden hour, Carl Rupp and his Hotel Hollenden entertainers; 11-12, Budell Beach orchestra.

WTAS, Elgin, Ill. (302.8), 8-10:30 p. m., Villa Olivia Radio concert; Frank Morris, Polly Willis, Eddie and Fannie Cavanaugh.

WTIC, Hartford, Conn. (348.6), 6:50 p. m., baseball scores.

WWJ, Detroit, Mich. (352.7), 6 p. m., dinner concert; S. Detroit News orchestra; Anne Campbell, poet; 9, Jean Goldkette's Victor Recording orchestra.

Central Standard Time Stations

KFAB, Lincoln, Neb. (240), 7:30-9:30 p. m., Blue Triangle club.

KFNF, Shenandoah, Ia. (266), 7:30 p. m., concert from Vales, Rev. E. W. Griffith.

KFRU, Bristow, Okla. (394.5), 8-10:30 p. m., entertainment.

KFVE, University City, Mo. (240), 6 p. m., Radioeast review of theaters, Romaine Fielding; 10, thirty minutes of fun, Jack; request numbers, KFVE studio artists, Marty, Steve, Lee, Dave, Ted, Three Spooks.

KSD, St. Louis, Mo. (545.1), 7 p. m., Lyric Skydome, Silverman's orchestra.

KTHS, Hot Springs National Park, Ark. (374.8), 8:30-8:40 p. m., baseball; 8:40, New Arlington Hotel Meyer Davis ensemble.

WBAP, Fort Worth, Texas (475.9), 7:30-8:30 p. m., musical program; 9:30-10:45, Fred Cahoon's Texas hotel dance orchestra.

WCCO, Minneapolis-St. Paul, Minn. (416.4), 6 p. m., baseball; 7, midweek church service, Gloria Dei Lutheran church; Rev. E. E. Ryden, pastor; 8:30, University of Minnesota program; 9, baseball; 10:30, George Osborn's Original Nicollel hotel orchestra; 11:30, Eddie Dunstedter, organist.

WDAF, Kansas City, Mo. (365.6), 6-7 p. m., piano tuning-in number on the Duo-Art; speaker, auspices

Health Conservation association; address, speaker, Meat Council of Greater Kansas City; Tell-Me-a-Story Lady; Plantation players; 8-10, Star's Radio orchestra; 11:45-1, Merry Old Chief, Carl Nordberg's Plantation players; Charles Dornberger's Kansas City Athletic club orchestra.

WHA, Madison, Wis. (335.4), 8 p. m., University School of Music; "Franklin's Captive Spark and Modern Radio," Prof. E. M. Terry.

WHAS, Louisville, Ky. (399.8), 3:15 p. m., baseball; 7:30-9 p. m., string division, K. & I. Terminal Railroad orchestra; University of Louisville banjo quartet.

WHO, Des Moines, Ia. (526), 6:30-7:30 p. m., Heese-Hughes orchestra; 7:30-9, Cleveland Six program; 9-9:45, Des Moines theater symphony orchestra; 9:45-11, Cleveland Six dance program.

WOAN, Lawrenceburg, Tenn. (282.8), 12:15-12:45 p. m., Vaughan Radio orchestra; 9-10, Vaughan Radio orchestra; male quartet.

WOC, Davenport, Iowa (483.6), 6:50-7:10 p. m., "Children and Their Training," C. I. Dawdy; 9-10, musical program.

WSB, Atlanta, Ga. (428.3), 5-6 p. m., Bonnie Barnhardt's bedtime story; Georgian's orchestra; 10:45 Georgian's orchestra.

WSMB, New Orleans, La. (319), 6:30-7:30 p. m., dinner music, baseball; 8:30-10:30, entertainment.

Mountain Standard Time Stations

KOA, Denver Colo. (322.4) 8 p. m., Fred Schmitt and his Bialto theater orchestra; 8:10 "The Captain of Plymouth," comic opera; 10-12, Dave Ginsburg and his Argonaut orchestra.

Pacific Standard Time Stations
KFAE, Pullman, Wash. (348.6), 7:30-9 p. m., Mary Cameron, pianist; Doris McEynolds, violinist; "Canine Distemper," Dr. George R. Fowler; "Modern Plant Doctors," George L. Zunder; "The Lost Art of Enjoying Oneself," Rev. R. W. Graves; "Interesting Washington Crop Records," Prof. E. G. Schafer.

KFI, Los Angeles, Calif. (467), 5:30-6 p. m.,

An Evening at Home with the Listener In

STATIONS IN ORDER OF WAVE LENGTHS USED

Meters	Call	Meters	Call	Meters	Call	Meters	Call	Meters	Call	Meters	Call
226	WBBM	275	KFAU	313	CNRA	356.9	CHNC	405.2	WJY	468.5	WCAP
226	WIBO	275	KFKU	315.6	KFDM	361.2	KGO	405.2	WOR	468.5	WRC
233	WEBJ	275	WABL	315.6	WAHG	361.2	WHN	406	WBAR	475.9	WBAP
240	KFAB	275	WHAD	315.6	WGBS	365.6	WDAF	410.7	CKAC	475.9	WEEI
240	KFVE	275	WORD	319	WGR	365.6	WHB	416.4	WCCO	475.9	WFAA
240	WOAX	275.3	WJAS	319	WSMB	370	CYB	421	KIAF	480	CYL
243.8	WAMD	278	WCAU	322.4	KOA	370.2	WEBH	422.3	WLW	483.6	WOC
244	WABN	278	WLBL	325.9	WSAI	370.2	WGN	423	WSB	483.6	WSUI
250	WGES	278	WRBC	330	CYX	374.8	KTHS	428.3	WSP	491.5	KGW
250	WMBB	280.2	WNAC	333.3	WBZ	379.5	WGY	429.5	KPO	491.5	KGW
252	KFWB	280.2	WREO	336.9	KFMX	379.5	WHAZ	434.5	CNRO	491.5	WEAF
261	KFWA	285.5	WKAR	336.9	WCAL	384.4	CKY	435	NAA	499.7	WMC
261	KSL	285.5	WRBO	336.9	WSAC	384.4	KJR	435	AT9	508.2	KLX
265.5	WMAK	293.9	KJAS	340.7	WKAQ	389.4	WEAR	440.9	WDWF	508.2	WOO
266	KFNF	293.9	KJAS	340.7	WKAQ	389.4	WEAR	440.9	WOS	516.9	CJCA
266	WBCN	293.9	WBAO	344.6	WCBD	394.5	WPI	447.5	WMAQ	516.9	WCX
268	WEBW	299.8	KFMX	344.6	WLS	394.5	WLIT	447.5	WQJ	526	WHO
270	WGST	299.8	WPG	348.6	KFAE	394.5	WOAI	454.3	KFOA	526	WNYC
272.6	WBBR	302.8	WJJD	348.6	KOB	399.8	WHAS	454.3	WJZ	526	WOAW
272.6	WFBH	302.8	WTAS	348.6	WTIC	399.8	WHT	455	KTW	535.4	KYW
273	WHK	305.9	WJAR	352.7	WWJ	400	PWX	461.3	WCAE	545.1	KFUO
273	WRW	309.1	KDKA	356.9	CFCA	405.2	KHJ	467	KPI	545.1	KSD

(FOR PACIFIC TIME)

Call	Met.	Saturday	Sunday	Monday	Tuesday	Wednesday	Thursday	Friday	Met.	Call
AT9	435	Silent	3:00-4:00	Silent	Silent	Silent	5:00-7:55	Silent	435	AT9
CFCA	356.9	Silent	4:00-5:00	Silent	5:15-6:15	5:15-6:15	5:15-6:15	Silent	356.9	CFCA
CFNC	343.5	9:00-11:00	Silent	Silent	Silent	Silent	7:00-8:00	Silent	343.5	CFNC
CHNC	356.9	Silent	Silent	5:30-6:30	Silent	Silent	Silent	Silent	356.9	CHNC
CJCA	516.9	8:00-10:00	6:30-7:30	6:30-8:30	6:30-7:00	5:00-7:00	8:00-10:00	7:00-11:00	516.9	CJCA
CKAC	410.7	4:30-9:30	1:30-2:30	Silent	4:30-9:30	Silent	4:30-9:30	Silent	410.7	CKAC
CKY	384.4	Silent	5:00-6:45	Silent	5:30-8:00	Silent	6:00-7:00	5:30-8:00	384.4	CKY
CNRA	313	Silent	Silent	Silent	4:30-5:30	Silent	Silent	Silent	313	CNRA
CNRO	434.5	4:30-9:30	Silent	Silent	Silent	4:30-9:30	Silent	Silent	434.5	CNRO
CYB	370	8:15-9:45	Silent	Silent	Silent	Silent	Silent	Silent	370	CYB
CYL	480	Silent	Silent	Silent	8:00-9:30	Silent	Silent	8:00-9:30	480	CYL
CYX	330	Silent	Silent	Silent	7:15-8:30	Silent	Silent	7:15-8:45	330	CYX
KDKA	309.1	4:45-6:55	12:00-4:30	4:45-6:55	5:00-9:30	4:45-6:55	4:15-9:00	4:45-6:55	309.1	KDKA
KFAB	240	9:00-10:30	2:00-3:00	5:30-8:00	Silent	5:30-8:00	5:30-8:00	5:30-8:00	240	KFAB
KFAE	348.6	Silent	Silent	7:30-9:00	Silent	7:30-9:00	Silent	7:30-9:00	348.6	KFAE
KFAU	275	Silent	Silent	7:00-8:00	Silent	Silent	Silent	7:00-8:00	275	KFAU
KFDM	315.6	Silent	Silent	Silent	6:00-7:00	Silent	Silent	6:00-7:00	315.6	KFDM
KFI	467	6:45-11:00	4:00-11:00	6:45-12:00	6:45-12:00	6:45-12:00	6:45-12:00	6:45-12:00	467	KFI
KFKU	275	Silent	Silent	4:50-6:45	Silent	Silent	4:50-6:45	Silent	275	KFKU
KFKX	288.3	Silent	Silent	7:30-9:00	Silent	Silent	7:30-9:00	Silent	288.3	KFKX
KFMQ	299.8	Silent	Silent	Silent	7:00-8:00	Silent	5:30-6:30	Silent	299.8	KFMQ
KFMX	336.9	Silent	5:00-6:00	Silent	8:00-9:00	7:00-8:00	Silent	Silent	336.9	KFMX
KFNF	266	5:30-6:30	4:30-7:30	5:30-6:30	Silent	5:30-6:30	5:30-6:30	5:30-6:30	266	KFNF
KFOA	454.3	6:00-11:30	Silent	6:00-10:00	6:00-11:30	6:00-10:00	Silent	6:00-11:30	454.3	KFOA
KFRU	394.5	5:30-10:00	3:00-5:00	5:00-8:30	6:00-8:30	6:00-8:30	8:30-9:30	6:00-11:00	394.5	KFRU
KFUO	545.1	Silent	7:15-8:15	Silent	Silent	7:15-8:15	Silent	Silent	545.1	KFUO
KFVE	240	8:00-10:00	Silent	8:00-10:00	8:00-10:00	8:00-10:00	Silent	8:00-10:00	240	KFVE
KFWA	261	Silent	8:00-9:00	8:00-9:00	8:00-9:00	8:00-9:00	Silent	8:00-10:00	261	KFWA
KFWB	252	7:45-12:00	9:00-11:00	6:30-1:00	7:45-1:00	7:45-1:00	7:45-1:00	7:45-1:00	252	KFWB
KGO	361.2	8:00-1:00	3:30-9:00	8:00-1:00	8:00-1:00	Silent	8:00-1:00	Silent	361.2	KGO
KGW	491.5	8:00-10:00	6:00-8:00	8:00-7:00	8:00-12:00	8:00-12:00	9:00-12:00	9:00-12:00	491.5	KGW
KHJ	405.2	8:00-2:00	6:30-10:00	8:00-10:00	8:00-11:00	6:00-11:00	6:00-11:00	6:00-11:00	405.2	KHJ
KIAF	421	Silent	2:00-3:00	7:00-8:00	Silent	7:00-8:00	Silent	7:00-8:00	421	KIAF
KJR	384.4	Silent	7:00-8:00	6:00-10:00	Silent	8:30-10:00	10:30-12:00	8:30-10:00	384.4	KJR
KJS	293.9	Silent	7:15-9:30	Silent	8:00-9:00	Silent	8:00-9:00	Silent	293.9	KJS
KLX	508.2	Silent	Silent	6:00-11:00	Silent	6:00-11:30	Silent	6:00-10:30	508.2	KLX
KNX	336.9	6:30-2:00	5:00-11:00	6:30-12:00	6:30-12:00	7:00-12:00	6:30-12:00	6:30-2:00	336.9	KNX
KOA	322.4	8:00-11:00	3:30-7:30	7:00-8:00	Silent	7:00-11:00	Silent	7:00-8:00	322.4	KOA
KOB	348.6	Silent	Silent	6:30-7:30	Silent	Silent	Silent	6:30-7:30	348.6	KOB
KPO	428.3	6:25-12:00	6:30-10:00	6:30-11:00	6:30-11:00	6:30-11:00	6:30-11:00	6:30-11:00	428.3	KPO
KSD	545.1	5:00-7:30	Silent	5:30-9:00	4:00-9:00	5:00-6:00	Silent	6:30-8:00	545.1	KSD
KSL	261	7:00-10:00	8:00-10:00	7:00-10:00	7:00-10:00	7:00-10:00	7:00-10:00	8:00-10:00	261	KSL
KTHS	374.8	6:30-7:45	6:30-9:30	6:30-9:00	6:30-8:45	6:30-8:45	6:30-8:45	6:30-8:45	374.8	KTHS
KTW	455	Silent	7:00-9:30	Silent	Silent	Silent	Silent	Silent	455	KTW
KYW	535.4	4:00-10:30	1:00-5:00	Silent	4:00-8:30	4:00-10:30	4:00-8:30	4:00-10:30	535.4	KYW
NAA	434.5	Silent	Silent	4:45-5:00	4:45-5:00	4:25-5:40	4:45-5:00	4:45-5:00	434.5	NAA
PWX	400	5:30-8:00	Silent	Silent	Silent	5:30-8:00	Silent	Silent	400	PWX
WABL	275	Silent	Silent	4:00-6:00	Silent	4:00-6:00	Silent	4:00-6:00	275	WABL
WABN	244	Silent	Silent	7:00-10:00	Silent	Silent	7:00-10:00	Silent	244	WABN
WAGD	315.6	9:00-11:00	Silent	4:00-10:00	Silent	3:30-8:00	Silent	4:00-7:30	315.6	WAGD
WAMG	243.8	8:00-9:00	12:00-8:00	Silent	8:00-9:00	8:00-9:30	8:00-9:30	8:00-9:00	243.8	WAMG
WBAP	475.9	5:00-6:00	9:00-10:00	5:30-11:00	5:30-8:45	5:30-8:45	5:30-8:45	5:30-8:45	475.9	WBAP
WBAR	406	Silent	8:00-9:00	7:00-8:00	Silent	6:00-7:00	5:30-6:30	Silent	406	WBAR
WBAV	293.9	Silent	5:00-7:00	5:00-7:00	Silent	Silent	Silent	5:00-6:00	293.9	WBAV
WBBM	226	5:00-10:00	1:00-7:00	Silent	5:00-9:00	5:00-7:00	5:00-9:00	5:00-7:00	226	WBBM
WBBR	272.6	4:00-4:45	5:00-6:05	4:00-4:50	Silent	Silent	4:00-4:50	Silent	272.6	WBBR
WBCN	266	6:00-10:00	2:00-9:00	Silent	6:00-12:00	5:00-9:00	6:00-11:00	6:00-10:00	266	WBCN
WBZ	333.3	3:30-5:55	3:00-6:00	Silent	3:30-5:55	3:30-7:05	3:30-8:45	Silent	333.3	WBZ
WCAE	461.3	4:00-5:30	Silent	4:30-8:00	4:30-7:00	4:30-7:30	4:00-7:00	4:30-5:30	461.3	WCAE
WCAL	336.9	10:00-11:00	6:30-8:00	9:00-10:00	Silent	Silent	7:00-8:00	6:30-7:00	336.9	WCAL
WCAP	468.5	Silent	1:00-7:00	4:00-8:30	Silent	3:00-9:00	Silent	4:30-9:00	468.5	WCAP
WCAU	278	Silent	1:00-3:00	Silent	3:20-7:30	3:00-7:10	Silent	3:30-6:40	278	WCAU
WCBD	344.6	Silent	6:00-7:00	5:00-7:30	Silent	Silent	5:00-7:30	Silent	344.6	WCBD
WCCO	416.4	6:00-9:00	5:45-8:15	4:00-9:00	4:00-7:00	4:00-9:30	4:00-8:00	4:00-10:00	416.4	WCCO
WCX	516.9	Silent	Silent	3:00-6:30	3:00-8:00	3:00-6:30	Silent	3:00-8:00	516.9	WCX
WDAF	365.6	4:00-11:00	2:00-3:30	4:00-11:00	4:00-11:00	4:00-11:00	4:00-11:00	4:00-11:00	365.6	WDAF
WDWF	440.9	Silent	1:00-2:45	Silent	4:30-5:30	Silent	Silent	2:00-8:30	440.9	WDWF
WEAF	491.5	2:00-8:00	3:20-6:15	2:00-7:30	2:00-8:00	2:00-8:00	2:00-8:00	2:00-8:00	491.5	WEAF
WEAO	293.9	Silent	Silent	Silent	Silent	5:00-6:00	5:00-6:00	Silent	293.9	WEAO
WEAR	389.4	Silent	6:00-7:00	4:00-5:00	4:00-8:00	3:45-4:45	4:00-8:00	4:00-8:00	389.4	WEAR
WEBB	370.2	4:30-9:30	4:00-6:00	Silent	4:30-9:30	4:30-9:30	4:30-9:30	4:30-9:30	370.2	WEBB
WEBJ	233	Silent	Silent	Silent	4:00-5:00	3:00-5:00	Silent	4:00-5:00	233	WEBJ
WEBW	268	Silent	2:25-3:30	6:30-7:45	6:30-7:45	Silent	Silent	Silent	268	WEBW
WEEI	475.9	Silent	3:20-6:20	4:00-7:00	4:00-7:00	4:00-7:00	4:00-7:00	4:00-7:00	475.9	WEEI
WFAA	475.9	6:30-10:00	4:00-9:00	4:30-7:30	4:30-7:30	4:30-10:00	4:30-7:00	4:30-7:00	475.9	WFAA
WFBH	272.6	7:30-10:00	1:00-4:00	7:30-10:00	7:30-10:00	7:30-10:00	7:30-10:00	7:30-10:00	272.6	WFBH
WFI	394.5	4:00-7:00	Silent	Silent	4:00-6:00	Silent	4:00-7:00	Silent	394.5	WFI
WGBS	315.6	2:00-8:00	5:30-6:30	Silent	2:00-8:00	Silent	2:00-9:00	Silent	315.6	WGBS
WGES	250	7:30-11:00	7:30-11:00	Silent	7:30-11:00	7:30-11:00	7:30-11:00	7:30-11:00	250	WGES
WGN	370.2	3:30-8:30	6:00-7:00	Silent	3:30-8:30	3:30-8:30	3:30-8:30	3:30-8:30	370.2	WGN
WGR	319	Silent	3:15-4:30	4:30-7:30	4:30-7:00	4:00-7:00	4:00-7:00	4:45-7:00	319	WGR
WGST	270	Silent	Silent	7:00-8:00	Silent	Silent	5:00-6:00	Silent	270	WGST
WGY	379.5	6:30-9:00	5:30-8:00	3:30-5:30	4:30-9:30	Silent</				

An Evening at Home with the Listener In

(FOR CENTRAL TIME)

(Tabular form and listings copyrighted. Reproduction is forbidden.)

(FOR EASTERN TIME Or Cities Using Central Daylight Saving Time)

Call	Saturday	Sunday	Monday	Tuesday	Wednesday	Thursday	Friday	Call	Location	Met.	Saturday	Sunday	Monday	Tuesday	Wednesday	Thursday	Friday	Call	
AT9	Silent	5:00-6:00	Silent	Silent	Silent	7:00-8:55	Silent	AT9	Fort Bragg, N. C.	435	Silent	6:00-7:00	Silent	Silent	Silent	8:00-9:55	Silent	AT9	
CFCA	Silent	6:00-7:00	Silent	7:15-8:15	7:15-8:15	7:15-8:15	Silent	CFCA	Toronto, Ont.	356.9	Silent	7:00-8:00	Silent	8:15-9:15	8:15-9:15	10:00-11:00	Silent	CFCA	
CFNC	11:00-1:00	Silent	Silent	Silent	Silent	9:00-10:00	Silent	CFNC	Calgary, Alta.	434.5	12:00-2:00	Silent	Silent	Silent	Silent	Silent	Silent	CFNC	
CHNC	Silent	7:30-8:30	Silent	Silent	Silent	Silent	Silent	CHNC	Toronto, Ont.	356.9	Silent	8:30-9:30	Silent	Silent	Silent	Silent	Silent	CHNC	
CJCA	10:00-12:00	8:30-9:30	8:30-9:30	8:30-9:00	7:00-9:00	10:00-12:00	9:30-12:00	CJCA	Edmonton, Can.	516.9	9:00-11:00	9:30-11:30	9:30-10:00	9:30-10:00	9:30-10:00	11:00-1:00	10:30-1:00	CJCA	
CKAC	5:30-9:30	Silent	Silent	5:30-9:30	8:00-9:00	6:30-7:30	7:30-10:00	CKAC	Montreal, Que.	410.7	6:30-10:30	Silent	Silent	6:30-10:30	8:00-10:00	7:30-8:30	8:30-11:00	CKAC	
CKY	Silent	7:00-8:45	Silent	7:30-10:00	Silent	8:00-9:00	7:30-10:00	CKY	Winnipeg, Man.	384.4	Silent	8:00-9:45	Silent	8:30-11:00	Silent	9:00-10:00	8:30-11:00	CKY	
CNRA	Silent	Silent	Silent	6:30-7:30	Silent	Silent	6:30-7:30	CNRA	Moncton, Can.	313	Silent	Silent	Silent	Silent	Silent	7:30-8:30	7:30-8:30	CNRA	
CNRO	6:30-11:30	Silent	Silent	6:30-11:30	6:30-11:30	Silent	Silent	CNRO	Ottawa, Ont.	434.5	7:30-12:30	Silent	Silent	Silent	Silent	Silent	Silent	CNRO	
CYB	10:30-11:45	Silent	Silent	9:15-10:15	Silent	Silent	Silent	CYB	Mexico City, Mex.	370	11:30-12:45	Silent	Silent	10:15-11:15	Silent	Silent	Silent	Silent	CYB
CYL	Silent	Silent	Silent	10:00-11:30	Silent	Silent	10:00-11:30	CYL	Mexico City, Mex.	480	Silent	Silent	Silent	11:00-12:30	Silent	Silent	11:00-12:30	CYL	
CYX	Silent	Silent	9:15-10:30	Silent	Silent	Silent	Silent	CYX	Mexico City, Mex.	330	Silent	Silent	10:15-11:30	Silent	Silent	Silent	10:15-11:45	CYX	
KDKA	6:45-8:55	2:00-6:30	6:45-8:55	7:00-11:30	6:45-8:55	6:15-11:00	6:45-8:55	KDKA	Pittsburgh, Pa.	309.1	7:45-9:55	3:00-7:30	7:45-9:55	8:00-12:30	7:45-9:55	7:15-12:00	7:45-9:55	KDKA	
KFAB	11:00-12:30	4:00-5:00	7:30-10:00	Silent	7:30-10:00	Silent	7:30-9:30	KFAB	Lincoln, Nebr.	240	12:00-1:30	5:00-6:00	8:30-11:00	Silent	8:30-11:00	8:30-10:30	8:30-10:30	KFAB	
KFAE	Silent	Silent	9:30-11:00	Silent	9:30-11:00	Silent	Silent	KFAE	Pullman, Wash.	348.6	Silent	Silent	10:30-12:00	Silent	10:30-12:00	Silent	10:30-12:00	KFAE	
KFAU	Silent	Silent	9:00-10:00	Silent	9:00-10:00	Silent	9:00-10:00	KFAU	Boise, Idaho	275	Silent	Silent	10:00-11:00	Silent	Silent	Silent	10:00-11:00	KFAU	
KFDM	Silent	Silent	Silent	8:00-9:00	Silent	Silent	8:00-9:00	KFDM	Beaumont, Texas	315.6	Silent	Silent	Silent	9:00-10:00	Silent	Silent	9:00-10:00	KFDM	
KFI	8:45-1:00	6:00-1:00	8:45-2:00	8:45-2:00	8:45-2:00	8:45-1:00	8:45-2:00	KFI	Los Angeles, Calif.	467	9:45-2:00	7:00-2:00	9:45-3:00	9:45-3:00	9:45-3:00	9:45-3:00	9:45-3:00	KFI	
KFKU	Silent	Silent	6:50-8:45	Silent	Silent	6:50-8:45	Silent	KFKU	Lawrence, Kan.	275	Silent	Silent	Silent	Silent	Silent	7:50-9:45	7:50-9:45	KFKU	
KFKX	Silent	Silent	9:30-11:00	Silent	9:30-11:00	9:30-11:00	Silent	KFKX	Hastings, Nebr.	288.3	Silent	Silent	10:30-12:00	Silent	Silent	10:30-12:00	Silent	KFKX	
KFMQ	Silent	Silent	Silent	9:00-10:00	Silent	7:30-8:30	Silent	KFMQ	Fayetteville, Ark.	299.8	Silent	Silent	Silent	10:00-11:00	Silent	8:30-9:30	Silent	KFMQ	
KFMX	Silent	7:00-8:00	Silent	10:00-11:00	9:00-10:00	Silent	Silent	KFMX	Northfield, Minn.	336.9	Silent	8:00-9:00	Silent	11:00-12:00	10:00-11:00	Silent	Silent	KFMX	
KFNF	7:30-8:30	6:30-9:30	7:30-8:30	Silent	7:30-8:30	7:30-8:30	7:30-8:30	KFNF	Shenandoah, Ia.	266	8:30-9:30	7:30-10:30	8:30-9:30	8:30-9:30	8:30-9:30	8:30-9:30	8:30-9:30	KFNF	
KFOA	8:00-1:30	Silent	8:00-12:00	8:00-1:30	8:00-12:00	Silent	8:30-1:30	KFOA	Seattle, Wash.	454.3	9:00-2:30	Silent	9:00-2:30	9:00-2:30	9:00-2:30	Silent	9:00-2:30	KFOA	
KFRU	7:30-12:00	5:00-7:00	7:00-10:30	Silent	8:00-10:30	10:30-11:30	11:00-1:00	KFRU	Bristow, Okla.	394.5	8:30-1:00	6:00-8:00	8:00-11:30	11:30-1:00	9:00-11:00	11:30-12:30	12:00-2:00	KFRU	
KFUD	Silent	9:15-10:15	Silent	Silent	9:15-10:15	Silent	Silent	KFUD	St. Louis, Mo.	545.1	Silent	10:15-11:15	Silent	Silent	10:15-11:15	Silent	Silent	KFUD	
KFVE	10:00-12:00	Silent	10:00-12:00	10:00-12:00	10:00-12:00	10:00-12:00	10:00-12:00	KFVE	University City, Mo.	240	11:00-1:00	Silent	11:00-1:00	11:00-1:00	11:00-1:00	11:00-1:00	11:00-1:00	KFVE	
KFWA	Silent	10:00-11:00	10:00-11:00	10:00-11:00	10:00-11:00	10:00-11:00	10:00-11:00	KFWA	Ogden, Utah	261	11:00-12:00	11:00-12:00	11:00-12:00	11:00-12:00	11:00-12:00	11:00-12:00	11:00-12:00	KFWA	
KFWB	9:45-2:00	11:00-1:00	9:30-3:00	9:45-3:00	9:45-3:00	9:45-3:00	9:45-3:00	KFWB	Hollywood, Calif.	252	10:45-3:00	12:00-2:00	10:30-4:00	10:45-4:00	10:45-4:00	10:45-4:00	10:45-4:00	KFWB	
KGO	10:00-3:00	5:30-11:00	10:00-3:00	10:00-3:00	10:00-3:00	10:00-3:00	10:00-3:00	KGO	Oakland, Calif.	361.2	11:00-4:00	6:30-12:00	11:00-4:00	11:00-4:00	11:00-4:00	11:00-4:00	11:00-4:00	KGO	
KGW	8:00-12:00	8:00-10:00	8:00-10:00	8:00-10:00	8:00-10:00	8:00-10:00	8:00-10:00	KGW	Portland, Ore.	491.5	9:00-1:00	9:00-11:00	9:00-11:00	9:00-11:00	9:00-11:00	9:00-11:00	9:00-11:00	KGW	
KHJ	8:00-4:00	8:30-12:00	10:00-12:00	8:00-1:00	8:00-1:00	8:00-1:00	8:00-1:00	KHJ	Los Angeles, Calif.	405.2	9:00-5:00	9:30-1:00	11:00-1:00	9:00-2:00	9:00-2:00	9:00-2:00	9:00-2:00	9:00-2:00	KHJ
KIAF	Silent	4:00-5:00	9:00-10:00	8:00-12:00	9:00-10:00	12:30-2:00	10:30-12:00	KIAF	Sihtipok, Minn.	421	Silent	3:00-4:00	8:00-9:00	Silent	8:00-9:00	Silent	8:00-9:00	KIAF	
KJR	Silent	9:00-10:00	8:00-12:00	10:00-11:00	8:00-12:00	10:00-11:00	8:00-12:00	KJR	Seattle, Wash.	384.4	11:30-1:00	10:00-11:00	9:00-1:00	11:30-1:00	11:30-1:00	11:30-1:00	11:30-1:00	KJR	
KJS	Silent	9:15-11:30	Silent	Silent	8:00-1:30	Silent	Silent	KJS	Los Angeles, Calif.	293.9	Silent	10:15-12:30	Silent	11:00-12:00	Silent	11:00-12:00	Silent	KJS	
KLX	Silent	Silent	8:30-1:00	8:30-2:00	8:00-2:00	8:00-2:00	8:00-2:00	KLX	Oakland, Calif.	508.2	Silent	Silent	9:00-2:00	9:00-2:00	9:00-2:00	9:00-2:00	9:00-2:00	KLX	
KNX	8:30-4:00	7:00-1:00	8:30-2:00	8:30-2:00	8:00-2:00	8:00-2:00	8:00-2:00	KNX	Hollywood, Calif.	336.9	9:30-5:00	8:00-2:00	9:30-3:00	9:30-3:00	9:30-3:00	9:30-3:00	9:30-3:00	KNX	
KOA	10:00-1:00	5:30-9:30	9:00-10:00	Silent	9:00-1:00	Silent	Silent	KOA	Denver, Colo.	322.4	11:00-2:00	6:30-10:30	10:00-11:00	10:00-2:00	10:00-2:00	10:00-2:00	10:00-2:00	KOA	
KOB	Silent	Silent	8:30-3:00	Silent	Silent	8:30-1:00	8:30-1:00	KOB	State College, N. M.	348.6	Silent	Silent	9:30-10:30	Silent	Silent	9:30-10:30	9:30-10:30	KOB	
KPO	8:25-2:00	8:30-12:00	8:30-1:00	8:30-1:00	8:30-1:00	8:30-1:00	8:30-1:00	KPO	San Francisco, Calif.	428.3	9:25-3:00	9:30-1:00	9:30-2:00	9:30-2:00	9:30-2:00	9:30-2:00	9:30-2:00	KPO	
KSD	7:00-9:30	Silent	7:30-11:00	6:00-11:00	7:00-8:00	Silent	7:30-10:00	KSD	St. Louis, Mo.	545.1	8:00-10:30	Silent	8:30-12:00	7:00-12:00	8:00-9:00	8:00-9:00	8:00-11:00	KSD	
KSL	9:00-12:00	10:00-12:00	9:00-12:00	10:00-12:00	9:00-12:00	9:00-12:00	9:00-12:00	KSL	Salt Lake City, Utah	261	10:00-1:00	11:00-1:00	10:00-1:00	11:00-1:00	10:00-1:00	10:00-1:00	11:00-1:00	KSL	
KTHS	8:30-9:45	8:30-11:30	8:30-11:00	8:30-10:45	8:30-10:45	8:30-10:45	8:30-10:45	KTHS	Hot Springs, Ark.	374.8	9:30-10:45	9:30-12:30	9:30-12:00	9:30-12:00	9:30-11:45	9:30-11:45	9:30-11:45	9:30-11:45	KTHS
KTW	Silent	9:00-11:30	Silent	Silent	9:00-10:00	Silent	Silent	KTW	Seattle, Wash.	455	Silent	10:00-12:30	Silent	Silent	Silent	Silent	Silent	KTW	
KYW	6:00-12:30	3:00-7:00	Silent	6:00-10:30	6:00-12:30	6:00-12:30	6:00-12:30	KYW	Chicago, Ill.	535.4	7:00-1:30	4:00-8:00	Silent	Silent	7:00-1:30	7:00-1:30	7:00-1:30	7:00-1:30	KYW
NAA	Silent	Silent	6:45-7:00	6:45-7:00	6:45-7:00	6:45-7:00	6:45-7:00	NAA	Radio, Va.	434.5	Silent	Silent	7:45-8:00	7:45-8:00	7:45-8:00	7:45-8:00	7:45-8:00	NAA	
PWX	7:30-10:00	Silent	Silent	Silent	7:30-10:00	Silent	Silent	PWX	Havana, Cuba	400	8:30-11:00	Silent	Silent	8:30-11:00	8:30-11:00	8:30-11:00	8:30-11:00	PWX	
WABL	Silent	Silent	6:00-8:00	Silent	6:00-8:00	6:00-8:00	6:00-8:00	WABL	Storrs, Conn.	275	Silent	Silent	7:00-9:00	Silent	7:00-9:00	7:00-9:00	7:00-9:00	WABL	
WABN	Silent	Silent	9:00-12:00	Silent	9:00-12:00	9:00-12:00	9:00-12:00	WABN	La Crosse, Wis.	244	Silent	Silent	10:00-1:00	Silent	10:00-1:00	10:00-1:00	10:00-1:00	WABN	
WAHG	11:00-1:00	Silent	6:00-12:00	Silent	6:00-12:00	6:00-12:00	6:00-12:00	WAHG	Richmond, N. Y.	315.6	12:00-2:00	Silent	7:00-1:00	Silent	6:30-11:00	Silent	7:00-10:30	WAHG	
WAMD	10:00-11:00	2:00-10:00	Silent	10:00-11:00	10:00-11:00	10:00-11:00	10:00-11:00	WAMD	Minneapolis, Minn.	243.8	11:00-12:00	3:00-11:00	11:00-12:00	11:00-12:00	11:00-12:00	11:00-12:00	11:00-12:00	WAMD	
WBAP	7:00-8:00	11:00-12:00	7:30-1:00	7:30-10:45	7:30-10:45	7:30-10:45	7:30-10:45	WBAP	Fort Worth, Tex.	475.9	8:00-9:00	12:00-1:30	8:30-2:00	8:30-11:45	8:30-11:45	8:30-11:45	8:30-11:45	8:30-11:45	WBAP
WBAR	Silent	10																	

Radio Digest

PROGRAMS
Illustrated

Published by the Radio Digest Publishing Company, Inc.
510 North Dearborn Street
Chicago, Illinois
Telephones: State 4372, 4373, 4374, 4375

E. C. RAYNER, Publisher

Eastern Office, Park-Lexington Building, 247 Park Ave.,
New York. Telephones: Ashland 8144, 8145, 8146

Member of the Audit Bureau of Circulations

241
PUBLISHED WEEKLY

SUBSCRIPTION RATES
Yearly in U. S. and Possessions and Canada, \$5.00
Foreign postage, \$1.00 additional. Single copies, 10 cents.

Vol. XIII Saturday, June 6, 1925 No. 9

What Makes a Good Program Director

LIKE all new industries, the broadcasting of entertainment and service has created a new series of vocations. One of the most important is that of program director. This post already has become so specialized as to achieve the dignity of a profession. It is believed that there are now nearly fifteen hundred program builders in the United States. What makes a good one?

The question is worthy of asking inasmuch as the policy of each station is often in the hands of the program director.

Persons with a good deal of the human element in them, who understand what interests the public, are best qualified for the task. Experienced newspapermen who have seen life from all angles often meet this requirement.

Showmen do not always have the broad field of observation, of understanding of people, to fill the need. Advertising men, too, are likely to be one-sided and often commercial in their views. Radio men as a rule are thinking mainly of how far their station is reaching rather than how many people it is interesting.

Of course, any member of the mentioned classes can round himself out to have the necessary broad vision, but the trained newspaperman, the editor, already understands every class of human mind and this has an advantage over the other classes from which program directors are made.

While on the subject, let us suggest that in the future we shall call these people "program editors" rather than "program directors," for their work is necessarily that of editing what is submitted for broadcasting, and often going out and getting the "reading matter" that is necessary to entertain and serve the public.

Super Summer Reception

NOW that fifteen superstations are "turning on the juice" to overcome summer irregularities in reception, and at least seven more superstations are in the process of construction and plan to be on the air within from four to six weeks, the lot of the listener during the summer of 1925 is going to be remarkably improved over, and in fact, not even to be compared to, the past two summers in which broadcasting has sprung from a dream to a necessity.

Not an idle boast is this. Listen in. You will hear—let's see—KDKA, WGY, WBZ, WEA, WOC, WLW, KFI, KGO, WSAI, KOA, WHT, WCCO, KFKX, and WCBD. They are sure because they are superpower stations. Then you are likely to hear almost a score of other stations that are putting 1,000 watts of power into the air.

Then there are at least six more superstations which will be on the air before long. These include WSB and Miami Beach with 2,500-watt sets, WJR, WLS and WJAZ with 5,000-watt sets, and KYW with a 25,000-watt transmitter. KYW's new voice, now being constructed, will be as powerful as her sister station KDKA, but of course the full 25,000 watts will not be used—at least not now.

So the 1925 summer listener has a pick of at least twenty superstations, anyone of which is capable of overcoming the difficulties of summer weather and reaching out to all parts of the country.

Don't pack away your set in moth balls—use it.

Clean Broadcast Advertising

BROADCAST advertising must be clean, else a station's audience may suffer large decreases in number. A message from the National Vigilance committee of the Associated Advertising Clubs of the World emphasizes this point. The bulletin is being sent to station directors which says:

"Before you broadcast commercial material, be sure that it is not only interesting and true, but that the advertiser is reputable.

"When you broadcast such material, tell your listeners, in advance, what they are about to hear."

We are glad that the "Truth-in-Advertising" movement has been extended to Radio. There are already many stations which could apply this policy to good advantage.

RADIO INDI-GEST

The Mark of Progress

VILLAGE BANDS HURT BY RADIO

Wailing of Fiddles Vanishes and Cornet Practice Grows
Listless as Farmers Twist Dials

BAND STANDS MAY DECAY

(News Story)

The band stands are decaying,
The Silver Cornets still,
The brass-buttoned coats are covered with mould
And gone is the ancient thrill.
The leader's baton is rusty,
No more the piccolo flights
And once again the natives can sleep—
Thank God—on Saturday nights.
(Chorus) Oh, the old grey mare, she ain't what she used to be,
She ain't what she used to be, she ain't, etc.,
Or, "When You and I Were Young, Maggie," for soprano voices.

Even at that we are willing to bet that some paint salesman will write to us in the coming week and want to know what paper that story was taken from. When he finds out he will pack his samples, limber up the beautiful lithographed catalog with the testimonials and rush forth to show the village fathers that there is no need of letting the bandstand decay, and that by saving the surface they can save all.

News Bulletins from Milwaukee

Furnished in Cooperation with the Milwaukee Daily Beverage

(Beer up, my friend, beer up)

Armin Schwartemagen (Nonp.), who conducts a soft drink parlor, runs a single circuit set. The young man made himself a public nuisance by squealing up the ether. The matter was brought to Mayor Bone's (Soc.) attention, who ordered Police Chief Baer (Soc.) to tell Sergeant Schultz (Soc.) to order Patrolman Weisskopf (Soc.) to tell Saloonist Schwartemagen to have said nuisance abated or maybe the Police Commissioner (Soc.) would perhaps have trouble to find him a soft drink parlor license this year, nicht wahr?

The Ten Commandments are showing at the Blatz theater at ten cents a commandment, the entire set \$1.50. "Du lieber Himmel," observed Mrs. Strohsack, "for why pay that when Herr Voliva chucks us more commandments every Sunday afternoon than would fill the Blatz theater."

Unveiling ceremonies of the statue of Andy Volstead, which took place recently, were Radiocast over Station WSOL. Grateful citizens have made the statue possible. "He has shortened the hours of every brewery worker in Milwaukee," said Mayor Bone, "from 50 to 100%. Formerly the men slaved 12 hours in the brewery. Now they work two hours making near beer for Chicago and then they go home and work for Milwaukee. Hurrah for prohibition, whatever that is. It has made possible for everybody to own a Radio set, automobile, player piano, private yacht, summer home on the Maine coast, or what else will you have?"

The statue is of solid bronze, all except the head, which is ivory. The inscription reads, "From 1776 to 1919." This is to denote the era of American liberty.

Station WCAY, Milwaukee's Psychic Broadcasting Station, has a right good slogan. "When you hear nothing but the generator, you're listening to WCAY."

Ottfried Wurm got both coasts on his onetubodyne last night. "Detroit was good, but, oh boy, ya shoulda heard Racine!" he avers. Up and at 'em, Ott, and lets see you bring in Zion or some other foreign station.

Have you heard the latest song from Station WBEER, Schlitz Beverage Company, "When Father drilled the bakelite with a can opener?"

Mr. Murks, the city cobbler, thought sure he had a foreign station, but found it was only Brother Erbsstein of WTAS speaking in the language of departed spirits.

Kindly ask your steno what makes this durned Remington Standard No. 10 skip when operated at my normal speed of ten and 3/4 words per minute. It ruins my otherwise perfect copy. Us authors sure got our troubles. It makes me sick.

Hoping you are the same,

THE THIRD TROMBONE PLAYER.

We always get a sense of satisfaction when we read the TROMBONE PLAYER. For a while we thought he had deserted us, but not so. On this screen next week we are prepared to present his masterpiece, "The Shooting of SingleTube McGrew." It will be illustrated, and set by Indi-Gest's most capable linotyper. Ten cents on all newsstands. (Adv.)

The Church-Goer

I must haste, I must haste,
No time will I waste,
In dressing a church full to charm.
Don't hunt for my shoe,
These bed slippers will do,
And not combing hair does no harm.

I'll not wash, it's too late,
I lack change for the plate,
And my housework is left in the lurch.
How I look, who should care,
No decorum is there,
For I'm off to the Radio church. E. M. G.

Last lines are too commonplace. Therefore we will not have one.

Wire Grass



Condensed

By DIELECTRIC

There are some refinements about broadcasting plays which are yet to appear. We have advanced somewhat since Radios first made their bow to the listening public in the matter of creating the play atmosphere. Just recently an excellent suggestion came to WGY, Schenectady, from a fan in Maine and every devotee of this station who tunes in the General Electric players will appreciate the advantage of linking a voice with a character at the outset of the play. The comedy "The Sacrifice" was ably given and easily followed throughout.

Did you happen to tune to WEAR, Cleveland, while the Western Reserve university alumni concert was in progress? If not, you missed hearing men's singing under very favorable conditions; they being: good voices, good training and entertaining songs. This station does not hesitate to present features of the better type.

Due to station interference and code, many fans living in the eastern part of the United States seldom are able to spend any part of an evening with Station KTHS, Hot Springs. They live in hopes. One of the best attractions lately offered from the station was the concert given by the 153rd Infantry band. It will bear a return engagement.

Following a vigorous day at the office, or elsewhere for that matter, it is indeed relaxing to get in tune with WSB, Atlanta, and let the announcer direct your entertainment. Those of us who had this station on a certain evening recently heard a pleasing soprano sing some of the typical southern melodies in a fascinating manner.

The time is now at hand when we can judge better whether or not increased power for our broadcast stations is worth while. To those who often tuned to KFI when that station was operating on 500 watts, the difference in strength and clarity should be quite apparent as the new transmitter is now shooting 2,000 watts nightly. One program in particular came through very fine the other evening. It was by a saxophone band of sixty pieces. After listening a while it seemed hard to realize that the same instrument so generally used to clown up in a dance orchestra is capable of being used to better advantage. That soul-stirring march, "The Stars and Stripes Forever," was very effective.

Once again I have occasion to refer to a station in Cincinnati, WLW, to congratulate them upon securing the attendance at their studio of the Formica orchestra. This body of musicians is perhaps no better than many others one might mention, but it chose a program in part presenting works of Charles Wakefield Cadman, one of America's foremost composers. The musicians had imbibed the spirit of Cadman, evidently.

From WCAP, Washington, Radio listeners recently had an offering of a girls' glee club singing numbers varying in character though not in careful presentation. The contralto voices were of very good quality and suffered no eclipse from the sopranos, as so often happens. In fact, the club was well balanced throughout and deserves commendation.

Anyone having seen as well as heard the opera "Samson and Delilah" (especially with famous artists) can close their eyes and picture the dramatic development of this opera while listening to a broadcast version. WEA, New York, presented singers with fair understanding of Saint-Saens' score.

Recent Advances in Tuned R.F. Amplification

Part II—Circuits in the 1924-5 Receivers

By Milo Gurney

BEFORE passing on to showing other than schematically, modifications and adaptation of Rice, Hartley and Hazeltine, it may prove interesting to digress a moment in calling your attention to circuit figure 7, which enjoys a marked likeness to Professor Hazeltine's circuit, the only apparent difference being the employment of a variable capacitance between the coils T1-L1 which comprise series resonant circuits. With this circuit at resonance the voltages in coils L1-L2 are in phase opposition and, by inserting T1 between the input circuit and the top of L2, compensation is accomplished. This circuit, which will be given in detail in a later article, should prove superior to either the Rice or Hazeltine method of neutralization, even though it is not a perfect compensator for wave lengths foreign to the resonance point of the coupled circuits. It, however, is easily constructed and offers much toward surprising efficiency, affording in theory a much closer counterpart of Hazeltine's regeneration limiting device than that indicated in the Rice method.

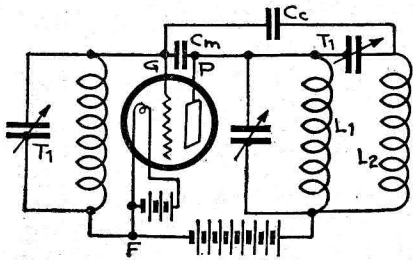

Figure 7

Reverting back to the more simple means exploited in tuned radio frequency amplifiers wherein intentional losses are deliberately inserted, either in the primaries or secondaries, to absorb undesired values of regeneration one will readily note that in each method used it is quite apparent that the designer of the circuit made no intelligent attempt

toward providing neutralization, but introduced a loss, usually in the form of a resistance, to accomplish or cover up a bad job, while often this method of resistor insertion has been used purely to dodge patent infringements. Among such means are the well known use of so-called stabilizers, high resistance transformers and potentiometers. No originality of thought is expressed in any of these adaptations, while in general, and in a

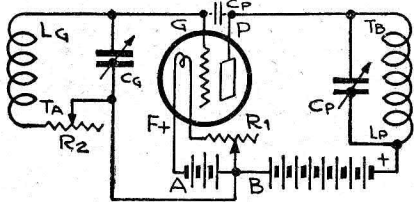

Figure 8

greater or less degree, they are harmful because, while they do function toward nullifying the effect of over inter-stage regeneration, yet in doing so their adoption trends toward causing distortion and the limitation of selectivity, each result to be avoided if possible. It would, however, be unfair to exclude a few diagrams showing some of the methods used and to advise as to which of these methods is most desirable should the experimenter desire to use them in an attempt to improve upon their application, which naturally is desirable.

Insertion of Series Resistance

Figure 8 shows a typical input and output stage of a tuned circuit as used in tuned radio frequency amplification, in which it will be noted that a series variable non-inductive resistance is inserted in the input circuit. This resistance may be of the order of 1,000 ohms, must be variable and should preferably be placed as indicated at the low potential end of such input circuit. A partial variance of this method of inserting a resistance is shown in figure 9, wherein the resistance is fixed rather than vari-

able and is placed at the high potential end of the input circuit. This method is used in the first and second stage of a well-known commercial receiver, the first stage having as its resistor value approximately 625 ohms, while the second is near the value of 600, these figures merely being given as approximate, in fairness to the manufacturer and with the further assurance that they would not hold as accurate or correct for the receiver you may construct. They are values as a guidance because the total losses essential for the securing of stabilization are quite obviously dependent upon the amount of regenerative reaction one desires to control, and varies with the maximum regenerative constants indicated as to be controlled in the completed receiver.

Shunt Resistance

Figure 10 shows a somewhat different method of loss insertion, it in effect being comparable with, and equivalent to, placing a variable shunt across the input circuit. This resistance should preferably also be variable and of the order of 1,500 to 2,000 ohms, though once the proper

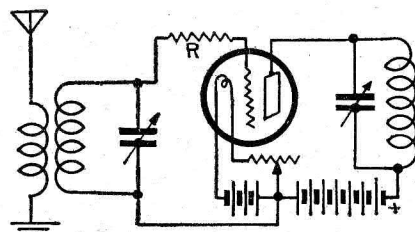

Figure 9

resistor value is determined it may be locked as constant. The variable condenser is of the standard two-plate value as it is not critical, and minimum or maximum value is not overly important. Of the two circuits, viz., 8 or 10, figure 8 is to be preferred, first because of its greater ease of construction and, secondly because the grid to filament resistance is not changed as in figure 10, hence the less likelihood of annoying distortion.

While some few experimenters have directed their efforts toward the shown insertion of resistors, both variable and fixed, in the input or grid to filament circuit, another school of thought has reversed the procedure through placing variable resistances in the output or plate circuit, some choosing their location ahead of the plate inductance or between it and the plate terminal, while others have

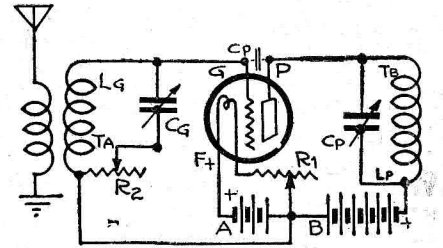

Figure 10

chosen to insert it between the plate return and the plus B battery feeding the plate. Irrespective of location, each remain as insertions of resistance and, while placing them in the plate or primary output circuit is less harmful than if they were placed in the grid or input circuit, they still remain as loss devices and do not, except in a measure, indicate a new thought or course of procedure toward the securing of ideal compensation.

They do, however, act in a measure as radio frequency chokes though evidently the thought prompting the procedure of such plate circuit resistance was to reduce the plate battery component and to at the same time accomplish this, if possible, without increasing the fundamental frequency of the primary in such a transformer.

Perhaps it is well at this point to touch upon the interesting subject of coil ratios, i. e., primary to secondary in radio frequency transformers, wherein both primary and secondary are of approxi-

(Continued on page 18)

Getting
Concerts
WHOLE

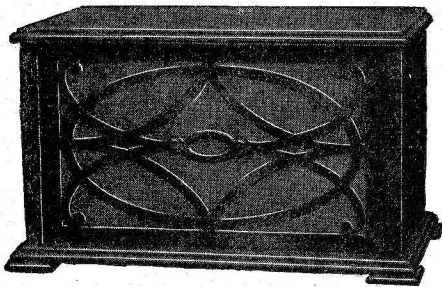

Cabinet Model "C" \$30

It soon dawns on the owner of a Bristol Speaker that he is listening in on entire concerts.

That roving disposition to tune in every station on the map is due, much more than is generally supposed, to a yearning for really sweet music.

One reason radio music does not always sound sweet is that certain of the tones are out of tune.

Coming through a Bristol Speaker, all the tones are evenly in tune. The result is an arresting sweetness that "invites" you to stay through a concert to the end.

BRISTOL AUDIOPHONE Loud Speaker

For \$25 and \$30 you can get a Bristol Speaker; and there are others as low as \$12.50. Ask your dealer to send one out. Write us for Folder No. AY-3022, telling why the Bristol is such a delight to the ear.

THE BRISTOL COMPANY, WATERBURY, CONN.



What a
Combination!



PRICE
Complete Kit
\$35

Buy Only Genuine
SHAMROCK-
HARKNESS
Licensed Parts

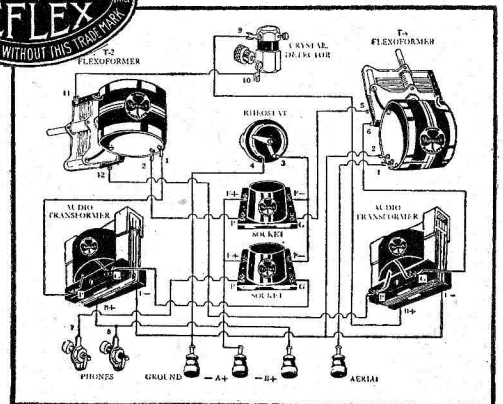
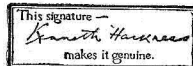

Five-Tube Volume and Distance—Reflex Clarity
Shamrock-Harkness Two-Tube Reflex

Here's a powerful little set! Two tubes do the work of five. Cuts Battery cost 60%. Gives consistent loud speaker reception within a radius of 1,000 miles—and we don't mean maybe!

This powerful little receiver is the result of months of investigation by Shamrock engineers to build the

SHAMROCK MANUFACTURING CO.
Dept. 32-C, Market St., Newark, N. J.

SHAMROCK
FOR SELECTIVE TUNING

Theset for the masses
as well as the classes

best features of the most powerful present-day circuits into one receiver—at the lowest possible cost!

Also ask to see the improved
SHAMROCK-HARKNESS
THREE-TUBE COUNTERFLEX
The wonder set \$39.50

SHAMROCK MFG. CO.,
Dept. 32-C, Market St., Newark, N. J.

I enclose 10 cents (U. S. stamps or coin) for copy of "Shamrock Radio Builder's Guide Book" containing diagrams and complete illustrations for building 10 sets at prices ranging from \$15 to \$50.

Name
Address

TUNED R.F. ADVANCES

(Continued from page 17)

mately the same gauge and of equal insulation. The major portion of such transformers keep this ratio as high as possible, the average being close to 1 to 10 while the general practice is to insert the primary inside of the form holding the secondary and to maintain a spacing of about one-quarter inch between turns of the primary. In the construction of the radio frequency transformers for some of the circuits which I will show, two very radical departures from this usual method will be shown and the logical reason given for each method used; not with the intention of joining the army of "low losers" as a buck private, but rather with hopes of attempting to advance the science instead of wrecking it with purely mechanical tricks in place of electrical goodness. Am I in favor of low loss? Never! Merely as a name, but what I am in favor of is maximum power factor, almost a new word in Radio, and I want this power factor high in the completed receiver, rather than concentrating on one spot and loosing it in the next. Possibly I should not call spades spades, but rather use the more generic term shovels; however, low losses result in the very result our leading engineers are working night and day upon and, having faith in their ability to solve the problem, let us then look to them for our greater success rather than to the clever mechanic.

Primary to Secondary Ratio

Turn ratio, or the step up ratio factor, in radio frequency transformers, in so far as believing that "the greater the ratio the greater the energy transference" has been proven as erroneous. By way of illustration, if we have six turns in the primary winding and fifty-four in the secondary winding of a solenoid type of radio frequency transformer, our turns ratio would be high, one to nine, yet our transfer or inductance value would be comparatively low. To the contrary, should we increase the number of turns to say eighteen or a step up ratio of 1 to 3, equal to a third of our former value, the amplitude of inductance transfer from primary to secondary would be at approximate maximum.

Hence, ratios, of themselves, are but relative terms and apparently have been considered too carelessly by many "low losers." Not all, by any means, as in some circuit designs and, in particular, antenna input design, turns ratio efficiency with regard to its inductance transference, is obviously and essentially high.

While this factor is equally true in inter-stage coupling upon some types of circuits, however, in general as we increase the turns ratio between primary and secondary we decrease the tendency toward creating sustained oscillations and, in direct proportion, increase the inductance transfer factor. Therefore, unless one is prepared to determine the compromise his limitations command it is best that he look upon all few turn primary, or high ratio radio frequency transformers, as devices which will tax his ingenuity toward control unless his circuit design definitely prompts their use.

Mechanical Construction

Another feature of radio frequency design common to many makes on the market for which there appears no logical reason, and which but meant additional cost to the manufacturers, and infinitely hard construction to the home builder, is the practice of placing the primary windings within or upon the inside of the tube or secondary winding.

As I write this, I have before me a radio frequency transformer so arranged as to mechanical arrangement of the entire coil that it shows clearly the maximum of mechanical ingenuity in its design and particularly, extreme cleverness and elaborate preparation for the placing of the primary inside the solenoid. With its secondary winding, it would be easily possible to present it as the finest mechanical effort in coil construction that I have seen, yet I cannot recommend it because the primary is too close to the center of the coil's magnetic field, which is another way of impressing upon you another danger point. Obviously, the ideal position would be outside of the secondary and as much out of its magnetic field as possible without destroying its inductive relation value. Therefore, in the radio frequency transformer which I shall describe later, an attempt will be made to picturize and describe a nearly standard radio frequency transformer as representing the present advanced state of the science.

(How primary cells—commonly known as all batteries other than storage—generate electricity—is Professor Moreton's next subject. The chemical actions are simply explained.—Editor's Note.)

If your ground wire runs under the carpet, you soon will notice extra wear where the wire raises the carpet. To avoid this substitute brass ribbon for the round wire.

The NEW Radio Book

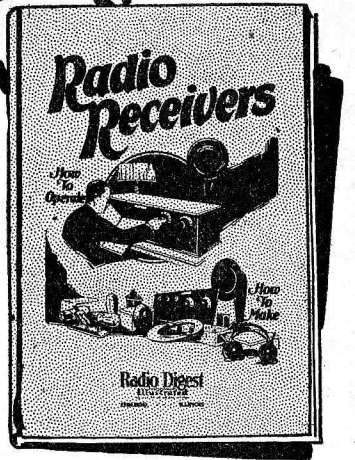

How to understand radio, assemble circuits, improve reception, operate sets,

EVERY phase of Radio reception gathered into one book at last! Explanation of elementary principles, directions for constructing parts, detailed how-to-build articles for the assembly of sets, operating directions on popular manufactured outfits.

Haven't you often wondered what all the spirals, wriggly lines and zig-zag lines were about on diagrams? A big chart shows you a picture of the part as you see it and, beside the picture, the symbol used in diagrams. Other articles show clearly just what happens within the mysterious little vacuum tubes that glow hour after hour within your set, apparently without change, yet pass every note of a jazz orchestra or soprano.

Antennas, for whose erection there are seemingly no rules, are covered fully; the reason for a long wire in some locations and a short one in others, is readily grasped by anyone. Crystal sets, one tubers, two tube reflexes, three tube regenerative and reflex outfits, four tube R. F. and neutrodynes, five tube assemblies—all types are presented up to the nine tube "super," king of the air.

For the Man That Bought His Set

For the non-technically inclined there is a two-color broadcast map of the country, operating schedules of all the leading stations, call letters and power rating of every station on the air, suggestions for the care of batteries and tubes.

No matter what type of receiver you own, there are dozens of valuable suggestions on tuning, trouble shooting and operating. Your head receivers, loud speaker, antenna and certain parts within the set, require frequent cleaning, adjusting and care. Interference and its remedies are factors you should understand even though you care nothing about "what makes it go."

Compiled by the technical staff of Radio Digest, it represents the high lights of the past twelve months in the Radio field. All this data is indexed for ready reference and logically arranged. Only a few thousand have been printed and this offer will stand for a limited time. The only book of its kind and is FREE with one year's subscription to Radio Digest. This offer good only on subscriptions sent directly to this office, not through agents or agencies.

Subscription Department

Radio Digest

510 N. Dearborn St., Chicago, Ill.

free

Radio Digest 6-6-25
 Enclosed is \$5.00 in () M. O., () Check, () Currency, for which enter my subscription to Radio Digest for one year and send me the book, "Radio Receivers."
 Name
 Address
 (Typewrite or Print Clearly)

The "Goode" Two-o-One

A

Le Ton d'argent

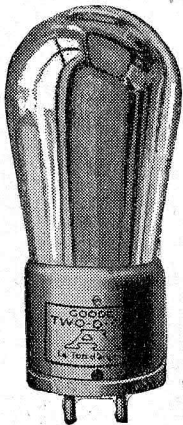

Guaranteed

BY MAIL ONLY

\$1.89

Postpaid

QUARTER AMPERE AMPLIFIER—DETECTOR

RADIO TUBE

GUARANTEED SATISFACTORY

All "GOODE" Tubes Sold Direct to the Consumer—No Dealer Profits

- ONE—"Goode" Detector-Amplifier.....\$1.89
 - THREE—"Goode" Detector-Amplifiers..... 5.00
- (All postage prepaid)

The "Goode" Two-o-One A Tube amplifies or detects. It is a quarter ampere, five volts, standard base silvered tube.
 Send express or postal money order—New York draft—or personal check to—

The Goode Tube Corporation

Owensboro (Dept. A) Kentucky

CROSLEY 1 TUBE-50

\$14.50



The Little Giant of Radio Coast to Coast Reception with phones frequently reported.

Distance

on the phones—with certainty and regularity—on the Crosley one-tube 50. The radio which told the world that the MacMillan North Pole expedition was safe and sound. The radio that kept communication open to Leonard Weeks at Minot, N. D., when all other receivers failed.

There is nothing better than the Crosley 50 for the radio beginner.

There is nothing to excel it in value; unless it be the larger Crosley sets.

Stations always come in at the same place.

For sale by good dealers everywhere. Other models priced from the two tube 51, at \$18.50, to the Trirdyn Special with sloping panel, at \$65. All Crosley Radios are licensed under Armstrong Regenerative U. S. Patent No. 1,113,149. Prices quoted are without accessories.

Prices West of Rockies—Add 10%
 Write for Complete Catalog

The Crosley Radio Corporation
 Powell Crosley, Jr., President
 6491 Sassafras St. Cincinnati, Ohio
 Crosley owns and operates Broadcasting Station WLW

A. B. C. Course in Radio Fundamentals

Chapter XI—Electrical Measuring Instruments (Part 2)

By David Penn Moreton

THE fundamental principle of the electro-dynamometer type of ammeter is shown in figure 53. The current to be measured is sent through two coils, C_1 , C_2 , connected in series. One of the coils, C_1 , is mounted on bearings so that it may turn inside of the other coil, C_2 . Two coil springs, SS, control the position of the movable coil and at the same time provide an electrical connection to it. Now, when there is a current in the ammeter, the following conditions will exist. There will be a magnetic field produced inside of the stationary coil whose strength will vary directly as the value of the current in the coil. As a result of there being a current in the movable coil, and since it is in a magnetic field, there will be a force acting on the coil which will cause it to rotate against the force due to the springs. The coil will come to rest in a position such that the force due to the action of the current will be exactly equal to the force due to the springs. The deflecting force, or the force which moves the coil from its zero position, varies in value with the value of the current in the movable coil and the strength of the magnetic field inside the stationary coil, which in turn varies in value with the current in this coil, which is the same as the current in the movable coil, or, the deflecting force will vary in value with the product of the current in the stationary coil and the current in the movable coil or, the current squared. The scale of the instruments, however, are usually marked to read the current directly.

Direction of Current No Worry

An instrument of this kind will always deflect in the same direction when there is a current sent through it, regardless of the direction of the current. When the current is reversed in direction, there is a reversal of direction of the magnetic field within the stationary coil and at the same time there is a reversal of current in the movable coil and this double reversal results in the force acting on the movable coil remaining unchanged in direction.

When an instrument of this kind is

used in measuring direct current, the deflection of the pointer may be different with the current in one direction than it is with the current in the reverse direction, although the value of the current is exactly the same in both cases. This difference in deflection is due to the action of any magnetic field, other than the magnetizing action of the current in the instruments, which may exist in the region in which the instrument is located. Such magnetic fields usually produce a

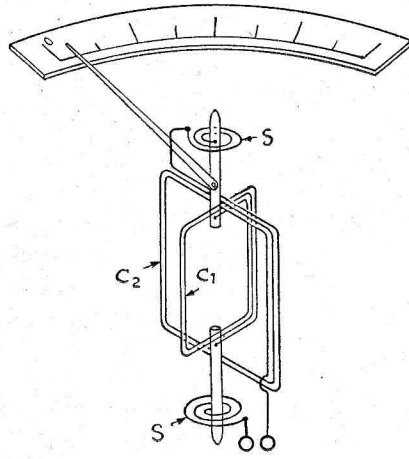

Figure 53

different effect with the current in one direction than they produce with the current in the reverse direction, which accounts for the difference in deflection. When an alternating current is being measured, the effect of any outside magnetic fields is to increase the deflection for one alternation of the current and to decrease the deflection an equal amount for an alternation in the opposite direction so that the actual or average deflection is independent of the effect of the outside magnetic fields.

Of course, when the outside magnetic

fields vary in value and direction at the same frequency as the current in the instrument, then their effect is not neutralized by the reversal of current and they cause an error in the indication of the instrument.

The fundamental principle upon which another type of ammeter, known as the "magnetic vane" or "soft iron" type, operates, may be explained by reference to figure 54. A coil C carries the current to be measured, and this coil is mounted in an inclined position. A piece of soft sheet iron I is mounted on a shaft T, which is in turn mounted in a vertical position inside the coil C. A spring S holds the pointer P, which is attached to the shaft T, in its zero position. The piece of iron I is mounted on the shaft T with its planes making an angle of something like 45 degrees to the shaft and almost parallel to the plane of the coil, when the pointer is in its zero position. Now when there is a current in the coil, a magnetic field will be produced within the coil and the piece of soft iron will be magnetized, and as a result there will be a force acting on the piece of iron tending to turn it so that its longest dimension is parallel to the axis of the coil. The value of this force will, of course, depend upon the value of the current in the coil, increasing with an increase in current and decreasing with a decrease in the current. The direction of the current in the coil has nothing to do with the direction of the force because the polarity of the piece of iron changes when the current is reversed and the deflecting force will have the same direction.

What Happens with Direct Current

When an instrument of this kind is used to measure a direct current, the deflection may be influenced by stray magnetic fields as explained in the case of the electro-dynamometer type of instruments. The magnetism in the piece of iron lags behind the current and this will cause the instrument to indicate lower values than it should when the current in

increasing, and, likewise, higher values when the current is decreasing.

An ammeter is always connected in series in the circuit in which the current is to be measured, and in order that the introduction of the instrument into the circuit may produce as small an effect as possible, the resistance of the instrument should be very small in comparison to the resistance of the remainder of the circuit. A high resistance ammeter would not only produce a noticeable

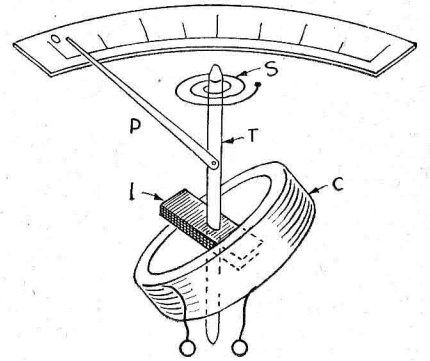

Figure 54

change in the total resistance of the circuit and hence the values of the current, but there would be a large loss in the high resistance ammeter in comparison to the loss that would occur in the low resistance instruments.

Use of Ammeter Shunts

When small currents are to be measured the total current passes through the coil or coils of the instruments. These coils and the electrical connections to them would be very cumbersome if they were made large enough to handle heavy currents, and in such cases use is made of what is called an ammeter shunt. The connection of the ammeter shunt is

(Continued on page 20)

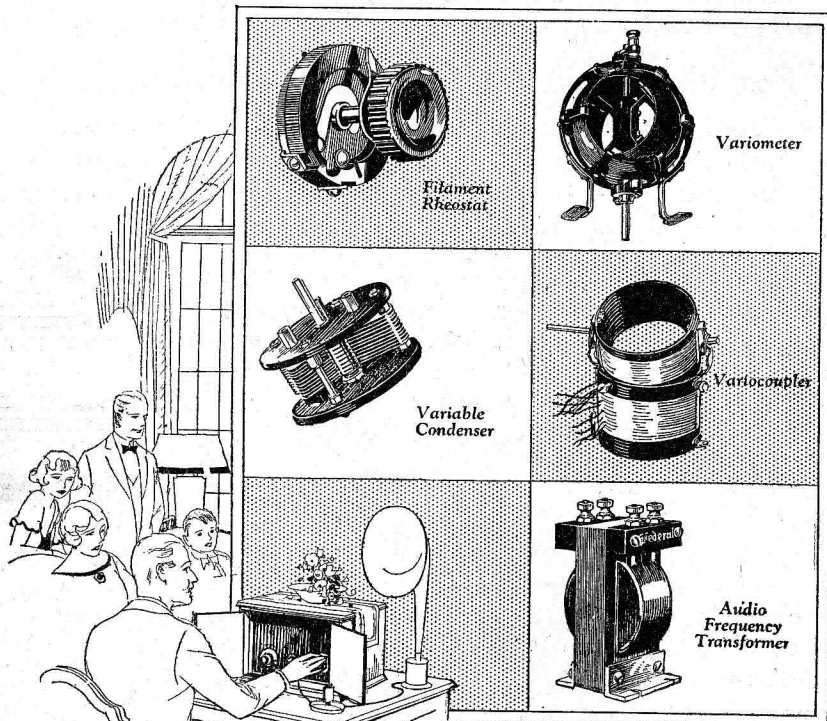

Quality Parts Matched for Perfect Teamwork

Your "pet" hook-up needs first quality parts—perfectly matched—to give you real radio.

Every Federal Standard Radio Part is designed, made, matched and guaranteed by Federal. That is why you find Federal parts in all the better hook-ups—that is why you should insist on Federal parts when purchasing.

FEDERAL TELEPHONE MANUFACTURING CORP
Buffalo, N. Y.



Federal

Standard RADIO Products



Summer Static

Now overcome by Volume!

Enjoy Radio All the Year Around--This Way!

HOW often have you heard it said, "Well, the warm weather is coming on, I had better put my radio on the shelf. It will be of no use until Fall."

There is absolutely no way to eliminate all static from your radio reception, but today there is a way to reduce it to a point where it ceases to annoy.

This new way to overcome static is by volume. And volume can best be obtained by using transformers that will amplify weak signals to their greatest strength.

Here are the Kellogg audio and radio frequency transformers. Kellogg Transformers give volume with clarity of tone.

The Kellogg radio frequency transformer is of the low-loss, high-efficiency type, incorporating important new features. It will operate at all

broadcast wavelengths with standard .00035 to .0005 variable condenser. For best results, however, we recommend the Kellogg .0005 low-loss variable condenser. Kellogg R.F. Transformers at all radio dealers—\$2.35 each.

Kellogg audio frequency transformers give maximum volume with clear reproduction. They will build up the volume of any receiving set. This is due to the high quality materials used, expert workmanship employed and the special Kellogg process of manufacture. Kellogg audio frequency transformers are made in both shielded and unshielded types ranging in price from \$3.50 to \$4.50.

Kellogg transformers may be obtained at all radio dealers.

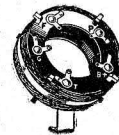

Kellogg Radio Frequency Transformer



Kellogg Audio Frequency Transformer

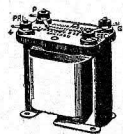

KELLOGG SWITCHBOARD & SUPPLY CO.

1066 W. Adams St., Chicago, Illinois

A. B. C. RADIO COURSE

(Continued on page 19)

shown in figure 55. The shunt is a very low resistance and the greater part of the current in the circuit passes through the shunt and only a small part of the current passes through the instrument I. The indication of the instrument I is, of course, due to the current through it, and if the relation of this current to the current through the shunt is known the total current in the main circuit may be determined by multiplying the indication of the instrument I by a constant. The scale on the instrument may be marked to read the current in the main circuit and in such a case there is no need of a constant. In the use of an ammeter shunt the division of the total current between the shunt and the instrument must be known and the division of this current is not the same for direct current as it may be for an alternating current, unless the electrical characteristics of the shunt and the instrument are identical.

A voltmeter is an instrument used to measure the difference in the electrical pressure between the two points on an electrical circuit to which its two terminals are connected. For example, in figure 56, the voltmeter V is connected to the terminals of the resistance R and

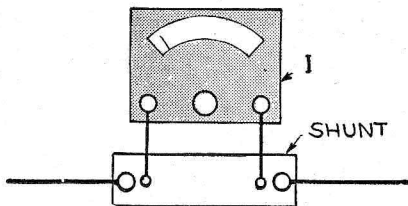

Figure 55

will give an indication of the value of the electrical pressure between the terminals of the resistance. The ammeter A will indicate the current in the main circuit, which will be practically the same as the current in the resistance R, provided the voltmeter takes a very small current.

A voltmeter depends for its operation upon some effect produced by an electrical current, just as in the case of the ammeter, and the only difference in their construction is that the voltmeter has a comparatively high resistance and the ammeter a comparatively low resistance. The deflection of the moving element of

the voltmeter depends upon the current through the instrument, and, if the resistance of the instrument is constant, this current will vary in value as the electrical pressure between the terminals of the instrument changes.

A voltmeter may be constructed so that a full scale deflection of the pointer will be produced by several different voltages. For example, the resistance of a certain voltmeter may be such that an electrical pressure of 15 volts is required to produce a full scale deflection. Now if a second coil be placed in series with this instrument and the resistance of this coil is equal to the resistance of the voltmeter, then a pressure of 30 volts will be required to produce a full scale deflection of the pointer. This second coil may be placed inside of the containing

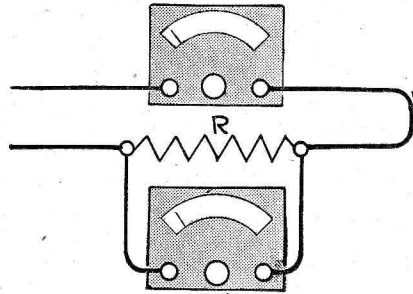

Figure 56

case of the instrument and a double marking placed on the scale, and a double set of terminals provided.

A wave meter is an instrument consisting of a variable condenser in series with a variable inductance and some means of indicating the maximum value of the current in the circuit. An instrument of this kind is used to measure the wave length of an oscillatory circuit by adjusting the inductance or capacity, or both, until the wave length is in resonance with the circuit to be measured. The resonance condition can be determined by means of the current indicating device in the meter, the current being maximum for resonance.

An ammeter is usually used to indicate the current, although in some instruments a telephone receiver and detector are used, the detector being required to make the radio frequency currents above audibility audible.

The diagram of the wave meter is shown in figure 57. In order that a wide range of wave lengths may be measured it is customary to provide several different inductances of different sizes. The condenser is of the variable type with air as a dielectric and its capacity may be varied from zero to the maximum value, which will depend upon the size, number of plates, and the distance be-

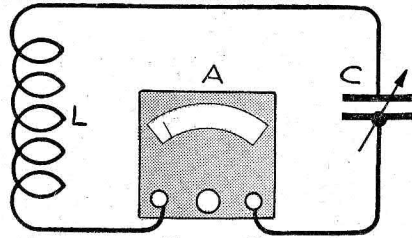

Figure 57

tween them. The condenser is provided with a dial which will give an accurate indication of the position of the variable plates of the condenser, and also its capacity. Now for each particular inductance there will be a range of wave lengths which may be measured by varying the capacity from its maximum value to its minimum value. A chart or curve usually accompanies each instrument which gives the relation between dial reading and wave length for each inductance. The inductances are most generally mounted outside the containing case of the instrument for ease in changing.

(Different types of batteries, their construction and special uses, will be taken up next by Professor Moreton. Primary cells, those which generate electrical energy by chemical action, are the subject next week.—Editor's Note.)

The Reader's View

Re Harmonica Contests

I noticed on the front page of the Radio Digest of May 2 that a harmonica contest is to be waged at Station WBAP.

The challenger, Mr. Wright, I have not met, but Mr. McBeth I met in Dallas winter before last, where the writer won first money at an adults' harmonica contest at Kieths, when my friend Borah Minevitch played. Mr. McBeth was there, but for some reason did not play.

I am glad to see this spirit of rivalry now, and hope it will be all good natured. When I was a boy we sat on the rail fence and always featured the harmonica to help out the glee (?) club.

I would like the addresses of about four or five of the best harmonica players (aside from Mr. Minevitch) and would like to have them write me in care of Radio Digest. I want only ones who have played a number of years and are able to render jazz or classics.—I. J. Lockwood.

Tune Him Out

I was glad to see the article by Robt. Whitfield of Texas regarding those pests of the air, the telegram readers. Certainly, if anyone has a just cause to complain, Mr. Whitfield has, as the chief offender is located in his state.

I agree fully with Mr. Whitfield that the main object of these laudatory gushers is to hear their names announced over the Radio. Like him, when they commence reading the telegrams my hand invariably and instantly reaches for the dials; we have that satisfaction at least.—Thomas L. Farley, Thomaston, Ga.

Finer Selectivity
Equip your receiving set with Apex Vernier Dials. They will greatly increase the efficiency of any set. Make tuning positive—bring in distant stations. Your dealer has them. If not, send \$2.00 for Royal Brass Finish—\$2.50 for Satin Silver Finish, or \$3.50 for DeLuxe Gold Plated (24k).

APEX SUPER 5
This highly efficient tuned radio frequency receiver is most advanced in design and construction. An instrument that meets every critical expectation of the radio enthusiast.

Housed in a highly finished walnut cabinet, complete with Jones Multi-plug Battery Cable. All settings highly gold plated. Sells for \$95 complete excepting accessories.

At All Good Dealers
APEX ELEC. MFG. CO.
1410 W. 59th St. Chicago
Dept. 506

ZENITH
KENNEDY
RADIODYNE
THERMIODYNE
ULTRADYNE
MURDOCK
OSZARKA
Pfanstiehl
MICHIGAN
Deresnadyne
MALONE LEMON
MASTER RADIO
ADLER-ROYAL
Howard
Pathé
HARTMAN
AUDIOLA
EAGLE
GLOBE AND
MANY OTHERS

Follow their lead
use
THORDARSON
Super
AMPLIFYING TRANSFORMERS
Standard on the majority of quality sets

Build or replace with Thordarsons. Dealers everywhere. Hook-up bulletins free. Write Thordarson Electric Mfg. Co., Chicago.

pep up your set with good tubes

SOME radio fans don't expect much "pep" from their portable sets. "Oh well, only using the small tubes," they explain. But they have quickly revised their ideas when they switched to MAGNATRON DC-199 tubes.

You'll never realize how important tubes really are until you adopt MAGNATRONS. Your dealer has them!

CONNEWEY ELECTRIC LABORATORIES
Magnatron Building Hoboken, N. J.

MAGNATRONS

The Three Curses of Radio
Power Noises, Static, Reradiating Squeals

The Kane Antennae absolutely eliminates all power noises.
The Kane Antennae cuts real "static" and reradiating squeals at least in two.
The Kane Antennae enables you to get the full benefit of your Receiving Set All Summer Long.

Another of our many satisfied customers proves our claims in the following letters.

"HE SUFFERED GRIEF AND PAIN"
Gentlemen:— Referring to your Ad in "Radio Digest" in regard to your Antennae, I have a six tube Super Zenith operating on wet "A" Batt., and am troubled with power noises and static, being located within 75 yards of a 50,000-volt power line. Located in two-story building and have set on second floor. Depot is between two railroad tracks.
Kindly advise if you think your Antennae would help me out under the above circumstances. Kindly give dimensions of Antennae, that is, length and distance from ground lowest wires would be. It is almost imperative for me to run Antennae across railroad track.
Hoping to hear from you soon,
(Signed) Yours truly, B. H. Beaver, Agent ATSF RR Co., Johannesburg, Calif.
April 14, 1925.

"THEM DAYS IS GONE FOR EVER"
Gentlemen:— I have installed one of your Antennae which you recently shipped me, and find that it has eliminated all power induction from 50,000-volt power line within 150 feet of Antennae's location.
Several stations that I could not bring in at all on account of this power induction I now bring in clearly. Needless to say it has improved greatly reception from all stations.
Thanking you for promptness in filling order and wishing you success, I am,
(Signed) Yours truly, B. H. Beaver, Agent ATSF RR Co.
Johannesburg, Calif., May 6, 1925.

See for Yourself Just What This Wonderful Antennae Is
We will sell you working drawing with instructions for erecting this wonderful Antennae for a dollar bill. If, after looking over the drawing, you decide you would rather have a factory-built Antennae than build one yourself, we will take back the drawing and allow you full purchase price on an order for an Antennae.

The Special Kane Antennae for Radiola Super-Het's..... \$ 6.50
The Regular Kane Antennae for all other sets that use a ground connection..... 13.00

Working Drawing with Instructions for Erecting, \$1.00
(Stamps Not Accepted)
Postpaid to any part of the United States or sent C.O.D. when 25% of purchase price accompanies order.

"HEAR AS YOU HAVE NEVER HEARD BEFORE"
THE KANE ANTENNAE COMPANY, Aberdeen, Wash.

Radiophone Broadcasting Stations

Corrected Every Week—Part IV

FIND MISTAKES AND YOU'LL GET DOLLAR

ONE DOLLAR will be paid to the Radio fan reader of Radio Digest submitting the most errors in any one station's listing in the Directory of Radiophone Stations, which appears in five parts, serially continuously on the next to last page. Letters must reach Radio Digest's office not later than one week from date of issue corrected. Readers are not limited to correcting one station, but such corrections must be verified by the stations themselves, and NOT by comparison to other so-called accurate Radio directories or lists. Verifications must accompany corrections. Turn in corrections for as many stations as you can find—if you can find errors! Use separate sheet of paper for each station submitted and place name and address on each sheet. In case of tie, duplicate awards will be made.

United States (Cont'd)

NOTE.—The fourth part of the schedule list appears below. Part five appears next week.

WJL, Newark, N. J. 252 meters. 50 w. Radio Shop of Newark, Inc. Announcer, W. A. Ringheim. Slogan, "The Voice of Newark." Tues, Wed, Fri, Sat, Sun, 6-8:30 pm, 8:30-12, dance music. Eastern Daylight.

WNYC, New York, N. Y. 526 meters. 1000 w. New York Municipal Radio Station. Slogan, "Municipal Broadcasting Station of the City of New York." Daily 8-5 pm, 7-30 pm, 10-30, police, 7-35, entertainment; 10-30, weather. Sun, 9-11 pm, Mark Strand theater. Eastern Daylight.

WOAC, Lima, O. 261 meters. 50 w. Page Organ Co. (H. P. Maus). Tues, Thurs, Sat, 7:30-8:30 pm. Central.

WOAI, San Antonio, Tex. 394.5 meters. 1000 w. Southern Equip. Co. (Evening News-Express). Announcer, J. Cummings. Slogan, "The Winter Playground of America. Where the Sunshine Spends the Winter." Daily ex Sun, 10:30 am, 12:15 pm, 3, markets; 7:00, sports, markets. Tues, 8:30-10:30 pm. Thurs, 9:30-10:30 pm, music. Sun, 11 am, church service; 7:45 pm, church services; 9:30-10:30, music Central.

WOAN, Lawrenceburg, Tenn. 282.8 meters. 500 w. James D. Vaughan. Announcer, James D. Vaughan. Daily and Sun, 12:15-12:45 pm, concert. Daily ex Sat, 9-10 pm, concert. Central.

WOAW, Omaha, Neb. 526 meters. 1000 w. Woodmen of the World. Announcer, "GR." Gene Rouse. Slogan, "The City Surrounded by the United States." Daily ex Sun, Wed, 12:30-2 pm; 5-7:30, 9-11. Sat, 11-12 midnight, dance. Sun, 9-10:45 am; 1:30-4 pm; 9-11. Central.

WOAX, Trenton, N. J. 240 meters. 500 w. F. J. Wolff. Slogan, "The Voice from Trenton." Daily, 12:15 pm, weather, mid-weekly crop report. Eastern daylight.

WOC, Davenport, Iowa. 483.6 meters. 2000 w. The Palmer School of Chiropractic. Announcer, Stanley W. Barnett. Slogan, "Where the West Begins and in the State Where the Tall Corn Grows." Daily ex Sun, 12:57 pm, time; 1:15, lecture, (ex Sat), closing markets, 3 (ex Sat), home hour; 5:45 pm, chimes; 6, bulletin, baseball; 6:30, (ex Tues), sandman. Wed, Fri, 4 pm, Tues, 6:30 pm, music. Wed, Sat, 9 pm, Thurs, 8 pm, Thurs, Sat, 11 pm, dance music. Mon, silent. Sun, 1 pm, orchestra. 6:50 baseball; 8 pm, service; 9:30, music. Central.

WOCL, Jamestown, N. Y. 275.2 meters. 15 w. Hotel Jamestown, Inc. Announcer, Ernest H. Kieser. Slogan, "We're on Chataqua Lake." Wed, 8 pm, Sun, 10:30 am, 7:30-9:30. Eastern.

WODA, Paterson, N. J. 202.6 meters. 10 w. James R. O'Dea. Radio & Victrola Shop.

WOI, Ames, Ia. 270 meters. 500 w. Iowa State College. Announcer, H. B. Deal. Daily ex Sun, 9:30 am, weather reports; 12:30 pm, chimes, market, weather, educational talks; 9:30, weather. Mon, 10 pm, informal program. Thurs, 8:15 pm, musical. Sun, 10:45 am, chimes. Central.

WOO, Philadelphia, Pa. 508.2 meters. 500 w. John Wanamaker. Announcer, Jos. N. Nassau. Daily ex Sun, 11 am, organ recital; weather; 11:55, time; 12-1 pm, concert; 9:15 pm, organ recital; 7:30, sports, police reports; 9:55, time; 10:02, weather. Mon, Wed, Fri, 7:30-11 pm, music, concert. Sun, 2:30 pm, Sunday school, organ; alternate am and pm services. Eastern daylight.

WOQ, Kansas City, Mo. 278 meters. 500 w. Unity School of Christianity.

WOR, Newark, N. J. 405.2 meters. 500 w. L. Bamberg & Co. Announcer, J. M. Barnett. Daily ex Sun, 7 am, 2:30-4 pm, 6:15-7:30. Mon, Wed, Sat, 8-12 midnight. Wed, 6:15-7 pm, Eastern daylight.

WORD, Batavia, Ill. 275 meters. 2000 w. Peoples Pulpit association. Announcer, B. M. Rice. Slogan, "Watchtower Station WORD." Daily ex Sun, 8:30-10 pm, Sun, 10 am, 6:45 pm. Central daylight.

WOS, Jefferson City, Mo. 440.9 meters. 500 w. Missouri State Marketing Bureau. Slogan, "Watch Our State." Daily ex Sun, first 15 min. of every hour from 9 am-2 pm, markets; 3, N. Y. stocks and markets. Daily ex Sat, Sun, 5 pm, markets. Mon, Wed, Fri, 8-10 pm, concert. Sun, 7:30-8:30 pm, church service. Tues, Fri, 5 pm, children's story hour. Central.

WOW, New Orleans, La. 270 meters. 100 w. Owl Battery company.

WPAK, Fargo, N. D. 275 meters. 100 w. N. D. Agricultural College. Announcer, Gordon Laing. Daily ex Sun, 1 pm, weather. Mon, Wed, Fri, 7:30 pm, talks. Central.

WPAZ, Charleston, W. Va. 268 meters. 20 w. West Virginia Radio Sales Corp. Tues, Fri, 7:30-8:30 pm. Eastern.

WPG, Atlantic City, N. J. 299.8 meters. 500 w. Municipality of Atlantic City. Slogan, "World's Playgrounds." Mon, Tues, Fri, 7 pm, Tues, Thurs, Fri, Sat, 9 pm; 10, classics. Mon, 8 pm, Thurs, 11 pm, Sat, 6:30 pm, concert; 10, Sun, 3:15 pm, organ; 4:15, service; 10, service. Eastern daylight.

WPSC, State College, Pa. 281 meters. 500 w. Pa. State College. Slogan, "The Voice of the Nittany Lion."

WQAA, Parkersburg, Pa. 220 meters. 500 w. Horace A. Beale, Jr. Temporarily discontinued.

WQAC, Amarillo, Tex. 234 meters. 100 w. Gish Radio Service. Irregular schedule.

WQAE, Springfield, Vt. 246 meters. 50 w. Moore Radio News Station. Announcer, Ernest S. Newell. Slogan, "Among the Green Hills of Vermont." Sat, 11-1 am, Sun, 10:30 am, church service; 7 pm, service. Eastern.

WQAM, Miami, Fla. 268 meters. 100 w. Electrical Equip. Co. Announcer, Frederick W. Mizer. Slogan, "It's Always True in Miami." The Most Southern Radiocasting Station in U. S. Tues, Thurs, Sat, 10-12 midnight, music. Sun, 7:30-9 pm, Eastern.

WQAN, Scranton, Pa. 250 meters. 100 w. Scranton Times. Announcer, T. V. Nealon. Slogan, "The Voice of the Anthracite." Daily ex Sun, 12:30-1 pm, 4:15-4:45, news, reports, music. Tues, Fri, 8 pm, entertainment. Eastern.

WQAO, New York City, N. Y. 360 meters. 100 w.

Calvary Baptist Church. Announcer, R. E. Bogardus. Slogan, "The First Church Owned and Operated Broadcasting Station in the World." Sun, 11:30 am, 7-30 pm, church services. Eastern daylight.

WQAS, Lowell, Mass. 252 meters. 100 w. Walter Co.

WQJ, Chicago, Ill. 447.5 meters. 500 w. Calumet Baking Powder Company—Rainbow Gardens. Announcer, Jerry Sullivan. Daily ex Sun, 11-12 m, 3-4 pm, woman's hour. Daily ex Sun, Mon, 7-8 pm, 10-1, 1-2, Ginger hour. Sat, 10-3 am, Sun, 10:30 am, church service; 3-4 pm; 8-12 pm, music. Central daylight.

WRAA, Houston, Tex. 256 meters. 100 w. The Rice Institute.

WRAF, La Porte, Ind. 224 meters. 100 w. Radio Club, Inc. Announcer, Charles Middleton. Slogan, "The Voice of the Maple City." Mon, Thurs, Sun, 8-30 pm. Central.

WRAK, Escanaba, Mich. 256 meters. 100 w. Economy Light Company. Announcer, Ken Voght. Slogan, "The Gateway to Cloverland." Mon, Fri, 8:30 pm. Eastern.

WRAL, St. Croix Falls, Wis. 248 meters. 100 w. Northern States Power Co. Announcer, D. H. Hiebert. Slogan, "On the Delis of the St. Croix."

WRAM, Galveston, Ill. 244 meters. 100 w. Lombard College. Mon, 9:30-11 pm, Fri, 8-9:30 pm. Central.

WRAY, Yellow Springs, O. 263 meters. 100 w. Antioch College. Announcer, Charles Hoffman. Wed, 8 pm, music; 9, educational. Sun, 7 pm. Central.

WRAW, Reading, Pa. 238 meters. 100 w. Avenue Radio & Elec Shop. Slogan, "The Schuylkill Valley Echo." Announcer, C. M. Chafey. Thurs, 10-11:30 pm. Eastern.

WRAX, Gloucester City, N. J. 268 meters. 500 w. Flexon's Garage. Announcer, Anna D. Flexon. Mon, Thurs, Fri, evenings, program. Eastern.

WRBC, Valparaiso, Ind. 278 meters. 500 w. Immanuel Lutheran church. Announcer, Forrest Jones. Slogan, "World Redeemed by Christ." Mon, 7:30 pm, Sun, 7:30, church service. Eastern.

WRC, Washington, D. C. 468.5 meters. 1000 w. Radio Corp'n of America. Announcer, George F. Ross. Slogan, "The Voice of the Capitol." Mon, Wed, Fri, 1-6:30 pm, Tues, Thurs, Sat, 1-12 midnight. Eastern.

WREO, Lansing, Mich. 285.5 meters. 500 w. Leo Watch Rec. Daily ex Sun, 10 pm, weather. Tues, Thurs, 8:15 pm, music. Fri, 1-3 am, coast program; 8 pm, 10:30, Sat, 10-12 midnight, orchestra. Sun, 10 am, 7 pm, services. Eastern.

WRHF, Washington, D. C. 256 meters. 50 w. Washington Radio Hospital. Daily ex Sun, 2:30 pm. Eastern.

WRK, Hamilton, O. 270 meters. 200 w. Doron Bros. Elec. Co. Slogan, "The Oldest Station in Existence." Fri, 8:15 pm, music, lecture. Sun, 10:15 am, 7:30 pm, church services. Central.

WRM, Urbana, Ill. 273 meters. 500 w. Univ. of Ill. Irregular schedule. Broadcasts sports.

WRR, Dallas, Tex. 272.6 meters. 350 w. City of Dallas. Announcer, C. H. Garrett. Daily ex Sun, 11:30-12:30 pm, weather, music; 2:45-3:30, sports, markets, news; 7:30, police bulletins; 7:30-8:30 pm, music. Tues, 8:30-9:30 am, Sat, 12-2 am, organ. Sun, 10 am, church service. Central.

WRW, Tarrytown, N. Y. 272.6 meters. 500 w. Tarrytown Radio Research Laboratory. Announcer, Frederick Koenig. Slogan, "Everything in Radio." Daily ex Sun, Wed, 9-11:30 pm, Mon, 7-8 pm, Wed, 10-11:30 pm, Sun, 8-9 pm, 10:30-11:30. Eastern daylight.

WSAB, Cape Girardeau, Mo. 275 meters. 100 w. Southeast Mo. State Teachers College. Mon, Wed, 3:30 pm, lecture; 9, concert. Central.

WSAC, Clemson College, S. C. 336.9 meters. 500 w. Clemson Agri. College. Announcer, H. E. Gaffney. Wed, 8 pm. Eastern.

WSAD, Providence, R. I. 256 meters. 100 w. Posters' Jewlers.

WSAG, St. Petersburg, Fla. 266 meters. 500 w. Gospel tabernacle.

WSAI, Mason, O. 325.9 meters. 5000 w. United States Playing Card Co. Announcer, P. A. Greene. Mon, 10-12 m, Tues, 7-10 pm, Wed, 10-12 midnight, Thurs, 8-10 pm, Sat, 8-10; 12-1:45 am, Sun, 3-4 pm, 8-11. Central daylight.

WSAJ, Grove City, Pa. 220 meters. 250 w. Grove City College. Announcer, Wm. L. Harmon. College activities. Wed, 7:30-9 pm, music, irregular programs. Eastern.

WSAN, Allentown, Pa. 229 meters. 50 w. Allentown Call Pub. Co. Announcer, C. Fred Ritter. Tues, Thurs, 8-9 pm. Eastern.

WSAP, New York, N. Y. 263 meters. 250 w. City Temple. Thurs, 8-9:30 pm, Sat, 10:45-12 m, Sun, 7:30-9:30 pm. Eastern daylight.

WSAR, Fall River, Mass. 254 meters. 100 w. Doughty & Welch Elec. Co., Inc. Announcer, Charles McCarthy. Daily ex Sun, 12-1 pm, Wed, 7-8:30 pm, Sun, 10:30-12 m, 4:30-6 pm. Eastern.

WSAU, Chesham, N. H. 229 meters. 10 w. Camp Marienfeld.

WSAX, Chicago, Ill. 268 meters. 250 w. Chicago Radio Lab.

WSAZ, Pomeroy, Ohio. 244 meters. 50 w. Chase Elec. Shop. Announcer, Glenn E. Chase. Wed, 9:30 pm, music. Sun, 10:30 am, 2:30 pm. Eastern.

WSB, Atlanta, Ga. 428.3 meters. 500 w. Atlanta Journal. Announcer, Lambdin Kay. Slogan, "The Voice of the South." Daily ex Sun, 12-1 pm, music, weather; 2:30, reports; 5, orchestra, time story; 8-9, concert (ex Wed) 10:45-12, concert. Sun, 5-6, 7:30-9:15, church services. Central.

WSKC, Bay City, Mich. 261 meters. 50 w. World's Star Knitting Co.

WSL, Utica, N. Y. 242 meters. 100 w. J. & M. Elec. Co. Daily ex Sat, Sun, 11-11:30 am, 5-6 pm, music, news. Mon, Wed, Sat, 8-9 pm, Sun, 10:30-12 m, 7:30-9 pm. Church services. Eastern.

WSMB, New Orleans, La. 319 meters. 500 w. Saenger Amusement Co. and The Madison Blanche Co. Daily ex Sun, 12:30-1:30 pm, 6:30-7:30. Mon, Wed, Thurs, Sat, 8:30-10:30 pm. Central.

WSMH, Owosso, Mich. 240 meters. 10 w. Shattuck Music House.

WSMK, Dayton, Ohio. 275 meters. 150 w. S. M. K. Radio Corp. Announcer, S. M. Krohn, Jr. Slogan, "Watch Dayton's Broadcasting Station." Tues, Thurs, Sat, 8-10 pm, Sat, 11:45-12:30 am, dance music. Central.

WSOE, Milwaukee, Wis. 246 meters. 100 w. School of Engineering of Milwaukee. Announcer, O. W. Meissner. Slogan, "In the Land of the Sky-blue Waters." Daily ex Sat, Sun, 9-10 am, lecture; 1-3 pm, talk; 5-6:30, concert; 6-8:30, market. Mon, Fri, 9-12 mid, music. Tues, Thurs, Sat, 7:30-9 pm, music. Sun, 9:30 am, service; 10:30-11:30; 1-3 pm; 7:30-8:30, services. Central.

WSRF, Broadlands, Ill. 233 meters. 10 w. Dick's and Harden Radio Station. Announcer, "Red" Harden.

WSRO, Hamilton, Ohio. 252 meters. 100 w. Radio Co. Announcer, Harry W. Fahlander. Tues, Fri, 8-10 pm, orchestra. Sun, 2-4 pm, orchestra. Central.

WSUI, Iowa City, Ia. 483.6 meters. 500 w. Univ. of Iowa. Announcer, Carl Menzer. Mon, Tues, Wed, Thurs, Fri, 12:30-1 pm, Wed, 9-9:30 am, Mon, Wed, 7:30 pm, course; 7:45, lecture; 8, lecture. Sun, 7 pm, children's hour; 9-9:30, music. Central.

WSV, Auburn, Ala. 250 meters. 500 w. Alabama Polytechnic Institute.

WTAB, Fall River, Mass. 266 meters. 100 w. Fall River Daily Herald. Daily and Sun, 6 pm, organ. Tues, Thurs, 8-10 pm, Wed, Sat, 5 pm. Eastern standard.

WTAC, Johnstown, Pa. 267.8 meters. 100 w. Penn. Tractor Co. Announcer, D. B. Cole. Mon, Fri, 7:30-10 pm. Eastern.

WTAL, Toledo, Ohio. 252 meters. 10 w. Toledo Radio & Elec. Co. Announcer, E. R. Frank. Slogan, "The Gateway to the Sea." Daily ex Sun, 8:30 pm. Eastern.

WTAM, Cleveland, Ohio. 389.4 meters. 1,500 w. Willard Storage Battery Co. Announcer, A. B. Harste. Slogan, "The Voice from the Storage Battery." Daily ex Sun, 6-7 pm, dinner program. Mon, 8-12 pm, concert. Wed, 8-1 am. Sat, 9-12 midnight, dance. Eastern.

WTAP, Cambridge, Ill. 242 meters. 100 w. Cambridge Radio & Elec. Co. Announcer, A. McIntosh.

WTAQ, Osseo, Wis. 254 meters. 200 w. S. H. Van Gorden & Son. Announcer, Mrs. C. S. Van Gorden. Slogan, "The Voice of the Wilderness." Daily ex Sun, 10:30 am, 12:15 pm, 6:15, weather, markets; 6:30, code. Fri, Sun, 7:30 pm. Central.

WTAR, Norfolk, Va. 261 meters. 100 w. Reliance Electric Co. Announcer, J. K. Bohannon. Slogan, "Down in Old Virginia." Daily ex Sun, 5:55 pm, weather, tide reports. Tues, 7:30 pm, weekly review; 8-9, musical program. Eastern.

WTAS, Elgin, Ill. 302.8 meters. 1,000 w. Charles E. Erbstein. Slogan, "Willie, Tommie, Annie and Sammie." Daily ex Sun, Thurs, 8-11 pm, Thurs, Sun, 7-12, music. Central daylight.

WTAT, Boston, Mass. 244 meters. 100 w. Edison Elec. Illuminating Co. (portable). Announcer, Leon B. Hentz.

WTAU, Tecumseh, Neb. 242 meters. 10 w. Ruezg Battery & Elec. Co. Tues, 8:30 pm. Central.

WTAW, College Station, Tex. 270 meters. 250 w. Agricultural and Mechanical College of Texas. Silent during the summer.

WTAX, Streator, Ill. 231 meters. 50 w. Williams Hardware Co. Radio Division. Announcer, N. B. Williams. Slogan, "Tappa Kegga Nails." Mon, 6:30-8 pm. Central.

WTAZ, Lambertville, N. J. 261 meters. 15 w. Thomas J. McHugh. 352.7 meters. 500 w. Eastern.

WTG, Manhattan, Kan. 273 meters. 50 w. Kan. State Agri. College. Daily, 9:55 am, 4 pm, weather. Central.

WTHS, Flint, Mich. 218.8 meters. 250 w. Flint Senior H. S.

WTIC, Hartford, Conn. 348.6 meters. 500 w. The Travelers Insurance Company. Slogan, "The Insurance City." Mon, 3:45-7:30 pm; Tues, Fri, 7-10:30; Wed, 5:45-6 pm; Thurs, 5:45-7:30. Eastern.

WWAD, Philadelphia, Pa. 250 meters. 100 w. Wright & Wright, Inc. Announcer, H. W. Feyhl. Slogan, "Penn City Station." Mon, 7:45 pm, Thurs, 7:45 pm. Eastern daylight.

WWAE, Plainfield, Ill. 242 meters. 500 w. Lawrence G. Eaton. Announcer, James J. Whalen.

WWAO, Houghton, Mich. 263 meters. 250 w. Michigan College of Mines. Announcer, M. G. Sateren. Daily ex Sun, 12-12:45 pm, music, news, weather, markets. Tues, Thurs, 8-10 pm, concert. Central.

WWI, Dearborn, Mich. 266 meters. 500 w. Ford Motor Co. Wed, 8-10 pm, music, lectures. Eastern.

WWJ, Detroit, Mich. 352.7 meters. 500 w. The Detroit News. Announcer, W. L. Tyson. Daily ex Sun, 8-8:30 am, setting-up exercises; 9:30-9:45, household hints; 10:25-10:30, weather; 11:55-12, time; 12:05-12:45 pm, music; 3-3:55, music; 3:55, 4-6, baseball scores, markets. Daily ex Sat, Sun, 6-7, dinner concert; 8, music. Mon, Wed, Fri, 9 pm, orchestra. Wed, 10 pm, orchestra. Sun, 11 am, church service; 2-3 pm, concert; 6:20, Roxy and his Gang. Eastern.

WWL, New Orleans, La. 275 meters. 100 w. Loyola Univ. Announcer, O. L. Abell. Sat, 8-9 pm. Central.

Argentina

B-I, Buenos Aires, Argentina. Francisco J. Brusa.

LOR, Buenos Aires, Argentina. 350-410 meters. 500 w. Cia Radio Argentina.

LOV, Buenos Aires, Argentina. 350 meters. 1,000 w. Francisco J. Brusa.

LOW, Buenos Aires, Argentina. 325 meters. 500 w. Splendid Theater. Announcer, Luis Diaz.

LOX, Buenos Aires, Argentina. 375 meters. Radio Cultura.

LOY, Buenos Aires, Argentina. Radio Nacional. Announcer, Osvaldo P. Valla.

TCR, Buenos Aires, Argentina. 325-300 meters. 100 w. Francisco J. Brusa.

Australia

2BL, Sydney, Australia. 350 meters. 5,000 w. Broadcasters Limited.

2FC, Sydney, Australia. 1,100 meters. 5,000 w. Farmer & Co., Ltd.

3AR, Melbourne, Australia. 480 meters. 1,600 w. Associated Radio Co., Ltd.

5CL, Adelaide, South Australia. 375 meters. 5,000 w. Central Broadcasters, Ltd.

6WF, Perth, Australia. 1,250 meters. 5,000 w. West Australian Farmers, Ltd.

Austria

Graz, Austria. 404 meters. Ravag.

Vienna, Austria. 530 meters. Ravag.

Brazil

SPE, Rio de Janeiro, Brazil. 250 meters. 500 w. Dept. of National Telegraphs.

Bahia, Brazil. Radio Sociedade do Bahia.

Belle Horizantes, Brazil. 500 w. National Telegraph Service.

Rio de Janeiro, Brazil. 6,000 w. Marconi (Radio Sociedade do Rio de Janeiro).

Sao Paulo, Brazil. 10,000 w. Radio Bandeirantes.

Belgium

BAV, Haeren, Belgium. 800 meters. 1,000 w. Daily, 1 pm, 2, 4:50, 6:50, weather.

SRB, Brussels, Belgium. 265 meters. 1,500 w.

British West Indies

Curacao, British West Indies. Department of Finance.

Canada

(The power ratings of the following Canadian stations are given in "oscillating" watts, rather than watts output—the method in which American stations are rated in this directory.)

CFAC, Calgary, Alta. Can. 434.5 meters. 500 w. Calgary Herald. Announcer, Fred Carleton. Daily ex Sun, 1 pm, news, markets, music. Daily ex Sat, Sun, 3:30-4:30 pm, music. Tues, 7:45-8:45 pm songs. Thurs, 9-11 pm, music. (CNRT). Friday, 7-8 pm, organ; 11-12, test. Mountain.

CFCA, Toronto, Ont. Can. 356.9 meters. 500 w. Toronto Star. Announcer, E. J. Bowers. Daily ex Sun, 12 m. weather, news, stocks; 5:30-6 pm, news, bedtime story. Daily ex Sun, Fri, 8-9 pm, Thurs, 10-11:30 pm, popular program. Fri, 8-9 pm, (CNRT) W. W. Grant, Ltd. Slogan, "Voice of the Prairies." Tues, 11:30 pm, Bronco Busters; Wed, 9, 7-8 pm, Sat, 10 pm, Sun, (alternate) 11 am, 7:30 pm, service. Mountain.

CFCR, Sudbury, Ont. Can. 410 meters. 200 w. Laurentide Air Service, Ltd. Off the air.

CFCT, Victoria, B. C., Can. 329.5 meters. 250 w. Henry Birks & Sons, Ltd. Slogan, "Follow the Birds to Victoria." "Canada's First." Tues, Thurs, 7-8 pm, music. Wed, Fri, 8-9:30 pm, concert. Sun, 11 am, 7:30 pm, church services. Pacific.

CFCU, Hamilton, Ont., Can. 340.7 meters. 5 w. Jack V. Elliot, Ltd.

CFHG, Calgary, Alta., Can. 434.5 meters. 750 w. Henry Birks & Sons, Ltd.

CFKC, Thorold, Ont., Can. 248 meters. 75 w. Thorold Radio Supply. Daily ex Sun, 12-12:30 pm; 5-6. Tues, Thurs, Sat, 8:30-10:30 pm, Sun, 11 am, church service; 2-4 pm, 8 pm, sacred concert, music.

CFQC, Saskatoon, Sask., Can. 329.5 meters. 250 w. The Electric Shop, Ltd. Announcer, D. F. Streb.

Slogan, "The Hub City of the West Where No. 1 Northern Hard Wheat Grows." Daily ex Sun, 12:15-2 pm, markets, reports, music. Tues, 9-11 pm. Thurs, 7:45-9 pm, address, music. Fri, 9-11:30 pm, dance program. Sun, 11 am, church service. Mountain.

CFRC, Kingston, Ont., Can. 450 meters. 500 w. Queen's University. Discontinued temporarily.

CFXC, New Westminster, B. C. 291.1 meters. 20 w. Westminster Trust Co. and Hunter & Rumble, Ltd. Announcer, F. Sterling. Slogan, "Voice of the Fraser River." Mon, Wed, Fri, 7:30-8:30 pm. Pacific.

CFYC, Vancouver, B. C. 410.7 meters. 100 w. Commercial Radio, Ltd. Slogan, "Canada's Flourishing Young City."

CHBC, Calgary, Alta., Can. 434.5 meters. 750 w. The Calgary Albertan. Daily ex Sun, Sat, 6-6:30 pm, news, stock quotations, music. Mountain.

CHCM, Calgary, Alta., Can. 434.5 meters. 750 w. Riley & McCormick, Ltd. Slogan, "Western Canada's Leading Leather Goods Store." Thurs, 8-9 pm. Mountain.

CHCS, Hamilton, Ont., Can. 340.7 meters. 100 w. Hamilton Spigot. Announcer, H. Barnshaw. Daily ex Sun, 6:45 pm, news, markets, baseball. Sat, 10-12 midnight, dance. Sun, 11 am, 7 pm, Eastern.

CHIC, Toronto, Can. 356.9 meters. 500 w. Northern Electric Company. Announcer, Rudolph Weese. Alternate Thurs, 9-11:30 pm. Alternate Mon, 10-11:30 pm. Last Sat in month, 9-11:30. Eastern.

CHNC, Toronto, Can. 356.9 meters. 500 w. Toronto Radio Research society. Announcer, E. H. Comb. Mon, 8:30 pm, concert. Programs CHIC CKNC through this station. Eastern daylight.

CHUC, Saskatoon, Sask., Can. 329.5 meters. 250 w. International Bible Students' association. Announcer, E. G. Esson. Mon, Wed, 8-10 pm, Sun, 1-2 pm, 7:30-9.

CHXC, Ottawa, Ont., Can. 434.5 meters. 250 w. J. E. Booth, Jr.

CHYC, Montreal, Que., Can. 410.96 meters. 500 w. Northern Elec. Co. Announcer, N. S. Richards. Wed, 8:30 pm, Sun, 7 pm. CNRM programs occasionally. Eastern daylight.

CJCA, Edmonton, Alta., Can. 516.9 meters. 500 w. Edmonton Journal. Announcer, A. Rice. Slogan, "The Sunbelt of Alberta." Tues, 4-6 pm, 10-12 midnight, dance. Sun, 11 am, 7 pm, Eastern.

CHIC, Toronto, Can. 356.9 meters. 500 w. Northern Electric Company. Announcer, Rudolph Weese. Alternate Thurs, 9-11:30 pm. Alternate Mon, 10-11:30 pm. Last Sat in month, 9-11:30. Eastern.

CHNC, Toronto, Can. 356.9 meters. 500 w. Toronto Radio Research society. Announcer, E. H. Comb. Mon, 8:30 pm, concert. Programs CHIC CKNC through this station. Eastern daylight.

CHUC, Saskatoon, Sask., Can. 329.5 meters. 250 w. International Bible Students' association. Announcer, E. G. Esson. Mon, Wed, 8-10 pm, Sun, 1-2 pm, 7:30-9.

CHXC, Ottawa, Ont., Can. 434.5 meters. 250 w. J. E. Booth, Jr.

CHYC, Montreal, Que., Can. 410.96 meters. 500 w. Northern Elec. Co. Announcer, N. S. Richards. Wed, 8:30 pm, Sun, 7 pm. CNRM programs occasionally. Eastern daylight.

CJCL, Montreal, Can. 270 meters. 10 w. A. Couture.

CJCM, Mont Joli, P. Q., Can. 312.3 meters. 2,500 w. Dr. J. L. P. Landry (Chief Announcer). Slogan: "Three weeks below Quebec on the top of the world." Daily ex Sun, 1 am, Mon, Wed, Sun, 5-6 pm; 8:30-12. Eastern.

CJGC, London, Ont., Can. 329.5 meters. 50 w. London Free Press. Daily ex Sun, 1-2 pm, news, stocks, music. Tues, Thurs, Fri, 7:15-8:40 pm. Fri, 11-12 midnight. Eastern.

CKAC, Montreal, Que., Can. 410.7 meters. 1,500 w. La Presse. Announcer, Jacques Cartier. Mon, Wed, Fri, Mon, 1:45 pm, orchestra. Daily ex Sat, 7 pm, weather, markets, stocks. Tues, Thurs, Sat, 7 pm, children's hour; 7:30, concert; 8:30 pm, studio concert; 10:30, dance. Sun, 4:30 pm, sacred concert. Midnight follies first and third Wednesdays of month. CNRM programs occasionally. Eastern daylight.

CKCD, Vancouver, B. C., Can. 397 meters. 500 w. Vancouver Daily Province. Announcer, William Rose. Slogan, "Canada's Western Gateway." Daily ex Sun, 8:30-9:30 pm, music, news, entertainment. Pacific.

CKKC, Regina, Sask., Can. 356 meters. 1,000 w. Leader Pub. Co. Announcer, A. W. Hooper. "The Queen City of the West." Daily ex Sat, Sun, Tues, 9:45-10:30 am; 1-2 pm; 7:30-8:15, music, news, markets. Tues, 9:45-10:30 am; 1-2 pm; 8-10. Sat, 9:45-10:30 am; 1-2 pm. Sun, 9-10 pm, church services. Mountain.

CKGO, Ottawa, Ont., Can. 434.5 meters. 100 w. Dr. G. M. Geldert (Ottawa Radio Assn.) Announcer, Dr. O. K. Gibson. Slogan, "Ottawa's Radio Voice." "The Community Voice of Canada's Capital." Tues, 8-10 pm, Sun, 7 pm, services; 9, sacred concert. Eastern.

CKCX, Calgary, Alta., Can. 434.5 meters. 750 w. P. Burns & Co., Ltd. Tues, 9-10 pm, music, lectures. Mountain.

CKFC, Vancouver, B. C., Can. 410.7 meters. 50 w. First Congregational church.

CKLK, Calgary, Alta., Can. 434.5 meters. 50 w. Wilkinson Electric Co., Ltd.

CKNC, Toronto, Ont., Can. 356.9 meters. 500 w. Canadian National Carbon Co., Ltd.

CKQC, Hamilton, Ont., Can. 340.7 meters. 50 w. Western Radio Supply Co., Ltd. Announcer, H. W. Slack. Slogan, "In the Garden of Canada." Mon, Wed, Fri, 8-9 pm, music entertainment. Sun, 7-8 pm, church services. Eastern.

CKY, Winnipeg, Man., Can. 384.4 meters. 500 w. Manitoba Tel. System. Announcer, D. R. P. Coats. Slogan, "Manitoba's Own Station." Daily ex Sun, 12:30-1:30 pm, music, lectures, markets, weather, etc.; 4-5, concert; Tues, Fri, 8:30 pm, lecture; 8:45-10:30, concert. Thurs, 8, Canadian Nat. Railways concert (CNRW). Announcer R. H. Roberts. Sun, 7 pm, church services. Central.

CNRA, Moncton, N. B., Can. 312.3 meters. 500 w. Canadian National Railways. Slogan, "Maritime Radio Station." Tues, Fri, 8:30 pm, bedtime stories; 8, markets; 8:30-11:30, music. Atlantic.

CNRC, Calgary, Alta., Can. 434.5 meters. 750 w. Canadian National Railways. Wed, 9 pm. Mountain.

CNRE, Edmonton, Alta., Can. 516.9 meters. 500 w. Canadian National Railways. Fri, 7:30-8 pm, 8:30-10:30. Mountain.

CNRM, Montreal, Que., Can. 410.7 meters. 500-1,500 w. Canadian National Railways. Wed, 8:30 pm. Eastern daylight.

CNRO, Ottawa, Can. 434.5 meters. 500 w. Canadian National Railways. Announcer, A. W. Hooper. Wed, Sat, 7:30 pm, markets, bedtime story; 8, 10:30, dance program. Eastern.

CNRR, Regina, Sask., Can. 312.3 meters.

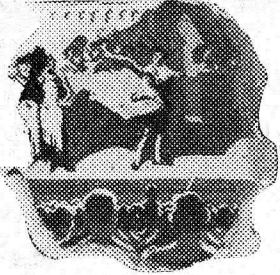

Music Master
Resonant Wood
Insures
Natural
Tone
Quality

The Triumph of the Toreador and of MUSIC MASTER!

THE thrill and tingle, the fling and flare of the famous Toreador Song from *Carmen*, poured out in all the flawless perfection of grand opera by the recreative magic of Music Master. The singer himself—almost—stands there beside your Music Master, singing for you!

Music Master's recreative powers are a combination of science and art

- transmitting instrument of scientific precision in the base.
- scientifically designed tone chamber of heavy cast aluminum that develops sound without distortion.
- and Music Master's surpassing distinction, amplifying bell of resonant mahogany as scientifically accurate, yet artistically perfect, as the sounding board of a concert grand piano.

The Musical Instrument of Radio There IS No Substitute

Ask any radio dealer to demonstrate these statements of fact in your own home—on your own radio set.

And as to "guarantee," remember: Music Master products are guaranteed without condition, without reservation, by the dealer, and back of him, the Music Master Corporation.

Music Master Corporation

Makers and Distributors of High-Grade Radio Apparatus
10th and Cherry Streets
Chicago PHILADELPHIA Pittsburgh
Canadian Factory: Kitchener, Ontario

Model V, Metal Cabinet, Mahogany Finish, Wood \$ 18
Bell 18

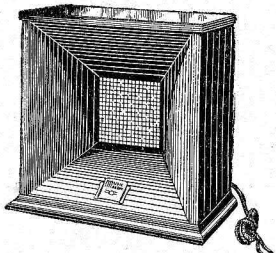

Model VIII, Mahogany Cabinet with "full-floating" Wood \$ 35
Bell 35

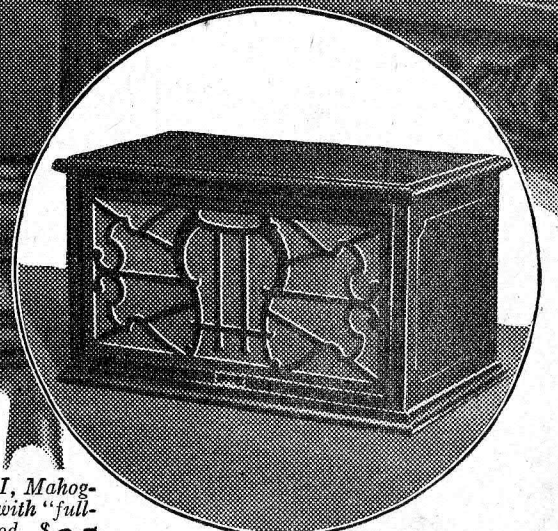

(Prices of all models slightly higher in Canada)

MUSIC MASTER RADIO REPRODUCER