

Drilling and Assembly Layouts for "Traveler"; How to Put up Aerial Masts; Last Minute Play-by-Play Football Schedules; WJR, at Detroit, in Pictures

Radio Digest

EVERY
WEEK

PROGRAMS
Illustrated

TEN
CENTS

REG. U. S. PAT. OFF. & DOM. OF CANADA

Vol. XV

Copyright 1925
By Radio Digest Publishing Co.

SATURDAY, OCTOBER 17, 1925

No. 2

ERECT POWERFUL AERIAL

MANY SILENT NIGHT REASONS ARE GIVEN

WRITER POINTS OUT NEEDS FOR PERIODS OF REST

Stations Would Benefit Along with Fans If Suggested Plans are Followed, Is View

Editor's Note.—The following manuscript, "Why the Silent Night," by Pierson W. Banning, was submitted prior to the practical settlement of the Chicago silent night question, when all Chicago area stations, with the exception of WOK, the Neutrowound Radio company's station, agreed to keep silent every Monday night. However, the argument here presented is worth consideration in other localities, such as New York city, where congestion demands a silent night.

By Pierson W. Banning

ENTIRELY different reasons are given here for the need of a silent night on the air.

So many stations means too strenuous competition among stations, requiring placing of the same artists and talent on the air, altogether too often for their own good, and the fullest enjoyment of the listening public.

This tension causes program managers to grow stale. This likewise applies to announcers and the technical staff, who become mechanical, losing their finer qualities of execution. Under these conditions no station can continue indefinitely to maintain the constantly increasing tension and interest, the majority of patrons require, to continue to hold their interest.

It means that the concerns financing
(Continued on page 2)



RUGBY MASTS WILL RISE UP 820 FEET HIGH

Towers Weigh 300 Tons

Trials of British Transatlantic Commercial Telephone Station to Begin in November

LONDON.—In the new year Britain will be able to talk to the world without any intermediaries. The Radio station at Rugby is then scheduled to open. Meanwhile trials start in November.

Everything at Rugby station has been planned on a gigantic scale. The aerial masts weigh 300 tons each, and are the tallest in the British empire—820 feet high, nearly as high as the Woolworth building.

Never before has the height of the Eiffel tower aerial been so nearly approached, and although that is 900 feet the tower's aerial lines run from the summit to the ground, and do not maintain the high level of the Rugby aerial throughout their length.

The Rugby aerial will be one and one-half miles long and one-half mile wide, and the twelve giant masts, of which the tops are often veiled with clouds, span the countryside. Within the next year Britain will be in the front rank among the European powers in the matter of world-wide Radio communications. Every continent will be conducted up to
(Continued on page 2)



Radio becomes more interesting to the men every day. Especially is this true when they hear voices of stars they know are as pretty as the three pictured here. In the center is Tillie Urkov, a contralto on the regular WTAS, Elgin, staff. To the left is Ina Mitchell Butler, Hollywood queen, a regular at KFNB, the motion picture broadcaster of Warner Brothers. Vera Meyers, right, is leading lady in the Proctor Players and she has pleased many with musical comedy offerings from WHAZ, Rensselaer Polytechnic Institute at Troy, N. Y.



RADIO OPERA STARS PROGRAM APPROVED

GOVERNMENT HEADS VOICE VIEWS ON KENT TIE-UP

Hoover Believes Future of Broadcasting Depends on Improvement of Programs in This Manner

WASHINGTON.—Gratification over the announcement by A. Atwater Kent, Radio manufacturer of Philadelphia, that the world's leading grand opera soloists and concert artists will be heard over the Radio in a series of Sunday evening concerts this winter, is expressed by government officials who are fostering the development of Radio broadcasting.

The concerts are strongly in accord with Secretary Hoover's appeal for better Radio programs, it was said at the department of commerce here.

The department has given much thought to the improvement of programs that go out on the air. Secretary Hoover is said to feel that in view of the millions of individuals it reaches, Radio should not be regarded simply as a luxury and something to play with, but that it should render a distinct public service in the character of programs it carried into the home, and that the influence should be uplifting. Expressions of approval are heard in many quarters that influence different phases of our national life.

Dr. John J. Tigert, United States commissioner of education, expressed the belief that the bringing of the best class of music into homes, which the series will do, would be of great educational value to Radio audiences.

Dr. J. C. Gilbert, of the bureau of agricultural economics, of the department of agriculture in Washington, said he thought the new program would probably mean more to the farmer than to the city man. Through the county agents of the department of agriculture, Dr. Gilbert has made a survey of Radio on the farm, and he knows the farmer's attitude.

SILENT NIGHT REASONS

(Continued from page 1)

these programs all too frequently do not hold their audiences in a way they would wish. This is evident from the way various large concerns have discontinued to broadcast. This indicates there is a growing feeling that there is far less pulling power to many programs using the same talent so often, when used as an advertising medium. This applies to practically every large broadcast station in the country.

A continuance of this means the loss by discontinuance of many fans these stations originally counted on to such an extent, especially from among the classes who have money to spend with their advertisers.

Psychologically the whole thing is in favor of the stations, if they will now cease in surfeiting their audiences, and instead withhold from them regularly each week one entire night's entertainment. What is good for the audience is good for the stations as well.

And again, it permits DX hounds an opportunity to reach out for programs elsewhere. The psychology of this again works in favor of the local stations, for by allowing these DX hunters the opportunity they seek, it will make them stronger boosters for the local stations which they receive with so much better quality than elsewhere. This tends to add these distance seekers to the list of local prospects as potential customers for the concerns presenting local programs.

Bedridden Are Considered

For those who are bedridden, one silent night a week, while it will be missed, will not prove fatal especially as the stations can bend their efforts towards giving each of you that much better programs the remainder of the week. This will be your contribution towards helping obtain the best possible programs for everyone.

Each Radio district by agreement might divide its stations into two classes; those above a certain halfway wave length and those below that halfway wave length. The stations above the dividing wave length would, on the silent night, remain off the air from 6:30 to 9:30 o'clock one week. Those below the dividing wave length, would remain off the air the same hours of the same night the next week. This would permit distance hunters a brief time to reach out, yet permit programs by half the stations just the same. This would be a makeshift and to use only to try out the other suggestions offered.

Local stations have nothing to lose but everything to gain by adopting a uniform silent night. Stations—don't kill the interest of your audience by overdoing your artists and talent. By killing the interest of your broadcasting audience in your programs you lessen your broadcasting value as an advertising medium for

WHEN OPERA RECOGNIZED RADIO



A historical scene in the annals of Radio is portrayed by the above picture, in which noted opera stars are seen signing contracts to broadcast on the Sunday night Atwater Kent programs from WEA and linked stations. Twenty-five of the world's best singers and musicians have thus been made available to the listening audience through the philanthropy of A. Atwater Kent. Left to right, the photo shows Anna Case (signing), Mme. Louise Homer, Renauld Werenrath, A. Atwater Kent, Tosca Seidel and Hilda Lashenska, all of whom, among others, are signing the contracts with Mr. Kent.

your patrons. That automatically works against your securing the continued support of your present business houses and others.

Your aim should be to try to whet, not dull the appetite, and interest for your programs. Already the interest is rapidly dulling among many you cannot afford to lose from a financial standpoint. Self-preservation should dictate what your first interest should be in this matter.

S.S. Malolo Boats Have Radio

PHILADELPHIA.—The S.S. Malolo, which is to be the largest and fastest large passenger steamship ever built in the United States, will carry as part of her lifeboat equipment two 30-foot steel motorboats fitted out with the most up-to-date Radio transmitting and receiving sets. The apparatus will consist of a 500-watt transmitting set and a sensitive long distance receiver.

CONTENTS

Radio Digest, Illustrated, Volume XV, Number 2, published Chicago, Illinois, October 17, 1925. Published weekly by Radio Digest Publishing Company, 510 N. Dearborn Street, Chicago, Illinois. Subscription rates, yearly, Five Dollars; Foreign Postage One Dollar additional; single copies Ten Cents. Entered as second class matter at the post office at Chicago, Illinois, under the Act of March 3, 1879.

All the Live News of Radio.....	1 to 7
Station WJR, Detroit, "Where Joy Reigns".....	5
Advance Programs for the Week.....	8 to 14
An Evening at Home with the Listener In, a chart in central time, showing when to listen in for your favorite stations.....	14
Following Sports Through Mike.....	15
Editorials, Indi-Gest and Condensed by Dielectric.....	16
The Do's and Don'ts of Antenna Construction, Part III—Construction of Outdoor Masts, by William Fenwick.....	17
"Traveler" Doughnut Coil Tuned R.F. Receiver, Part II—Drilling and Assembly, by John G. Ryan.....	19
A. B. C. Course in Radio Fundamentals, Chapter XXX—Applications of the Electron Tube Oscillator—Continued, by David Penn Moreton.....	20
Complete Data for British Circuit.....	21
Questions and Answers.....	22
Directory of Radiophone Broadcasting Stations, Part III.....	23

Looking Ahead

The Days of Wild Goose Chases around the dials are fast disappearing. Radio fans now pick their selections in much the same manner that they formerly chose a record to play on the talking machine. To aid the fans in their selection of the numbers there will be a new program index system installed in the next issue. This will tell you exactly at what hours and where you can hear women's talks, dance music, including the orchestra's name, and classic and popular concerts and who gives them.

We Dimly Remember Milwaukee having been made famous by something other than a broadcasting station, but what it was has slipped our mind. However, the fame of the past is being supplanted by that brought on by Station WHAD of the Milwaukee Journal and Marquette university. The persons who make it go and the things with which they make it go will be described in picture and story next week.

Super-Heterodyne Fans Will Be Pleased with the Grand Prix receiver to be described in a series of articles by James McDonald, the first of which, "What Is in It and Why," will be printed in next week's edition. Watch for this series, and if you wish a set that will reach out for real DX, be prepared to build the Grand Prix.

The Five Tube R.F. Fans will be told how to wire the "Traveler," John G. Ryan's contribution to the deluxe sets of the year. Different colored covered wire and numbers on each wire and connection will insure you against hooking up wrong.

Newsstands Don't Always Have One Left

WHEN YOU WANT

Radio Digest

YOU WANT IT!

BE SURE OF YOUR WEEKLY COPY BY SUBSCRIBING NOW

SEND IN THE BLANK TODAY

Publisher Radio Digest, 510 N. Dearborn St., Chicago, Illinois.

Please find enclosed check M. O. for Five Dollars (Six, Foreign) for One Year's Subscription to Radio Digest, Illustrated.

Name

Address

City State

Radio Trust Probe Is to Start October 20

WASHINGTON.—The Federal Trade commission has set October 20 as the date on which to begin hearings in New York city in connection with its case against the Radio Corporation of America and others as an alleged monopoly.

Edward L. Smith will be chief attorney for the commission and David H. Sibbett will sit as examiner in the case. It is expected that the taking of testimony in New York will take several weeks, following which hearing will be held in other cities which have not yet been decided upon.

A naval officer connected with the Radio service of the navy department has been requested by Secretary of the Navy Wilbur to attend the Federal Trade commission's hearings in New York. The commission has requested the secretary to make such information available to it as seems desirable. Both the army and navy are more or less interested in these hearings inasmuch as it has been contended by officials of the Radio Corporation of America that the organization was originally begun at the request of the navy department at the conclusion of the war.

New Toronto Air Voice to Divide Time with Old One

TORONTO.—New call letters from Toronto were heard recently when CKNC, Canadian National Carbon company, took the air for the first time. A splendid program was prepared for the inaugural, including selections by the CKNC Salm orchestra, a vocal quartet, an instrumental trio and a number of soloists.

The station in the future will use part of the time schedules allocated to CHNC, Toronto Radio Research society. CHNC's studio and station is located in the Canadian National Carbon company's plant. Mr. Combs, who directs CHNC, will also direct CKNC.

GIANT BRITISH STATION

(Continued from page 1)

the tapping key under the finger of a man at the general post office.

Five other stations are being built in Britain simultaneously with Rugby. They are Bodmin, Bridgewater, Skegness, Grimsby and Dorchester.

Under a recent arrangement the government is keeping in its own hands all communications with the colonies, while allowing private enterprise to link Britain up with foreign countries.

A novel program illustrating the growth of ragtime from the syncopated negro spiritual and song up to the present day was transmitted from Station 2LO. Old favorites like "Alexander's Ragtime Band," and "Whistling Rufus" were broadcast.

STATEMENT OF THE OWNERSHIP, MANAGEMENT, CIRCULATION, ETC., REQUIRED BY THE ACT OF CONGRESS OF AUGUST 24, 1912.

Of Radio Digest, Illustrated, published weekly at Chicago, Ill., for October 1, 1925.

State of Illinois, County of Cook, ss.—Before me, a notary public in and for the State and county aforesaid, personally appeared E. C. Rayner, who, having been duly sworn according to law, deposes and says that he is the publisher of the Radio Digest, Illustrated, and that the following is, to the best of his knowledge and belief, a true statement of the ownership, management (and if a daily paper, the circulation), etc., of the aforesaid publication for the date shown in the above caption, required by the Act of August 24, 1912, embodied in section 443, Postal Laws and Regulations, printed on the reverse of this form, to-wit:

1. That the names and addresses of the publisher, editor, managing editor, and business manager are: Publisher, E. C. Rayner, 2335 Commonwealth Ave., Chicago, Ill.; Editor, Evans E. Plummer, 934 Lawrence Ave., Chicago, Ill.; Managing Editor, None; Business Manager, V. E. Huffer, 5220 Cornell Ave., Chicago, Ill.

2. That the owner is: (If the publication is owned by more than one individual his name and address, or if owned by a corporation the name of the corporation and the names and addresses of the stockholders owning or holding one per cent or more of the total amount of stock should be given.) E. C. Rayner, 2335 Commonwealth Ave., Chicago, Ill.; George Seaman, 2350 Parkway, West Chicago, Ill.; F. T. Ryan, 510 N. Dearborn St., Chicago, Ill.; D. R. Seaman, 49 Cedar Ave., Chicago, Ill.; Joseph Seaman, 200 Fifth Ave., New York, N. Y.; V. E. Huffer, 5220 Cornell Ave., Chicago, Ill.

3. That the known bondholders, mortgagees, and other security holders owning or holding 1 per cent or more of total amount of bonds, mortgages, or other securities are: (If there are none, so state.) None.

4. That the two paragraphs next above, giving the names of the owners, stockholders, and security holders, if any, contain not only the list of stockholders and security holders as they appear upon the books of the company but also, in cases where the stockholder or security holder appears upon the books of the company as trustee or in any other fiduciary relation, the name of the person or corporation for whom such trustee is acting, is given; also that the said two paragraphs contain statements embracing affiant's full knowledge and belief as to the circumstances and conditions under which stockholders and security holders who do not appear upon the books of the company as trustees, hold stock and securities in a capacity other than that of a bona fide owner; and this affiant has no reason to believe that any other person, association, or corporation has any interest direct or indirect in the said stock, bonds, or other securities than as so stated by him.

5. That the average number of copies of each issue of this publication sold or distributed, through the mails or otherwise, to paid subscribers during the six months preceding the date shown above is: (This information is required from daily publications only.)

E. C. RAYNER, (Signature of publisher.)

Sworn to and subscribed before me this 2nd day of October, 1925.

(SEAL)

A. C. MCKITTRICK,

(My commission expires October 1, 1928.)

KDKA ADDS COURSES TO ITS AIR COLLEGE

MORE LIKE UNIVERSITY AS SCHEDULE GROWS BIG

Poultry Raising, Physics, Crime, Radio, Travel, All to Be Covered in Special Courses

PITTSBURGH.—Radio colleges are not uncommon on the air nowadays, but Station KDKA here, can now qualify for the name of "university of the air" as it is broadcasting work in different collegiate lines on regular schedule. A series of courses especially designed for those interested in agriculture and home economics are given in cooperation with the Pennsylvania State college and the National Stockman and Farmer. Other series, prepared by faculty members of the University of Pittsburgh, will deal with physics, criminology, travel, and Radio.

Poultry Comes First

Poultry keeping will be the first of the Radio courses to be offered in cooperation with the State college and the Stockman and Farmer during the coming winter.

A member of the college correspondence department will explain the course and give instructions for enrolling at the October 15 farm program from the Stockman and Farmer studio, and the lectures will begin the following week. This course will extend over eight weeks. It will be given by the different poultry specialists at the college, one instructor giving a lecture on feeding, another on diseases, and still another on other subjects that will be taken up in the course.

Another course will be given as soon as the poultry course is finished. Various specialists of the college are now engaged in preparation of the Radio correspondence lessons. Each of the talks presented in the courses will be written and given by an authority on the particular subject.

The Physics Series

The Physics department, University of Pittsburgh series, will be broadcast as follows:

Tuesday, October 20: "The Nature of X-Rays," Dr. Worthing.

Tuesday, October 27: "Crystal Structure," Dr. Sieg.

Tuesday, November 3: "Structure of the Atom," Dr. Sieg.

Tuesday, November 10: "Relativity," Dr. Sieg.

Criminology Series Too

"Criminology" is the subject of the second series. Dr. W. T. Root, Jr., will give this series treating the subject from the point of view of the causes, control and treatment of crime.

The remaining lectures are:

Wednesday, October 21: "The Cause of Crime."

Wednesday, October 28: "The Feeble-minded Offender."

Wednesday, November 4: "Historical Development of Penal Institutions, Reform and Punishment."

Wednesday, November 11: "The Essentials of Prison Reform."

A university travelogue will be broadcast on Thursday evenings during October.

An added feature to the university broadcasts this year will consist of Radio chats to be given every other Friday night by Prof. George A. Scott, who conducts the Radio courses given by the department of physics at the university. The purpose of Professor Scott's talks will be to instruct in fundamentals of Radio and to discuss in a popular way the general problems connected with it.

The university studio will continue its policy of issuing, at the conclusion of a series, Radio publications containing the talks just as they have been given over the Radio, together with lists of suggested reading references for those who may wish to do further study.

Oklahoma City Plans Large New Broadcasting Station

OKLAHOMA CITY.—The prospect that Oklahoma's voice will soon be on the air again louder and more powerful than ever loomed bright here recently, when directors of the Oklahoma state chamber of commerce, meeting here, voted to inaugurate a campaign to finance the \$200,000 budget needed to give the state a 5,000-watt station equal to the best Radio broadcasting centers in the country.

New Amateur Call Book

WASHINGTON, D. C.—The Radio section of the department of commerce has just published a list of amateur and special land Radio stations as of June 30, 1925. These may be secured from the government printing office for 25 cents in coin or money order.

WHOA, ORGAN, WHOA IS OFT HEARD ORDER

CHICAGO.—"Whoa, Organ, stand still," is the command often given to the studio organ by Frank Westphal, director of the All-American station, WENR, here, while filling a request number on this popular instrument. The swelling notes of the mighty organ that Radio fans enjoy come from an instrument no larger than an ordinary suitcase. In fact, the instrument is intended for portable use and when Mr. Westphal pedals vigorously, the organ starts to move across the studio.

COYOTE HEARS CALL OF WILD OVER RADIO

DENVER.—And now KOA, the Rocky Mountain broadcasting station, has had a coyote added to its host of listeners. Kenneth Buchanan, a university student in Salt Lake City, has informed the station that he and his pet coyote (named Oscar for some undisclosed reason), are regular listeners to this station. Kenneth says he and Oscar are reminded of their home in the wilds of western Colorado every time they tune in on a program and that Oscar begs to go back home again.

LISTENERS HEAR 1,000 FEET DOWN

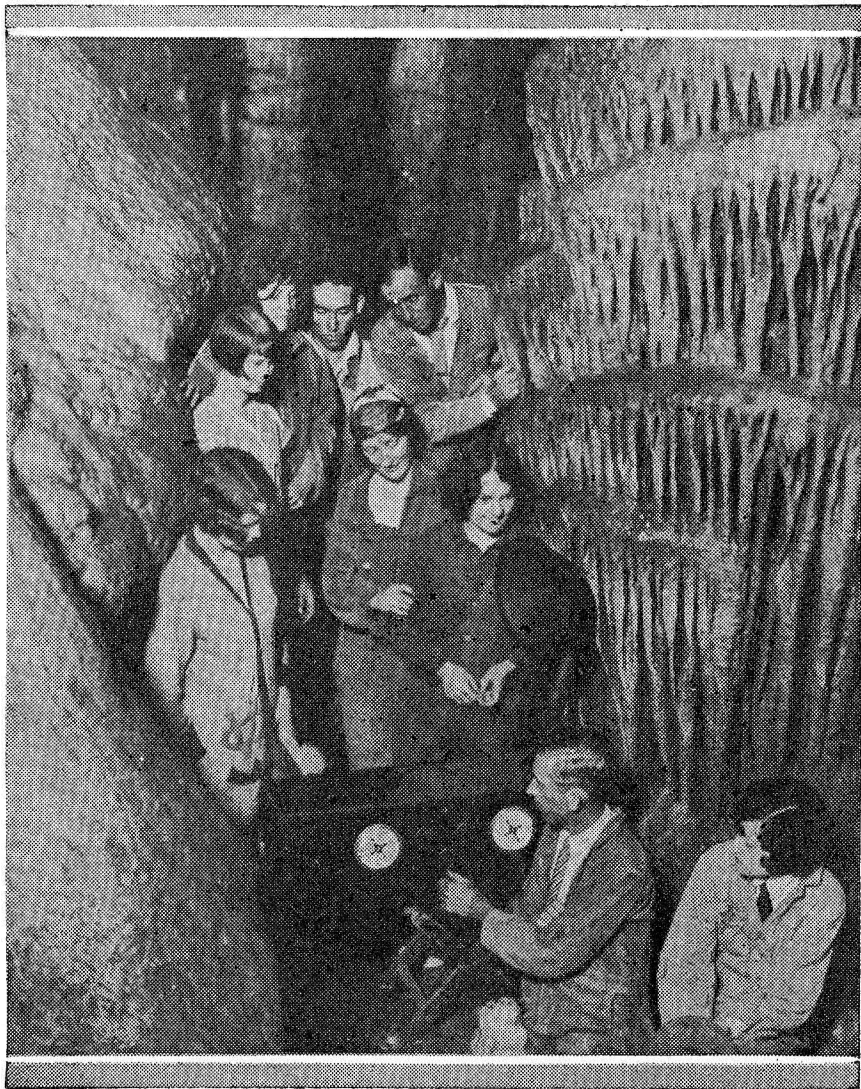

HOT SPRINGS, Ark.—Breaking into the silence of the centuries, strains of Radio music and the voice of the announcer of KTHS, the New Arlington hotel, Hot Springs National Park, on the night of October 10, furnished a weird thrill to a Radio party grouped around the loud speaker 1,000 feet underground in the famous Diamond Cave, near Jasper, Ark.

The special test program was put on by the New Arlington hotel station in cooperation with Mr. J. A. Cantrell, dean of Radio fans of that section, who has the distinction of having owned one of the first two sets operated in Arkansas.

The photograph showing the members

of the Radio party tuning in to Hot Springs was taken a mile and a half back of the entrance and 1,000 feet down. The assembling of the equipment and placing it for the test was a difficult undertaking, as in some places there is barely room for one person to walk. Mr. Cantrell is shown in the foreground tuning in.

He took tests from several sections of the cave after the Radio party broke up, and expects to compile his observations for general and scientific use.

Diamond Cave is considered by many experts to hold first place in this country for beauty. The test was arranged through the cooperation of Burton Bunch of Lead Hill, Ark.

New Stations

Illinois adds two new stations this week to its already overflowing quota. WJAZ, a 1,500-watt broadcaster owned by the Zenith Radio corporation, has its superpower station at Mt. Prospect. The wave length is 322.4 meters. The William Gushard Dry Goods store at Decatur opens a 500-watt station operating on 270 meters.

Detroit added another superpower station to its list last Saturday night, when WGHP went on the air with 1,500 watts. On a wave of 270 meters, once again the voice of C. D. Tomy, long famous as chief of the Red Apple club and manager of WCX, may be heard. He is the chief announcer of this new station.

Other new broadcasters of the week are: KTBR, Portland, Ore., 50 watts, 263 meters; WDCH, Hanover, N. H., 100 watts, 256 meters; WFRL, Brooklyn, N. Y., 100 watts, 205.4 meters; KFXM, Beaumont,

Tex., 10 watts, 227 meters; WPRC, Harrisburg, Pa., 100 watts, 215.7 meters.

KFBU of Laramie, Wyo., recently reported off the air, has renewed its license. WFKB, a 100-watt Chicago station which has a good record for distance, has increased in power to 400 watts. The University of South Dakota has the new call, KUSD.

KFRU, the 500-watt station located at Bristow, Okla., has changed ownership. This broadcaster is now operated by Stephens College, Columbia, Okla. The wave length is 506.

Crosley Heads International Week

CINCINNATI.—Powel Crosley, Jr., has been appointed chairman of International Radio week. Tests will be conducted in broadcasting between Europe and America in the week beginning January 26. The new American superpower stations should result in better reception than has ever before been attained in transoceanic broadcasting, according to a statement made by Mr. Crosley.

'ARCTIC FROM AIR' IS MACMILLAN SPEECH

SEVEN STATION LINK TO GIVE EXPLORER'S TALK

Will Tell of Extensive Airplane Trips Over Frozen Near-Pole Snow-clad Lands

NEW YORK.—Capt. Donald B. MacMillan, who represented the United States in his recent expedition to the far north, will give his thrilling lecture, "The Arctic From the Air," on Sunday, October 18, at 7 p. m., eastern time, from WEAF, New York, and six other stations. This chain will consist of WEEL, Boston; WCAP, Washington; WJAR, Providence; WWJ, Detroit; WCTS, Worcester, Mass., and WCAE, Pittsburgh, Pa.

The name of Donald B. MacMillan is familiar to all who read the newspapers or use the Radio. Since his first trip with Peary, he has repeatedly returned to the north and many thousands have heard his thrilling stories and have seen his motion pictures taken at the top of the world. During his winter in Baffin Land in 1921-22 and in North Greenland in 1923-24, he was the first Arctic explorer to use Radio and thousands of members of the Amateur Radio league of America listened in for his messages.

Used Planes Extensively.

The MacMillan expedition this last summer made extensive use of the airplane in exploration. Throughout the entire time they were in touch with civilization by means of their Radio equipment, giving detailed descriptions from time to time of their adventures. The expedition which left Wiscasset, Me., in June had for its purpose the exploration of the vast unknown space between the north pole and Alaska.

It was under the auspices of the National Geographic society with the cooperation of the U. S. navy department, the latter furnishing three giant planes of the new amphibian type with pilots and mechanics to man them. These were carried north by the S. S. Peary, MacMillan's new ship which was built in France for a mine-sweeper, but never used for this purpose. It was accompanied by the schooner Bowdoin, used in MacMillan's two previous trips. The Radio audience have a treat in store for them in the explorer's first talk since his return.

NOVEMBER 9 IS DATE SET FOR RADIO MEET

Hoover Calls Conference on Principal Broadcast Problems

WASHINGTON, D. C.—The fourth annual Radio conference has been officially called by Secretary of Commerce Hoover to convene in this city on November 9.

"The conference has been called," says the secretary, "for general discussion and consideration of matters affecting Radio communication in the United States from the viewpoint of the public interest. The conference will include representatives of all Radio activities. While consideration will be given to Radio activities generally, the principal problems will be those affecting broadcasting."

WFAV Former Programs Heard from Station KFAB

LINCOLN, Neb.—The Buick station here is now operating its new 1,000-watt transmitter. Another item of interest is the discontinuance of WFAV of the University of Nebraska and the broadcasting of all university programs through KFAB.

This includes five daylight programs and one evening program. The evening program is scheduled for Tuesday. The most important feature of fall broadcasting will be the play-by-play broadcast of all University of Nebraska football contests.

Sports Editor Teacher of WSB Radio Sunday School

ATLANTA, Ga.—Since The Atlanta Journal station, WSB, here, began relaying the Agoga class program every Sunday morning at 9:30 from the Baptist Tabernacle, Sunday schools throughout the daylight range of "The Voice of the South" have begun calling off their own programs and tuning for the Atlanta exercises, which are led by Morgan Blake, Journal sports editor and evangelist.

KTCL Specializes on Parades

SEATTLE, Wash.—KTCL, "The Charmed Land" broadcasting station here, have taken it upon themselves to broadcast parades. Both the Fourth of July and the Knight Templar's parade were broadcast by KTCL. They were voted successes, especially by listeners from sick beds, who had not heard parade music for years.

NEWS BRIEFS FROM THE BROADCASTERS

SARAGOSSA SEA ANIMALS SUBJECT OF LECTURE

Texas Comes to Georgia; Galaxy of Stage Stars to Be Heard from KOA Soon

Strange animals met on the Beebe expedition to the Saragossa sea will be described from KDKA by J. F. W. Pearson of the University of Pittsburgh and a member of the expedition, on two Thursdays, October 15 and 22. The Saragossa sea has long been the mystery spot of the Atlantic.

Fans tuning in for WSB lately were surprised to hear the "Hired Hand" of WBAP announcing. He also amazed Atlanta by arriving at the head of a delegation of 500 Texans, all wearing five-gallon sombreros and armed with cowbells.

A galaxy of stage professionals under the auspices of the widely known Denver Community players will appear at KOA Friday, October 23, in a headliner program of dramatic presentations. They are E. J. Reed of Mrs. Fiske's company; John Conneroy, who played with John Barrymore in Hamlet; Katherine Ommanney, dramatic coach at North Denver high school; Jessie Pringle, formerly with Frank Bacon in "Lightnin'," and Roy Bankson and Sidney Morris, ex-motion picture directors. The plays to be given are: "The Man in the Stalls," "The Wonder Hat" and "Her Tongue."

Lambdin Kay of WSB is not only popular with listeners but he is also liked by other announcers. The week of October 12 he was heard in St. Louis. Monday, October 13, he hopes to arrive in Chicago and take charge of George Hay's microphone at WLS while the latter is spending the week with Ford and Glenn at WFAA, Dallas, Texas.

The Sunday schedule of WOC has been changed so that the Atwater Kent opera program at WEAJ may be included. WOC church services commence at 6:30 p. m., central time, instead of 8. The concert by the Little Symphony orchestra now begins at 9:45.

The Burroughs Adding Machine company has announced another special concert Wednesday evening, October 21, from WJR, the Detroit-Pontiac station. Many unusual vocal, orchestral and harp combinations will be heard.

The pleasing music of the Marshall Field and company string quintet heretofore only heard by late shoppers in the tea rooms of this big department store may now be enjoyed by fans tuning for WGN, Chicago, between 4 and 4:30, central time.

Eight characters of the city and ten people from a small town, all members of the KGO dramatic players, will tell the story of "The Fortune Hunter," Winchell Smith's famous stage play, before the KGO microphones Thursday night, October 22, between 8 and 10 p. m., Pacific time.

The Rev. Dr. S. Parkes Cadman, pastor of the Central Congregational church of Brooklyn, N. Y., has resumed his popular Sunday afternoon series of addresses at the men's conference in the Bedford branch, Y. M. C. A., in Brooklyn. The program begins at 3:45 p. m., eastern time. The addition of WEEI, Boston; WCTS, Worcester, Mass.; WCAB, Pittsburgh, and WSAI, Cincinnati, to WEAJ means a great extension of Dr. Cadman's audience.

From WOR comes announcement of the addition to their regular Monday evening programs of Frances Williams and Al Wohlman who are now featured in conjunction with a half hour of concert music from 7:30 to 8 p. m., eastern time, by Eddie Elkins' Ciro orchestra playing direct from the Smart Supper club on West Fifty-sixth street, New York city.

The 1925-1926 season opens up at Westinghouse Station KYW with a number of attractions that appeal to the listener in. One of the stellar features that will be an exclusive one with KYW is the Loos Brothers harmony pair, whose singing and playing in the past has never failed to strike the responsive chord of their Radio audience.

Archie Slater's Palais D'Or orchestra has opened its fall and winter season at WOR and will be heard regularly again on each late Monday evening program.

In order to satisfy the fans who found his verses given over the Radio real interesting, Eugene Konecky, WOAW poet laureate and announcer E-K, has had them printed in book form.

RADIO HYMN CHEERS MAN NEAR TO DEATH

CHICAGO.—As the strains of the hymn, "Safe in the Arms of Jesus," floated through the Radio in a home in Benton Harbor, Mich., on a recent Sunday, George Leroy Miller, 40, an invalid for sixteen years, in a wheel chair fourteen years and for nine years blind, passed on to the great beyond. The last words of the dying man were of thanks to the Lord that made Radio an instrument of service even in death. Shortly before he sensed that the end was near he requested his nurse to notify the Chicago Gospel Tabernacle of Station WHT and request the choir to sing his favorite hymn. The choir was immediately assembled and with all the fervor and feeling at their command sang the hymn. After it was finished Chaplain Paul Rader preached a short benediction, but Mr. Miller heard no more.

But How About Yodelers?

PITTSBURGH.—Did you ever hear of a location which in midsummer is free of static; where in the middle of July one may listen in on distant stations as undisturbed by this pest of Radio reception as on the most favorable winter night? Such a Utopian place actually exists. The place is on the slope of the famous Jungfrau mountain in Switzerland, a peak of the Bernese Oberland mountains.

Souvenirs Swamp KOA Radio Plant

Fans Reward Favorites with Everything from Toy Balloons to Gold Nuggets for Programs

DENVER.—Found! A souvenir hunter's paradise!

For instance, if your hobby is nicknacks such as toy balloons, pin cushions, foreign coins, pencils, pictures of bathing beauties or blotters—get a job at a broadcasting station.

On the other hand, yours may be a desire for complimentary tickets to dog shows, picnic resorts, theaters, cafes, dances, rodeos and county fairs. Still, however, the answer is simple—get a job at a broadcasting station.

Finally, if your souvenir hoarding fancy runs to metallurgy, gold nuggets, tin whistles, brass paper weights or galena crystals, then, according to the school of experience at Denver—KOA—get a job at a broadcasting station.

Persist in Showering Station

There are no ifs or ands about it, according to Radio experts. As long as broadcasting stations continue serving the public, listeners, they say, will continue singling out and awarding their favorite ethereal voice with a memento of one kind or another.

After ten months on the air, the Rocky Mountain General Electric broadcasting

station boasts a trunk full of listeners' tokens. Most valuable of these, it is said, is a gold nugget, believed to be the first souvenir of its kind ever sent to a broadcaster. Accompanied by an unsigned California letter yesterday, this nugget was extended "as a token of appreciation for KOA's fine programs."

Meanwhile, members of the Denver broadcasting staff admit they are in a quandary to know what disposition to make of an increasing flow of Radio keepsakes which includes flowers (waxed, artificial, cut and pressed), "good luck" stones, old coins, chewing gum, road maps, scenic views and a host of photographic snapshots showing listeners, their homes, receiving sets, canoes, dogs and children.

Lost Twenty Years; Found By Radio Music Programs

NEWARK, N. J.—Broadcasting of the Hotel Shelton dinner music is safely entrenched as a feature of WOR programs each evening during the "music while you dine" period from this New Jersey station.

Jacques Jacobs, director of the ensemble, brought to light an unusual story when he visited the WOR studio recently. Harry Jacobs, a nephew of the orchestra director, has been lost from his family for more than twenty years. Through the widespread influence of the Radio announcements of his uncle's name, Harry Jacobs and his family have been reunited. The music supplied by the Hotel Shelton ensemble is largely classical.

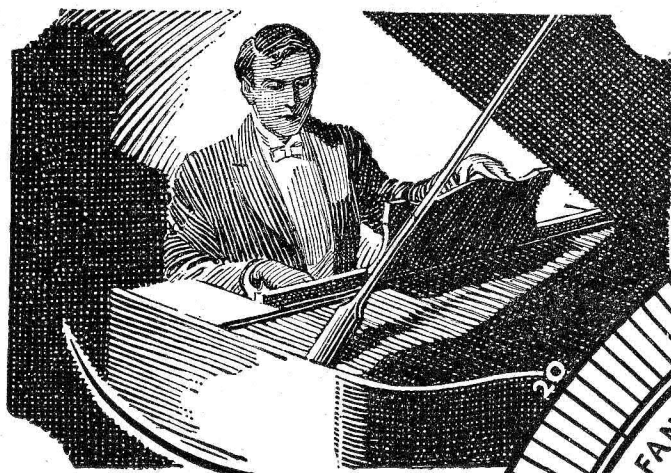

No Need to Wait for the Announcer — that's WGN

"Why, how can you tell? "Does it always come in at that exact point?"

"Is its number on the Day-Fan dial the same as the one in the newspapers?"

"And do they give you the Day-Fan dial number of every broadcasting station in that little Air Telephone Directory?"

"How easy! "I never knew any radio receiver could do that!"

"I thought you had to write the stations down as you found them!"

"That receiver must be more perfectly made than any other!"

It is. And after you have said or heard just such remarks as these, listen.

Listen to that announcer's voice—you can hear every intonation—the rustle of the paper in his hand.

Listen to that high, clear note of the flute!

Listen to that deep zoom of the bass violin—deep but clear, strong and sturdy, but never blurred.

No sound from the receiver itself.

Silence.

Then human voice.

Then true music.

So that you forget it happens to come through a radio, except when you tire of one program, and with a hand on the single dial, leap space to another, hundreds of miles away.

There is no radio receiver like the Day-Fan.

Any Day-Fan dealer will be glad to have you prove to yourself the truth of this statement.

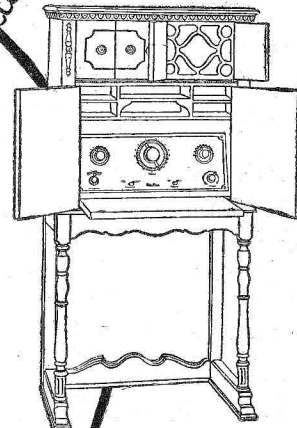

Above, the Day-Fan Dayroyal Radio Receiver with desk type cabinet—room for all batteries and wired for all equipment, including charger, \$300.00.

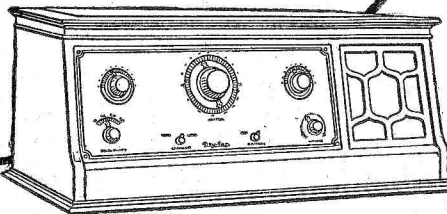

To the left, Daycraft, \$145.00. 5-tube single dial control, with dial carrying both Day-Fan Air Telephone Directory numbers and newspaper numbers. Self-contained Day-Fan loud speaker and room for B Batteries.

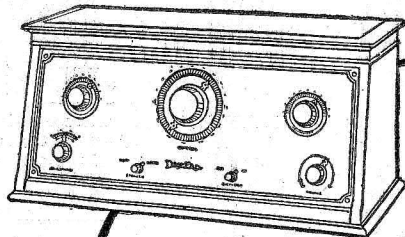

Day-Fan 5, 5-tube, single dial control. Dial carries Day-Fan Air Telephone Directory numbers and newspaper numbers. A remarkably fine radio receiver at a very low price, \$115.00.

THE DAYTON FAN AND MOTOR COMPANY
DAYTON, OHIO

For More Than 36 Years Manufacturers of High Grade Electrical Apparatus

Day-Fan RADIO

Station WJR, Detroit, "Where Joy Reigns"



Left, Howard E. Campbell, chief engineer and manager of WJR. Right, Leo Fitzpatrick, the "Merry Old Chief," newly appointed chief announcer of WJR.

Above, Deora Wolfe, studio hostess and regular accompanist. Right, Edward H. Jewett, president of Jewett Radio and Phonograph company, owners.

WJR, the 5,000-watt broadcasting station of the Jewett Radio and Phonograph company, has been on the air just two months, yet it has made many friends in the Radio audience. It expects to make many more. It has plans for the winter months that will undoubtedly make many more friends.

The station started broadcasting on August 15, a very unsatisfactory time to make any great impression upon the listening public. Even with this handicap, the station has been heard from coast to coast, and it is becoming one of the old reliables.

Just recently, Leo Fitzpatrick, who is known to hundreds of thousands of the Radio audience as the "Merry Old Chief," joined the staff of WJR as program conductor. Since then, his cheery voice and appropriate pleasantries have been heard regularly from the station. His ability and originality will always be an asset to the station's broadcasting. The policy of the station has been to give the public what it wants, when it wants it and the way it wants it. The mail received from the Radio audience has been the barometer of the program construction and the building of features since the station opened, and it will continue to be the guiding hand.

The station operates on a wave length of 517 meters—a wave length that is advantageously removed from other

bands on which high-powered stations operate, which, of course, facilitates in tuning in and giving the Radio public a chance to relax from the real careful tuning that is required on many of the wave lengths in the broadcasting band. The equipment used by the station is the latest 5,000-watt design. No detail has been neglected, either in the construction of the station, the remote control rooms in the Book-Cadillac hotel, Detroit, or the studios, which might make for greater ease and precision in handling the broadcasting which is sent out daily.

The manager and chief engineer of WJR is Howard E. Campbell, a man who has had many years of experience in both the commercial and broadcasting branches of Radio. He is an engineer of recognized standing. The assistant manager and program director is Corley W. Kirby, who was formerly Radio editor of a metropolitan newspaper and associated with one of the country's pioneer broadcasting stations.

Jean Goldkette, musical director of the station, has had a great deal of experience in arranging musical features for broadcasting stations, and has at his command the best musical talent available in or near Detroit. Miss Deora L. Wolfe, studio hostess and accompanist, is a thoroughly trained musician, a sympathetic accompanist and a pleasing personality around the studio.

For the benefit of the late listeners, WJR will inaugurate a midnight program in the near future, to be known as "The Jewett Jesters." It will be broadcast three nights each week—Monday, Wednesday and Saturday—with "The Merry Old Chief," the master of ceremonies, presiding over the microphone with his customary informality and wit which have made his midnight programs famous.

There will be nothing serious broadcast, except when the occasion demands, because the mission of the Jesters will be to spread joy and to broadcast the atmosphere of good fellowship that surrounds the meetings.

A new venture will be attempted by the Jesters in presenting a public appearance of the performers each Sunday night at Orchestra Hall. It will be for the purpose of acquainting the Radio listeners with the performers whose personalities they have become acquainted with over the Radio. A two-hour program of the highest type of entertainment will be offered each Sunday night on the stage, which will be converted into a replica of the WJR studios.

The gentleman at the microphone is Corley W. Kirby, program director and assistant manager of Station WJE which is located in Pontiac, Mich., but has its studios in the building at the left, the big new Book-Cadillac hotel at Detroit.



Above, Jean Goldkette, musical director of the Jewett Radio and Phonograph company's station, WJR, also director of his own orchestra. Below, two of the motor generators required to furnish power to the transmitting tubes, which are located in the room farther below, where you see the operator's desk, speech input equipment and part of the transmitter.

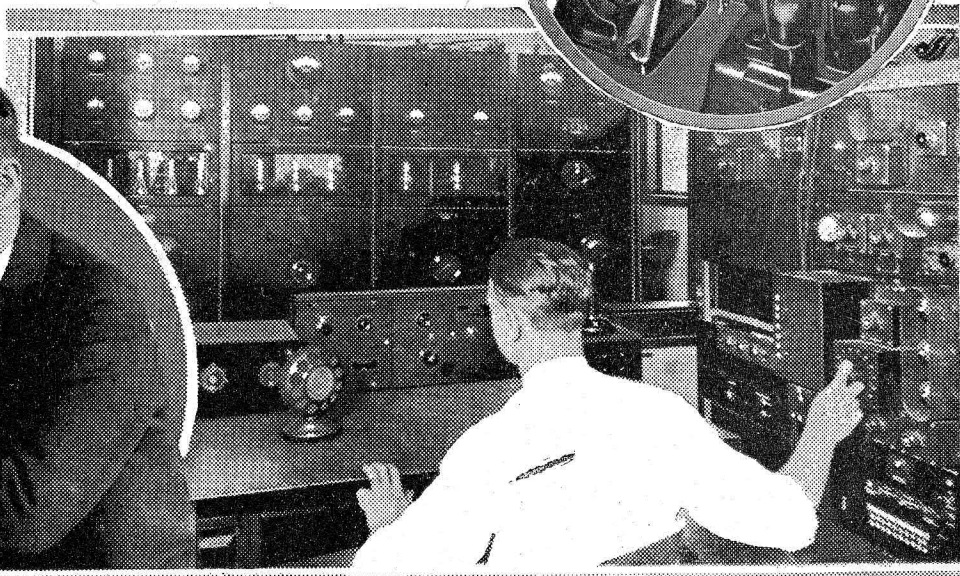
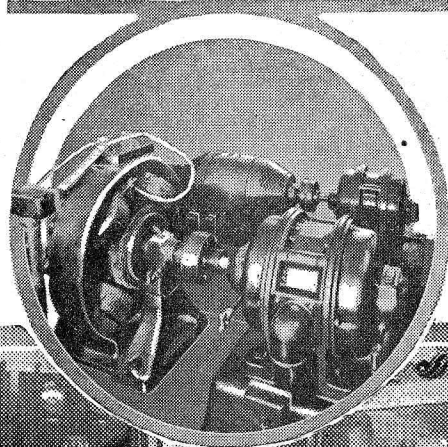
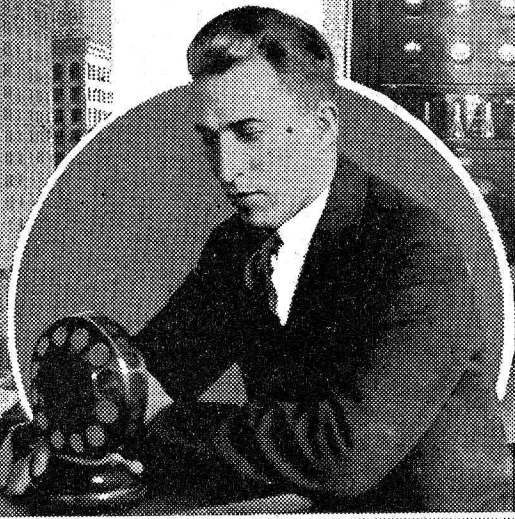

LONG RELAY TAKES GENEVA TO ENGLAND

LEAGUE OF NATIONS TALK HEARD IN BRITISH ISLES

Land Lines and Radio Plants Hook Up to Carry Political Talk All Over Europe

LONDON, Eng.—The first experiment in all-Europe broadcasting has just been carried out with singular success. Through the enterprise of the British Broadcasting company the most important of the proceedings at the present meeting of the League of Nations are being broadcast throughout Europe. This constitutes a unique record, and marks the beginning of an era which may place Radio in the forefront as a powerful influence in yet another sphere—that of international politics.

The first item broadcast from Geneva was M. Painleve's address. At Paris, the Eiffel Tower station broadcast the speech. This was again picked up at the B. B. C. experimental post at Hayes, sent by land line to 2LO and 5XX, and rebroadcast to listeners—a remarkable feat. In London it was possible to understand nearly every word of the talk.

Difficulties on Land Line

Difficulties in relaying on the long land line between Geneva and Paris were encountered, but recent experiences support the conclusion that relaying over long distances can have satisfactory results. For example, on August 23 the new Swedish station at Boden was relayed by land line to all Swedish stations, but also as far away as Copenhagen. Despite the distance the transmission had to travel by land line (1,100 miles), the reception was perfectly clear.

M. Painleve's address was also relayed to German and central European stations.

Scandinavian Hams Organize

COPENHAGEN.—The Radio amateurs in Scandinavian countries now possess an international organization covering the Baltic area, the S. R. R. L., or Scandinavian Radio Relay league, with headquarters in Stockholm. Membership is open to all amateur senders in Scandinavian countries.

FORSAKES MIKE FOR FOOTLIGHTS' GLARE

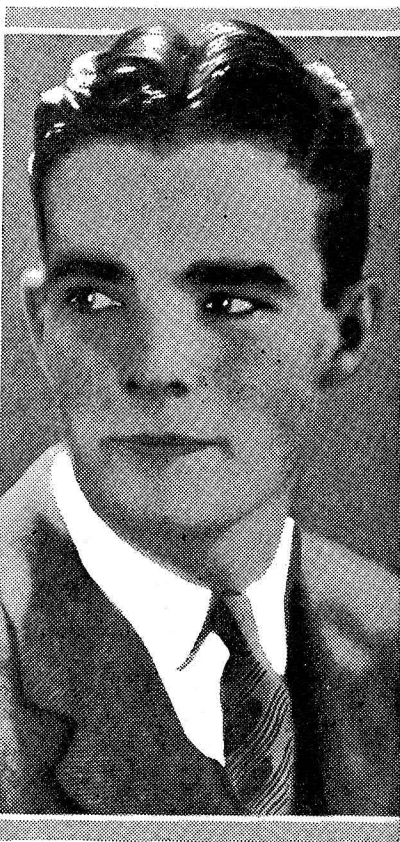

THE footlights have claimed another Radio favorite! Vernon (Tex) Rickard, popular tenor and assistant announcer at WGN, the Chicago Tribune station, for many moons, has forsaken the "mike" for grease paint and powder box, and as "George Shelby" is scoring a hit in the Duncan sisters' show, "Topsy and Eva."

Vernon, so charmed the "Duncs" with his singing of "Rememberin'," and others of the favorite songs from "Topsy and Eva" that they made "Tex" a full-fledged thespian. Rickard went through his first performance like a veteran, and the Dun-

Home Economics Course by Radio to Busy and Active Western Housewives

BECAUSE her daylight hours are split three ways by family responsibilities, business cares and club activities, the modern woman may shortly resort to Radio as first aid in solving her culinary and home economics problems.

This belief, as expressed by the broadcasting staff of KOA, General Electric station at Denver, is based on recent observations in connection with a newly inaugurated series of table talks for housewives.

The discussions are designed to provide timely hints on cooking and are heard as the closing feature of KOA's Tuesday, Thursday and Friday matinees.

Will Tell Art of Entertaining

Following widespread requests from women in many western cities and rural sections, announcement is made that the housewives' discussions will likely be enlarged before fall to include expert advice on entertaining in the home. Such a course would prove of special value during the winter social season, it is said. Courses in cookery over KOA are ar-

ranged by the Morey Mercantile company of Denver. They are given under the personal supervision of a prominent society and club matron of Denver, whose name, for the present, is being withheld and who speaks under the "Nom de Radio" of "Clara Hoover."

Radio Culinary Hints Define Cooking

"Culinary hints by Radio will do much to remove guesswork from cooking, if numerous comments from women are any criterion," Mrs. Hoover declares. "They will help the western housewife to cut down the number of hours she spends over a range or in a hot kitchen. Likewise they should prove a valuable aid in conserving energy and balancing menus—all without inflating the family budget."

Mrs. Hoover emphasized that her table talks were to be regarded by women as a supplement to text books and other publications devoted to cooking and domestic economics.

can sisters proclaimed their "find" from the housetops. He is now with the show making cities in the middle west.

Rickard was one of the most popular of the WGN artists. He proved himself equally at home in jazz, songs from light opera and musical comedy, and sensational ballads. His pleasing voice soon earned him a large personal following among Radio enthusiasts and requests like "let's have more Rickard" were found in every mail at WGN. The recognition accorded him by the Duncan sisters will doubtless be applauded by his large audience of listeners. He will probably broadcast from Radio stations in the cities where "Topsy and Eva" shows.



Patented Nov. 18, 1924

Windsor Loudspeaker Console

For EVERY Radio Set

A stunning piece of furniture that restores order in the room where you have your Radio! No more cluttered table-tops, nor litter of equipment under-foot.

No unsightly horn in evidence, either! This console has its own loudspeaker, in-built. It's out of sight, but with very apparent tonal superiorities. For it has the highest-developed type of unit. With horn built of special non-vibrating, extra-hard, ceramic material. Produces clear non-vibrant tone.



Non-Vibrant Ceramic Horn

The clearest tone producer on the market. Made of special composition which defeats vibration.

There's ample room for everything; space for largest A and B wet batteries—or battery eliminator—required for any home set; and for a big charging outfit, too.

Finished in mahogany, or walnut color. Dainty design of parqueterie on two front panels. Top, 38 in. x 18 in. Substantially built; the product of a 40-year-old furniture maker.

The price, forty dollars, is for the complete console and includes the loudspeaker horn and unit. Thousands of dealers are showing this artistic addition to home radio equipment.

Rear View—Set Hooked Up



Price, \$40 West of Rocky Mts., \$42.50

Windsor Furniture Co.
1434 Carroll Ave.
Chicago, Ill.

Dialog --essential for proper set performance

Your set is capable of far more than you are getting out of it! Five minutes of tuning after you have equipped your set with Dialogs prove this.

Smooth, easy vernier control, such as only Dialog can give, permits adjustment to the minute capacity variation necessary to successfully separate close stations. And there is nothing in Dialog to wear out! No extra drilling to install on any set.

\$1.25 with black bakelite knob and black dial plate.
\$1.25 with black bakelite knob and silvered dial plate.
\$1.50 with brown bakelite knob and gold finished dial plate.
0-100 or 100-0 dial readings.

—And the new WALNART Station Selecting CONDENSER

The Walnut Condenser is not a straight line wave length nor a straight line frequency—but, a station-selecting condenser! Exactly what you have hoped for. Uncrowds all the stations making it easy for anyone to turn to the right condenser setting for any station.

Put Walnut Station-Selecting Condensers in your set. Radio will mean more to you—from that day on.

WALNART ELECTRIC MFG. CO.
308 So. Green St. CHICAGO
"Makers of Good Goods Only"

.00025	\$4.00
.00035	\$4.25
.0005	\$4.50

YOU don't need "B" Batteries if you use the **FRESHMAN MASTER "B" Battery Eliminator**

Connects from any electric light socket right to your radio set;—that's all there is to it.

With the Freshman Master "B" Eliminator your set will always be supplied with constant and uniform power. Noiseless in operation; your reception will not be marred by the snap and crackle due to chemical action in "B" batteries.

A. C. Model \$20.00 for alternating current
Freshman Rectifying Tube is required for operation of the A. C. Model. Price - - - - - \$2.50

D. C. Model \$17.50 for direct current

Costs less than one-tenth of a cent per hour to operate.

Sold by **AUTHORIZED FRESHMAN DEALERS** only

Chas. Freshman Co. Inc.
Radio Receivers and Parts
FRESHMAN BUILDING
240-248 WEST 40TH ST.—NEW YORK, N.Y.
CHICAGO OFFICE — 2626 N. WASHINGTON BLVD.

FARMER TO BENEFIT BY NEW WLS CHANGE

LESS TIME ON AIR, BETTER PROGRAMS, NEW PLANS

Sears-Roebuck Foundation to Open 5,000-Watt Plant Soon to Serve Rural Districts

CHICAGO.—Less time on the air but better and stronger farm programs during the time on, is the keynote of the winter schedule of WLS, Sears-Roebuck station here, according to an announcement by Edgar L. Bill, director.

With its new 5,000-watt station ready for use within a month, the American farmer will receive an agricultural Radio service such as neither WLS nor any other station has been in a position to render heretofore, says Mr. Bill.

Better Market Reports

Market reports and weather forecasts will be greatly enlarged in the cold weather season, and only leaders in entertainment and farm information will find places on the station's winter program, designed mainly for the farmer.

A full-time staff of seven, assisted by suggestions and criticisms of the membership of the Radio Farmers Democracy, will build and execute this plan. So popular has the idea of the organization become that a branch of the democracy has been organized southwest of the cotton belt where the agricultural foundation broadcasts through Station WFAA at Dallas, Tex.

To Have New Studios

Simultaneous with the opening of the new superpower WLS at Crete, Ill., the station will also move into its new headquarters in the new Hotel Sherman. Here will be "twin" studios, a little theater and reception room for visitors, as well as the offices of the station.

Hardly a Handful

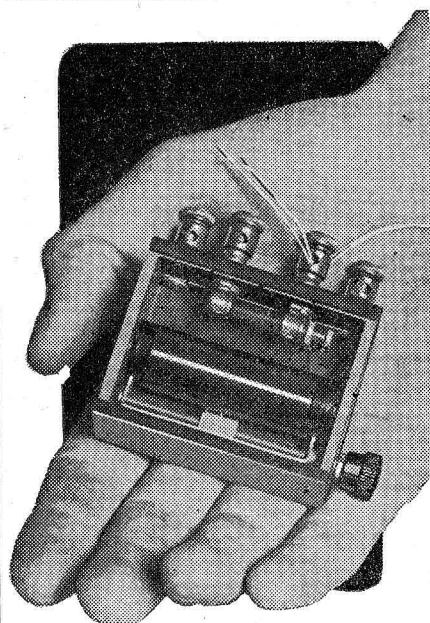

Women, too, entered sets in the prize contest for amateur set builders during the New York Radio World's Fair. This interesting miniature crystal set was built by Helen Giles, and it worked.

So This Is Venice

VENICE.—Radio amateurs in Venice have hit on a particularly bright idea; many of them, fortunate possessors of private gondolas, have fitted them up with receiving sets, and with small loud speakers, go floating about the canals of a moonlit night.

Kansas College Gives Credit in Air Course

High School and University Subjects Are Broadcast Regularly

MANHATTAN, Kan.—Station KSAC, the mouthpiece of the Kansas State Agricultural college, a pioneer institution in the harnessing of Radio for disseminating higher education, went on the air October 5 with an education program, a prediction of which would have appeared visionary a few years ago.

A rural schools program is scheduled at 9 o'clock each morning. It consists of opening exercises, a music lesson, talks on nature study, travel, lives of great men, books to read and current events. Five minutes are devoted to an agricultural primer, discussing in turn poultry, crops, dairying, horticulture and livestock. Calisthenics concludes the program.

High school credit courses are broadcast regularly, in addition to a football lecture course. A year's college credit may be earned through the courses which include general psychology, business English, community organization, educational psychology, economics, English literature, journalism, sociology, vocational education and educational sociology. Radio lectures are supplemented by home study and regular examinations are taken by the students under the direction of county superintendents.

Forty extension courses, covering the fields of agriculture, engineering, home economics and general science are given without college credit. Lecturers answer questions phoned to the station. Telephone exchanges have agreed to give their subscribers a certain number of free calls and the complete telephone conversation is broadcast.

Give the set a weekly sun bath to keep out the moisture.

RADIO TO HELP IN 'IRONSIDES' DRIVE

Station WEAF to Present Special Program to Assist During Constitution Week

NEW YORK.—In an effort to preserve the historic "Old Ironsides," the famous ship of the American Revolution, and to celebrate Constitution Week, WEAF will present an old Ironsides program on Saturday preceding (October 17) in which Robert Hilliard, distinguished Shakespearean actor and tragedian, and Secretary of the Navy Wilbur will make speeches in Washington, D. C., which will be heard from WEAF, New York, via direct lines.

Robert Hilliard is one of the best known actors of the old school and stage, and his recitation of the famous poem, "Old Ironsides," should stir the heart of every American.

Secretary Wilbur will make an appeal to the American people for funds to preserve for posterity the most famous ship in American history, which, at the present time, is rotting away in Boston navy yard.

"John Speaks for Himself" and Is Accepted via Radio

CAMBRIDGE, Mass.—A romance which spanned two continents and resulted in a Radio proposal and Radio acceptance culminated recently with the announcement of the marriage in Maine of John Alden, Jr., a Cambridge newspaper man, and Miss Margaret Thomas, daughter of the Rev. and Mrs. George H. Thomas of Chicago. Last week, while the steamship Samaria was heading toward Boston from Europe, young Alden, who is a son of the late John Alden, author, sent a Radio proposal of marriage to Miss Thomas. Miss Thomas sent acceptance winging through the air.

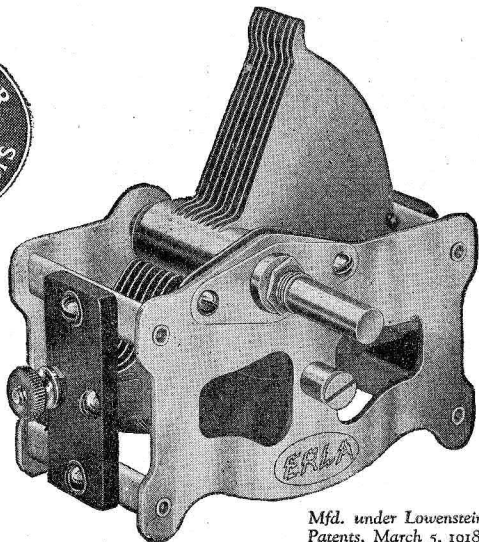

Mfd. under Lowenstein Patents, March 5, 1918.

Equi Space Gives Ideal Tuning at all Wave Lengths

Spreads low wavelength stations without crowding those from 50° to 100°. Lightweight and compact in style.

HERE is a new condenser that surpasses all present-day types. The conventional straight line frequency condenser spreads stations on the low wavelength proportions on the dial but it also brings stations between 50 and 100 too close together. On the higher wavelengths are many high-powered stations that are extremely difficult to separate.

The Erla *Equi Space makes allowance for this. It gives maximum spreads between stations over the entire range of the dial. Specially designed plates make this possible.

Now all stations, low frequency as well as high frequency, are spaced on the dial to insure the best results. Tuning is made far sharper. Sensitivity is greatly increased, reducing losses to an unprecedented minimum. Plates of special spring brass appreciably reduce bulk and weight, and tremendously reduce tendency toward misalignment from rough usage.

Special Erla Features

- Minimum capacity only 10m.m.f.
- Ratio of maximum to minimum capacity 35 to 1.
- Total resistance of only 3 ohms at 1000 cycles.
- Four riveted cross members supporting stator plates provide rigidity unapproached.
- Single-hole mounting makes it easy and quick to attach.
- Light weight plates of special spring brass appreciably reduce bulk and weight, and tremendously reduce tendency toward misalignment from rough usage.

Equi Space is small and compact, requiring little space. Very light but having extreme rigidity because of four riveted cross members.

Go to any radio store and see this amazing condenser today. It will make a striking difference in any set.

Send your name and address today and we will mail free, news of the latest radio discoveries and inventions.

*Trade Mark Registered
Electrical Research Laboratories
CHICAGO, U. S. A.

Electrical Research Laboratories, 7-A
2500 Cottage Grove Ave., Chicago, Ill.
Tell me what's new in radio.

Name

Address

City

County.....State.....

It's open season all the year

—for new and distant stations—with the whole radio world your preserve when you make

AERO-LOOP

your trail-blazer and path-finder

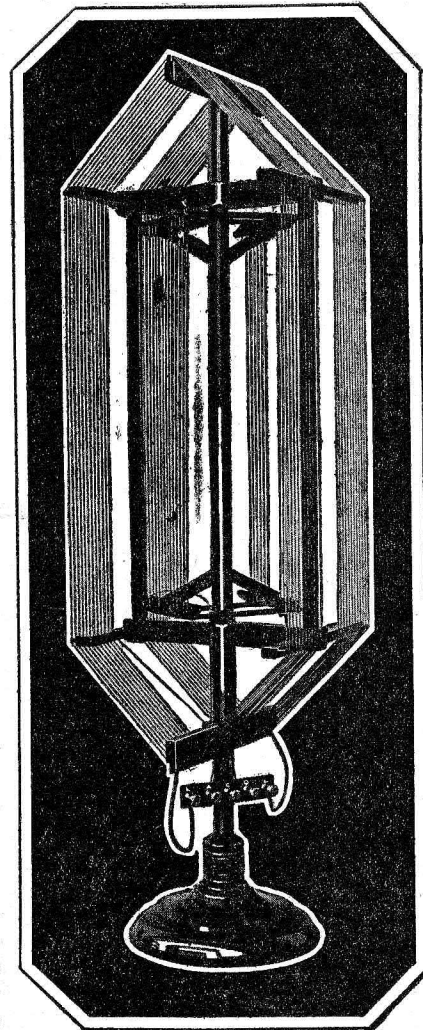

Now is the time to replace obsolete equipment with the "Loop-within-a-Loop" that is everywhere giving such marvelous results.

The stationary inner loop acts as a "booster" while the outer loop is adjusted by rotation.

Used with—or to replace—outside antennae.

Sells for \$12.50. Ask your dealer. If he does not carry it yet, we will ship direct, express prepaid, on receipt of price. Be sure to specify the set with which it is to be used and please give dealer's name.

Write for 12-page Descriptive Diagrammatic Aero-Loop Booklet. Your copy Free.

SCOTT SALES COMPANY
National Distributors
443 SOUTH SAN PEDRO STREET
LOS ANGELES, CALIFORNIA

UTT-WILLIAMS ELECTRICAL PRODUCTS CO.
SANTA ANA, CALIFORNIA

\$12.50

Beautifully finished in mahogany.
Dimensions 30 in. x 8 x 7 in.

HEAR LOUISE HOMER ON WEAF CHAIN

Sunday, October 18

(Continued from page 8)

KYW, Chicago, Ill. (535.4), 11 a. m., Central church service; Rev. F. F. Shannon, pastor; musical program, Daniel Protheroe, director; 4, concert, Edwin Harper, director; 7, Chicago Sunday Evening club; choir of 100 voices.

WAMD, Minneapolis, Minn. (243.8), 6 p. m., George Osborn's orchestra; 9:30, Marion Latta, contralto; Marie Fuller, pianist; Eldridge Meagher, musical saw soloist; George Donovan, tenor; 10:30, Radisson Rondevo.

WBBM, Chicago, Ill. (226), 4-6 p. m., Harmony Girls; Edith Carpenter, Grace Ingram, Frank G. King, Jr., and his Yankee band, Charlie Garland, Nate Caldwell, Eddie Loftus, Corrine Jordan, Blue Deuces, Harold Anderson; 8-10, Frances Ingram, Metropolitan opera contralto; Joseph Raife, duo art pianist; Jeanne St. Anne, French baritone; Ted Coleman, cellist; Sunset male quartet; 12-2, Nutty club.

WCAU, Philadelphia, Pa. (277.6), 5 p. m., Hope Craig Wynkoop, pianist; 5:15, Radio church service, Rev. John V. Stockwell; 5:25, Second Gospel book, Rev. John V. Stockwell; 5:35, recital; 5:45, "Making the Best of Things," Rev. John V. Stockwell; 6, Pennsylvania hotel concert orchestra.

WCBD, Zion, Ill. (344.6), 8 p. m., mixed quartet, brass quartet; J. D. Thomas, soprano; M. P. Barton, tenor; Mrs. Thomas, soprano; Mrs. LaRose, contralto; vocal trio; George Beem, Carl Newcomer, marimba duo; Susie Barton-Smith, reader; Josephine Martin, pianist.

WCCO, Minneapolis-St. Paul, Minn. (416.4), 10-20 a. m., Plymouth Congregational church; 4:10 p. m., House of Hope Presbyterian church; 8:15 station WEAF, Atwater Kent program; 9:20, classical concert.

WDAF, Kansas City, Mo. (365.6), 4-5 p. m., Orpheus male quartet; 5-5:30, Sunday school lesson, Dr. Walter L. Wilson.

WEBH, Chicago, Ill. (370.2), 7-9 p. m., artist program.

WENR, Chicago, Ill. (266), 2-4 p. m., Rauland lyric trio; Russell Hendrickson, cellist; O. T. Norum, tenor; 9:30-11:30, All American Pioneers.

WFAA, Dallas, Texas (475.9), 6:30-7:30 p. m., Radio Bible class, Dr. William M. Anderson; 8-9, First Methodist, Episcopal church; 9:30-11, Durward Cline and his Collegians orchestra.

WGES, Oak Park, Ill. (250), 7-9 p. m., John Stamford, tenor; Franklin Horstmeier, bass; Marguerite Ray, contralto; Frances Barge, violinist; Elsie Barge, pianist; 11-2 a. m., Eleanor Kaplan, violinist; John Rankel, baritone; Ruth Kalthoff, soprano.

WGN, Chicago, Ill. (370.2), 1 p. m., program, Chicago theater; 9-10, Drake concert ensemble.

WHAS, Louisville, Ky. (399.8), 9:57 a. m., organ prelude; 10, Broadway Christian church; 4:30-5:30, Christ church choral service.

WHB, Kansas City, Mo. (365.6), 9:40-10:45 a. m., services, Linwood Christian church; Dr. Burr Jenkins, minister; 8-9:15 p. m., evening services; 11:15-1, organ selections, Morrell Moore; dance music, Gary's School of Dancing.

WHO, Des Moines, Iowa (526), 11 a. m., University church service; sermon, Dr. C. S. Medbury; 7:30-8:30 p. m., Beese-Hughes orchestra.

WKRC, Cincinnati, Ohio (422.3), 6:45 p. m., Walnut Hills Christian church; 10, Gene Schmitt, baritone; Walter Bridge, tenor; Merrell Schwarz, baritone; Gene Parazzo, pianist.

WLS, Chicago, Ill. (344.6), 6:30 p. m., Ralph Emerson, organist; 7, WLS Little Brown church.

WLW, Cincinnati, Ohio (422.3), 9:30 a. m., school, editorial staff of Sunday school, publication, Methodist Book concern; 11, services, Church of the Covenant, Dr. Frank Stevenson; 7:30 p. m., services, First Presbyterian church, Dr. Frederick McMillan, minister; 8:30, concert, H. & S. Pogue concert; Walter Esberger, director; soloist, George Muhlbauer.

WMBB, Chicago, Ill. (250), 3-5 p. m., Trianon orchestra, Dell Lampe, conductor; Billie Hoff, Walter Duffy, Geraldine Doyle, Woodlawn theater orchestra, Armin Hand, conductor; 7-8, Trianon duo, J. Bodewalt Lampe, director; Beatrice Teller, Hazel O'Neil, Joel Lay, Florence Rush, semi-classical program; 9-11, Trianon orchestra, Dell Lampe, conductor; Harold Stokes, Charles Agne, M. Alswang, Woodlawn theater orchestra, Armin Hand, conductor.

WOAW, Omaha, Neb. (526), 9 a. m., chapel service, Rev. R. R. Brown; 9, chapel service.

WOC, Davenport, Iowa (483.6), 6:30-7:30 p. m., church service, Rev. John L. Daleiden; 8:15-9:15, Atwater Kent Radio artists; 9:45-11:45, Palmer little symphony.

WORD, Batavia, Ill. (275), 9 p. m., hymns and sacred songs, I. B. S. A. choral singers; 9:10 address, B. F. Hollister; 9:30, Lela Hammer, pianist; I. B. S. A. choral singers.

WOS, Jefferson City, Mo. (440.9), 9:30 a. m., Christian church; 7:30 p. m., Presbyterian church.

WQJ, Chicago, Ill. (447.5), 9:30-11:30 a. m., sermon and service, People's church; 100 voice choir, Clarence Eddy, organist; 2-4 p. m., concert; Saïda A. Ballantine, artist; Elizabeth Green, violinist; Helen Keller, pianist; Bernice Smith, Mezzo-soprano; Paço Escalera, tenor; Garfield Steiner, baritone; Henri Biancali, cellist; Countess Vichy, contralto; Iola Juhl, soprano; 8-10, Ralph Williams and his Rainbo Gardens orchestra; G. B. Roe, baritone; Maude Couse, lyric soprano; Lavina Price, pianist; Sheppard Levine, soprano; Helen Reed, pianist; Sheppard Levine, soprano; Frederick Mueller, German tenor; Kathryn Diepenbrock, pianist and accompanist; Fontella trio.

WSAI, Cincinnati, Ohio (325.9), 2:45-4:30 p. m., address, Dr. S. Parkes Cadman; Gloria trumpeters; 7:45, address, Capt. Donald B. MacMillan, WEAF; 7:45, chime concert, Robert Badgley; 8, sermon, Rev. P. P. Love; 8:15-9:15, WEAF program, Mme. Louise Homer, famous contralto.

WSUI, Iowa City, Iowa (483.6), 9:15 p. m., Iowa City Welsh quartet.



Louise Homer, contralto of the Chicago Civic Opera company, is the guest, October 18, of Atwater Kent on the WEAF chain.

Iam Howie; Bobbie Riddle, 6 year old singer, clog dancer; program, Mrs. Gertrude May.

KPRC, Houston, Tex. (296.9), 7:30 p. m., Record's Ramblers dance orchestra; 8:15, Seger Ellis, Victor record artist; 8:30, Kiwanis glee club; 9:15, Humble Oil and Refining company band; 10, Frank Tilton, pianist.

KSD, St. Louis, Mo. (545.1), 9 p. m., Negro music, St. Louis branch.

KTHS, Hot Springs National Park, Ark. (374.8), 9-9:45 p. m., concert, New Arlington orchestra; violin solos, Lon Chassy; string quartet; 9:45-10, organ solos, Lawson Reid; 10-11, Rainbow Garden 555 frolic.

WAMD, Minneapolis, Minn. (243.8), 6 p. m., George Osborn's orchestra; 7, "A Trip Around the World, Sweden," Loreta Reitz Lundie, soprano; John Nyberg, tenor; Lawrence Berg, baritone; 10:30, Radisson Rondevo.

WBBM, Chicago, Ill. (226), 6-7 p. m., Stewart-Warner studio, Hattie Bell Shields, cellist; Doris Ryan, pianist; Lew Russell; Montmartre orchestra.

WCCO, Minneapolis-St. Paul, Minn. (416.4), 6:45 p. m., F. & R. Family; 7:30, Minneapolis Community fund talk; 7:45, poultry raising, lesson 1; 8:15, Hamlin Hunt, organist.

WDAF, Kansas City, Mo. (365.6), 6-7 p. m., piano tuning in number on the Duo-Art; dialect readings, C. M. Ragon; Tell-Me-a-Story lady; Trianon ensemble; 8-9:30, Ivanhoe band, Walter French, director; Ivanhoe glee club; address, Herbert Hoover; 11:45-1 a. m., Merry Old Chief, Carl Norberg's Plantation players; Ted Menu, organist; Eddie Kuhn's Kansas City Athletic club orchestra.

WFAA, Dallas, Texas (475.9), 6:30-7:30 p. m., Artie Collins and his orchestra; 8:30-9:30, Sears-Roebuck agricultural foundation program.

WHAD, Milwaukee, Wis. (278), 6-7 p. m., Arthur Richter, organist; 8-10, Marquette university studio program.

WHB, Kansas City, Mo. (365.6), 7-8 p. m., popular music, Sweeney orchestra.

WHO, Des Moines, Iowa (526), 7:30-8 p. m., program, advanced students of the Drake Conservatory of Music; 8-9, faculty program, Drake Conservatory; 11-12, Corn Sugar orchestra.

WKRC, Cincinnati, Ohio (422.3), 6 p. m., Alvin Roehr's Hotel Alms orchestra; 10, Freda Sanker's orchestra; 11, program, Robert B. Bentley Post, American Legion; 12, theatrical stars, Wesley Helvey's Troubadours.

WLW, Cincinnati, Ohio (422.3), 12:15 p. m., noon-day service, Rev. George H. Kase; 4, student recital, classes of Leo Stoffregen; 7, dinner hour concert, Hotel Gibson orchestra, Robert Visconti, director; 8,



Senora Lolita V. de Cintron of Lima, Peru, brings Latin romance with her when she sings at WTIC, Hartford. She wears her native dress and sings Spanish songs.

Monday, October 19

Monday, silent night for: CNRA, CNRC, CNRE, CNRM, CNRO, CNRR, CNRV, CNRW, CNRT, KFDM, KFMO, KFMY, KKH, KLDS, KTCL, KYW, WBBM, WCBD, WEAQ, WESH, WGB, WENR, WFI, WGBS, WGES, WGN, WHAS, WIP, WKAQ, WLS, WMAQ, WMBB, WOC, WORD, WQJ, WRC, WREO.

Eastern Time Stations

CHIC, Toronto, Can. (356.9), 10 p. m., Queen City Novelty instrumental troupe.

CKNC, Toronto, Can. (356.9), 8 p. m., Charles E. Bodley and his orchestra; Sydney Walsh, tenor; Charles Shearer, baritone.

KDKA, Pittsburgh, Pa. (309.1), 6:15 p. m., dinner concert; 7:45, "International Art," Homer Saint-Gaudens; 9, Spear's happy home hour.

WAHG, Richmond Hill, N. Y. (315.6), 7:30-7:45 p. m., Emma Keller May, soprano; 7:45-8, Heagney and Steele, songs; 8-8:30, Synchronophase trio; 8:30-8:45, Trainmen's trio; 8:45-9, Horace J. Taylor, reader; 9-9:15, Emma Keller May; 9:15-9:30, Heagney and Steele; 9:30-9:45, Trainmen's trio; 9:45-9:55, Synchronophase trio; 10-10:15, Synchronophase trio; 10:15-11:15, Glenn C. Smith's Paramount orchestra; 12-1 a. m., dance music.

WBBR, New York, N. Y. (272.6), 8 p. m., Jubilee entertainers; 8:10, World News Digest; 8:25, Jubilee entertainers; 8:35, Bible instructions; 8:45, Fred Franz, tenor; 8:55, Jubilee entertainers.

WBZ, Springfield, Mass. (333.1), 6:30 p. m., Margaret Tighe, organist; 7:05, Susan Bennett, pianist; George Dwight, baritone; Mabel Bennett, accompanist; 7:30, Capitol theater orchestra; 8, to be announced; 8:30, Lyman B. Cozzens, whistler; 8:45, French-English program, Juliette Houde, director; 10:05, Leo Reisman's Hotel Brunswick orchestra.

WCAE, Pittsburgh, Pa. (461.3), 6:30 p. m., dinner concert, William Penn hotel; 8, address, Pittsburgh Personnel association; 9, A. & P. Gypsies; 11, Loew's Aldine theater.

WCAU, Philadelphia, Pa. (277.6), 8 p. m., "Music Appreciation," Maude Hanson-Pettit; 8:10, R. Langdon Stewart instrumental trio; 9, Amsterdam Girl; 9:10, song hits, Danny Dougherty; 9:30, popular songs, Freedman & Travaline; 9:45, James Loughrey; 10, Jaffe's Collegians.

WCTS, Worcester, Mass. (268), 8 p. m., concert program.

WCX, Detroit, Mich. (517), 8 p. m., dinner concert, Book-Cadillac hotel; 8, musical program.

WEAF, New York, N. Y. (491.5), 4-4:15 p. m., Loraine Osborne, contralto; Winifred T. Barr, accompanist; 4:15-4:30, Margaret Williams, reader; 4:30-4:45, Sylvia D. Lyons, pianist; 4:45-5, "Book Chat," W. Orton Tewson; 6-7, dinner music, Waldorf-Astoria; 7-7:15, Ernest Wendell Nichel, whistler; 7:15-8:30, program, Mark Strand theater; direction, Joseph Plunkett; 8:30-8:45, Yee Lavnhurst, pianist; 8:45-9, Tower health talk; 9-10, music, A. and P. Gypsies; 10-10:30, "Your Hour"; 10:30-11:30, Ben Bernie and his orchestra.

WEAR, Cleveland, Ohio (389.4), 7 p. m., Allen theater orchestra.

WEEL, Boston, Mass. (476), 6:30 p. m., Big Brothers club; 7:15, music; 7:30, John E. Amherst, boy soprano; 7:45, Boston Chamber of Commerce organ recital; 8:30, J. Garfield Stone, tenor; 8:45, Tower health talk; 9, A. & P. Gypsies; 10, Marimba band and orchestra.

WGBS, New York, N. Y. (315.6), 6-6:30 p. m., Uncle Geebee; 6:30-7, Premier Club orchestra; 7-7:15, "New Astrology," Belle Bart; 7:15-7:45, orchestra.

WGCP, New York, N. Y. (315.6), 3-5:30 p. m., musical program; 8-11, musical program.

WGR, Buffalo, N. Y. (318), 2:30-4:30, 6:30-7:30 and 8:30-10:30 p. m., Buffalo Radio show program featuring the Erlenbach orchestra; 11-1 a. m., Vincent Lopez Hotel Stadler dance orchestra, Harold Gieser, director.

WGY, Schenectady, N. Y. (379.5), 6:30 p. m., Hotel Van Curler orchestra; 7:30, Mary Zoller, xylophonist; Erlau Wilcox, pianist; Henry Gratton, James Willis,

pianists; literary appreciation series, William L. Whiddemer.

WHAR, Atlantic City, N. J. (275), 7:30 p. m., stories for little folks, Mildred C. Hagan; 8, Seaside hotel trio.

WHN, New York, N. Y. (361.2), 7-7:30 p. m., Marlboro State trio; 7:30-8, Swane club orchestra; 8-8:05, talk, H. B. Shontz; 8:05-8:30, Roseland dance orchestra; 11-11:30, Marsh McCurdy, organist; 11:30-12, Silver Slipper revue and orchestra; 12-12:30 p. m., Ted Lewis and orchestra.

WJAR, Providence, R. I. (305.9), 8 p. m., Berry Spring time; 8:45, "Home Care of the Sick," Gertrude Harrop; 9, WEAF A. and P. Gypsies; 10, Robert W. Powers Hudson-Essex orchestra.

WJR, Detroit, Mich. (517), 7 p. m., studio orchestra, Jean Goldette; 9, "Paige Six and Jewett Six."

WLIT, Philadelphia, Pa. (394.5), 7:30 p. m., Dream Daddy; 9, Stanley Hour of Music; 10, Arcadia cafe dance orchestra; Fay's Knickerbocker theater.

WMCA, New York, N. Y. (340.7), 6-6:30 p. m., Oleott Vail and his Hotel McAlpin string ensemble; 6:30-7:30, Ernie Golden and his Hotel McAlpin orchestra; 7:30-8, lullaby music; 8-8:30, Louise Judson, soprano; Theodore Mattman, cellist; 9-10, lecture, Christian Science.

WNYC, New York, N. Y. (526), 7-7:10 p. m., market high spots; 7:10-7:30, Stony Brook orchestra; 7:30-7:35, police alarms; 7:35-8, Stony Brook orchestra; 8-8:30, German lessons, V. Harrison Berlitz; 9-9:15, piano soloist; 9:30-9:50, male quartet; 9:50-10:05, violinist; 10:10-10:30, lecture, board of education; 10:35-11:30, Harold Stern's Hotel St. George orchestra.

WOO, Philadelphia, Pa. (508.2), 8 p. m., Mark Strand theater; 8:30, Yee Lavnhurst, pianist; 8:45, Walter H. Preston, baritone; 9, A. and P. Gypsies; 10, your hour; 10:30, Ben Bernie and his orchestra; 11, Hotel Ritz Carlton orchestra.

WOR, Newark, N. J. (405.2), 6:15-6:17 p. m., "Words Often Mispronounced"; 6:17-7:15, music, Hotel Shelton; 7:15-7:30, sports talk, Bill Wathey; 7:30-8, Club City's orchestra; 8:30-9:30, Al Reid's hour; 9:30-9:45, talk, Edward H. Bierstadt; 11-11:30, Archie Slater's Palais D'Or orchestra.

WPG, Atlantic City, N. J. (299.8), 4:30 p. m., Chalfonte-Baddon hall afternoon tea music; 6:45, Arthur Scott Brook, organist; 7, Hotel Morton trio dinner music; 8, "World-Wide Excursions," Alfred James P. McClure; 8:15, studio program; 9, Hotel Traymore concert orchestra; 10, studio program; 10:30, Silver Slipper.

WRC, Washington, D. C. (468.5), 7 p. m., Shoreham hotel orchestra; 8, Wuritzer musicale, WJZ; 9, musical program; 10, "Over the Seven Seas—Life Aboard Ship," WJZ; 10:30, W. Spencer Tupman and his Hotel Mayflower orchestra, WJZ.

WTAM, Cleveland, Ohio (389.4), 8-11 p. m., excerpts from opera, "Pirates of Penzance"; favorite artists; Willard symphony; Walter Lozan, director.

WTIC, Hartford, Conn. (475.6), 6:30 p. m., Emil Heimberger's Hotel Bond trio; 7:45, talk; 8, dinner music.

WWJ, Detroit, Mich. (352.7), 3 p. m., Detroit News orchestra; 6, dinner concert; 8, Detroit News orchestra, A. & P. Gypsies.

Central Time Stations

KFAB, Lincoln, Neb. (340.7), 5:30-6:30 p. m., Buick Little symphony; Belshaw's orchestra; 8:30-10:30, American Legion program; Belshaw's orchestra; Mart Grauenhorst, banjoist.

KFNH, Shenandoah, Iowa (266), 7 p. m., Smith-Belding trio.

KFVE, University City, Mo. (240), 10 p. m., Margaret Gullhafer lyric soprano; Miss Netcher, accompanist.

KMA, Shenandoah, Iowa (252), 9-11 p. m., chimes, Wil-

Mountain Time Stations

KOA, Denver, Colo. (322.4), 10:55 a. m., First Unitarian society; 4 p. m., First Unitarian society; Mrs. Faye Roscoe, organist; 7:45, First Unitarian society.

KUOM, Missoula, Mont. (244), 9:15 p. m., English Lutheran choir; talk, Rev. Henry Kummick.

Pacific Time Stations

KFWB, Hollywood, Calif. (252), 9-11 p. m., late news and Warner Brothers movie; Charles Beauchamp, tenor; Babe Brown, ukulele; Frank Stever, baritone; Al Meyer's Aeolians; Frances St. George, the jazz-mania girl.

KGO, Oakland, Calif. (361), 11 a. m., Seventy-fifth anniversary service, First Unitarian church; 3:30 p. m., KGO Little symphony orchestra; 8, First Unitarian church.

KGW, Portland, Ore. (491.5), 10:25 a. m., First Presbyterian church; 7:25-9, First Presbyterian church.

KHJ, Los Angeles, Calif. (405.2), 6-7 p. m., Leighton's Arcade cafeteria orchestra, Jack Cronshaw, leader; 7-7:30, Arthur Blakely, organist; 8-10, de luxe program, arranged and presented by J. Howard Johnson.

KNX, Hollywood, Calif. (356.9), 2-4 p. m., City of Los Angeles, Westlake park; 7-8, First Presbyterian church, Rev. Stewart P. MacLennan, pastor; 8-9, Ambassador hotel concert orchestra, Josef Rosenfeld, director; 9-10:30, program, Beverly Hills nurseries, Russian string quartet, Calmon Luboviski, concert violinist.

KPD, San Francisco, Calif. (423.3), 5-6 p. m., Marshall Giselman, organist; 6, Waldemar Lind and the States restaurant orchestra; 6:35, concert orchestra, Palace hotel; 8, Palace hotel concert orchestra; 8:30-10, Rudy Selinger's orchestra.

KTAB, Oakland, Calif. (215), 10 a. m., Bible lecture, Prof. Linsley; 11, church service; 7:45 p. m., church service; 9:30, late concert.

KTCL, Seattle, Wash. (305.9), 7:50-9:10 p. m., First Church of Christ, Scientist; 9:10-10:10, International Bible Students association.

(Continued on page 10)

HELLO BOYS AMUSE LISTENERS AT WLW



Mrs. Sue Pearce pleases some fans by singing jazz and others by singing classical songs. She is, therefore, much in demand at KWKH.

Ben Bernie and his new Stradivarius are heard every Monday and Wednesday at WFAF. Lee Kent, right, is a titian-haired favorite at KFWB. She plays her ukulele Monday evenings.



Wednesday, October 21

(Continued from page 10)

- WHN, New York, N. Y. (361.2),** 7:30-8 p. m., Caravan club orchestra; 10-10:30, Roseland dance orchestra; 11-11:30, Silver Slipper revue and orchestra; 11:30-12, Ted Lewis and orchestra.
- WJAR, Providence, R. I. (305.9),** 7:30 p. m., U. S. Army band, WRC; 9, Waterman's Points of Progress, WFAF; 10, musical program.
- WJR, Detroit, Mich. (517),** 7 p. m., studio orchestra, Jean Goldkette, director; 9, Burroughs hour.
- WKAQ, San Juan, P. R. (340.7),** 7-9 p. m., municipal band, Prof. Manuel Tizol, director.
- WLIT, Philadelphia, Pa. (394.5),** 4:30 p. m., Rosemary Ulrich, soprano; 7:30 p. m., Dream Daddy's bedtime stories; 8, concert, General Electric company; 10, Arcadia cafe dance orchestra; Chas. Master's dance box orchestra.
- WMCA, New York, N. Y. (340.7),** 6-6:30 p. m., Olcott Vail; 6:30-7, Ernie Golden and his Hotel McAlbin orchestra; 8:45-9, "Lord Allinbroke and Rawstice," Jack Smiles; 11:30-12, Jack Smith, whistling baritone.
- WNYC, New York, N. Y. (526),** 7-7:10 p. m., market high spots; 7:10-7:30, dance program; 7:30-7:35, police alarms; 7:35-8, dance program; 8-9, Spanish lessons, V. Harrison Berlitz; 9-10, artist-pupil's recital; 10-10:30, piano duets.
- WOD, Philadelphia, Pa. (508.2),** 7:30 p. m., dinner music, Hotel Sylvania orchestra; 8, U. S. Army band; 8:30, Pooley period; 9, Waterman's Points of Progress, Napoleon; 10, Mary E. Vogt, organist; 10:30, Hotel Sylvania orchestra.
- WOR, Newark, N. J. (405.2),** 6:15-6:17 p. m., "Words Often Mispronounced"; 6:17-7:15, music, Hotel Shelton; 7:15-7:30, sports talk, Bill Wathey; 8-8:15, topics of the day; Spencer Armstrong; 8:15-8:35, Car-men string trio; 9-9:15, Sam Siegel, mandolinist; 9:30-9:45, talk, George W. Wadsworth; 11-11:30, Flo Richardson's Casino orchestra.
- WTAM, Cleveland, Ohio (389.4),** 8-9 p. m., Willard Ladies' ensemble; Nell Scheck, director; 9-11, instrumental music.
- WTIC, Hartford, Conn. (475.9),** 6:30 p. m., Hotel Bond trio and vocalists; 7:20, dinner music; 10, dance music, Bill Tasillo's orchestra.
- WWJ, Detroit, Mich. (552.7),** 6 p. m., dinner concert; 8, News orchestra; 9, dance program.

Central Time Stations

- CNRW, Winnipeg, Can. (384.4),** 8:10 p. m., Fort Garry hotel concert orchestra; 8:45, Transcona Shop's brass band; 9:45, supper dance, Fort Garry hotel; Al Kilgour.
- KFAB, Lincoln, Nebr. (340.7),** 5:30-6:30 p. m., Buick Little symphony; Belshaw's orchestra; 8:30-10:30, Beatrice quartet; Earl Watson, tenor; Belshaw's orchestra; Ralph Hall, ukulele soloist; Waikiki trio.
- KFMF, Northfield, Minn. (337),** 9-10 p. m., musicale.
- KFNF, Shenandoah, Iowa (266),** 7 p. m., concert, Henry Field Seed company.
- KFVE, University City, Mo. (240),** 10 p. m., Paul and Jack Snyder, Radio entertainers, Orchestra Romana.
- KMA, Shenandoah, Iowa (252),** 6:45 p. m., domestic science timely topics, Le Ona Teget, June E. Case; 9-11, Farnham trio.
- KPRC, Houston, Texas (296.9),** 7:30 p. m., Blandhard's dance orchestra; 8:30, Mrs. Robert B. Collier, lyric soprano; 9, Eddie Synopators; 10, Frank Tilton, pianist.
- KSD, St. Louis, Mo. (545.1),** 7 p. m., Rader's orchestra.
- KTHS, Hot Springs National Park, Ark. (374.8),** 9-9:20 p. m., concert, Meyer-Davis orchestra, Lon Chassy, director; 9:20-9:30, contralto solos, Mrs. Byrd Riggsby; 9:30-9:45, New Arlington string trio; 9:45-10:15, dance concert.
- KYW, Chicago, Ill. (535.4),** 6:35-7 p. m., bedtime story, Uncle Bob; 7-7:30, dinner concert, Congress hotel; 7:33, "Entertaining Plans," Vivette Gorman;

- 7:45, "Safety First"; 8-9, musical program; 10-12:30, revue; Coon-Sanders Original Nighthawks; organ recital, Albert May Malotte.
- WAMD, Minneapolis, Minn. (243.8),** 7 p. m., Garrick theater symphony orchestra; 7:30, Jack Melerick, organist; 8, Marion Kearman, violinist; Harold Janesky, tenor; 10:30, Edissson Rondeau.
- WBEM, Chicago, Ill. (226),** 6-10 p. m., Samovar orchestra; Fair and Warner duo; Torrid duo; Blue Deuces; George Marbach, tenor; 10-12, Montmartre orchestra; Bert Davis, clown of the air; Bernard Gamson, violinist; Corrine Jordan and Vera Gilbert; Devon Comedy four; Honky-Tonk Gloom Chasers; Joseph Raieff, pianist; Leona Hayes, harpist.
- WCCO, Minneapolis-St. Paul, Minn. (416.4),** 6 p. m., Edison Day program, talks, R. F. Pack, E. W. Decker; 7, midweek church service, Rev. R. H. Newton; 8, program from WFAF, Points of Progress, Ipana Troubadours; 10:05, Golden Pheasant orchestra; 11:30, Eddie Dunstetter, organist.
- WDAF, Kansas City, Mo. (365.6),** 6-7 p. m., address, speaker, Health Conservation association; address, Ralph E. Herrick; Tell-Me-a-Story lady; Trianon ensemble; 8-9:15, classical music, Star's Radio string orchestra; 11:45-11, Merry Old Chief; Eddie Kuhn's Kansas City Athletic club orchestra; Earl Coleman's orchestra.
- WEBB, Chicago, Ill. (370.2),** 7-8 p. m., Oriole orchestra; Florence Behrend, soprano; 9-10, Oriole orchestra; Correll and Gosden; Robert York, tenor; 11-1, Oriole orchestra; Correll and Gosden; Robert York, tenor; Oriole orchestra.
- WENR, Chicago, Ill. (266),** 6-7 p. m., Rauland lyric trio; 8-10, All-American Pioneers; J. E. Peterson, bass; John Papa, concertina soloist; Archie Rawls, tenor; Floyd Falch, Vincent Vallee, tenor; 12-2, All-American Pioneers.
- WGES, Oak Park, Ill. (250),** 7-9 p. m., Richard Dale, baritone; Louise Wyse, soprano; John MacFarlane, bass; John Stamford, tenor; 11-2 a. m., Kampus Collegians orchestra; Rose Sweeney, soprano; Frank Gallery, tenor; Lew Russell, Sue Olmstead, ukulele soloist; DeWitt & Owen; Evans Lloyd, baritone.
- WGN, Chicago, Ill. (370.2),** 6:30-7:30 p. m., Drake concert ensemble, Blackstone string quartet; 8-9, WGN string trio; 10-11, jazz scamper, Jack Chapman's and Blackstone orchestra.
- WHAD, Milwaukee, Wis. (278),** 6-7 p. m., Arthur Richter, organist; 8-10, Wisconsin Roof garden orchestra.
- WHAS, Louisville, Ky. (399.8),** 7:30-9 p. m., Barney Rapp's orchestra.
- WHB, Kansas City, Mo. (365.6),** 7-8 p. m., musical program; automotive talk, John Burns.
- WHO, Des Moines, Iowa (526),** 6:30-7:30 p. m., Reese-Hughes orchestra; 7:30-9, Harry Armigido, banjoist; Sam Caplan, violinist; Jim Blacksmith, harmonica soloist; "Old King Cole" and Leonard Kirkwood, harmony singers; Cornelius Ahern, baritone; 9-10, Corn Sugar orchestra; 10-12, dance program.
- WKRC, Cincinnati, Ohio (422.3),** 8 p. m., book review, Alice B. Coy; 8:15, Marion McKay and his orchestra; 8:45, popular studio features; 9:15, Marion McKay and his orchestra.
- WLS, Chicago, Ill. (344.5),** 6:30 p. m., Ralph Emerson, organist; 7, lullaby time; 7:15, WLS trio; 7:45, Ruth Olt, soprano; 8, Post's corner, Wallace Bruce Amsbary; 8:15, syncopation hour, Ideal quartet; 9, Abe Lyman's College Inn orchestra; 9:10, Better Music hour, Clemens A. Hutter; 10, Abe Lyman's College Inn orchestra; 10:10, Westminster quartet; 11, Ralph Emerson, organist.
- WLW, Cincinnati, Ohio (422.3),** 12:15 p. m., Irene Downing and Marjory Hebestreit, organ and piano duets; 4, "Shut-in Program"; 7, Hotel Gibson orchestra, Robert Visconti, director; 10, "Pop" concert, Phi Delta Theta of University of Cincinnati; 10:30, Tridyn orchestra; 11:15, Johanna Grosse, organist.
- WMAQ, Chicago, Ill. (447.5),** 6 p. m., Chicago theater organ recital; 6:30, Georgene Faulkner, the story lady; 8, Northwestern university lecture; 8:30, General Electric night program; 9, WMAQ players.
- WMBB, Chicago, Ill. (250),** 7-8 p. m., Trianon duo, Beatrice Teller; J. Bodewalt Lampe, director; 9-11, Woodlawn theater orchestra, Armin Hand, conductor; Marquette banjo four, popular program.

- WOC, Davenport, Iowa (483.6),** 9-10 p. m., Ipana Troubadours; 10-11, Erwin Swindell, organist; Grace Huber-Lohmiller, soprano.
- WOK, Chicago, Ill. (217.3),** 10-11 p. m., Ned Miller, tenor; Herman Sznauko, violinist; Harriet Lee, contralto; Rita McFawn, soprano; Cy Berg, ukulele soloist; Banks Kennedy, organist; Harold Morava, tenor; LeRoy North, pianist.
- WORD, Batavia, Ill. (275),** 8 p. m., Webster hotel concert trio; 8:15, I. B. S. A. choral singers; 8:30, address, Calvin H. Swinge.
- WOS, Jefferson City, Mo. (440.9),** 8 p. m., address, George Pickens; musical program, Mrs. W. W. Bratton.
- WQJ, Chicago, Ill. (447.5),** 7-8 p. m., dinner concert, Ralph Williams and his Rainbo Garden orchestra; program, Van Higgins family; 10-1 a. m., Ralph Williams and his Skylarks; Melodians, Esther Trostred, mezzo-soprano; Fontella trio; Fred A. Jacobson, monologist; Tillie Miller, contralto; Clarence Theders, tenor; J. Edwin Peterson, basso; Sandy Meek, Scotch tenor; Harry Sosnick, pianist, and artists; 1-2, Ginger hour.
- WSA, Cincinnati, Ohio (325.9),** 7-8 p. m., Edison hour of music; 8, WFAF Waterman Pen program; 9, WFAF Ipana Troubadours; 10, Congress Playing Card string quartet.
- WSUI, Iowa City, Iowa (483.6),** 7:45 p. m., college of the air, Carpenter, Porter Ruckmick.

Mountain Time Stations

- KFWA, Ogden, Utah (261),** 9-10 p. m., program, Globe Mills; 10-11, musical program, Lion Coal company, Ellis Fuel company; 11-12, Olie Reeves and his orchestra.
- KOA, Denver, Colo. (322.4),** 6:30 p. m., Herbert White and his Silver State orchestra; 8, scientific football, Tom McVamara; 8:10, Edison Day, White and his Public Service company saxophone band; "Electricity on the Farm," Clare N. Stannard; Olinger male quartet; "Civilization and Electricity," Howard S. Robertson; Stewart A. Housman, reader; KOA orchestra.

Pacific Time Stations

- KFOA, Seattle, Wash. (454.3),** 6:45-8:15 p. m., Hopper Kelly company; 8:30-10, Times studio program.
- KFPG, Hollywood, Calif. (238),** 5-6 p. m., home hour with Georgia Simmons and the neighborhood children; 8-9, Maggie O'Shea, the blarney girl, and her entertainers in an hour of ballads; 9-10, KFPG concert orchestra, arranged by C. Harold Ramey.
- KFWB, Hollywood, Calif. (252),** 6-7 p. m., children's hour, Big Brother of KFWB; 7-7:30, Mutual Motors hotel dance orchestra; 7:30, microphone brevities; 8-9, Warner Brothers' syncopators, Barbara Bunnell, blues singer; LeRoy Kulberg and his ukulele; 9-10, Kathryn Martin, soprano; Frank Pierce and Vic Beall, popular songs; Rogers' Hawaiian trio; 10-11, Warner brothers' frolic, direction Norman Manning.
- KGO, Oakland, Calif. (361),** 6-7 p. m., dinner concert, Sherman, Clay and company; 8, Arion trio; Wigginton E. Creed, president.
- KGW, Portland, Ore. (491.5),** 8-10 p. m., electric night, Edison's birthday; 10-11, Sherman, Clay and company.
- KHJ, Los Angeles, Calif. (405.2),** 5:30-6:30 p. m., Leighton's Arcade cafeteria orchestra, Jack Cronshaw, leader; 6:30-7:30, history story, Prof. Walter Sylvester Hertzog, Dick Winslow, juvenile reporter; Mickey McBan, screen starlet; Helen Lem, singer; 8, Dr. Mars Baungard, scientific lecturer; 8:30-10:30, program, F. B. Miller Hudson-Essex dealer, arranged by J. Howard Johnson; 10:30-11:30, Art Hickman's Billmore hotel dance orchestra; Frank Ellis, leader.
- KNX, Hollywood, Calif. (336.9),** 5:30-6:15 p. m., Wur-litzer pipe organ studio, Town Tattler; 6:15, travel talk, W. F. Alder; 6:30-7, Atwater Kent Radio orchestra, Paul Finstein, leader; 7-8, Ambassador hotel concert orchestra, Josef Rosenfeld, leader; 8-9, program, Security Trust and Savings bank; 9-10, program with a kick, Hercules Gasoline company; 10-11, hour of dance music.
- KPO, San Francisco, Calif. (428.3),** 6:40-7 p. m., Waldemar Lind and the States Restaurant orchestra; 7-7:30, Rudy Selger's Fairmont hotel orchestra; 8-9, Atwater Kent artists; 9-10, Goodrich Silvertown Cord orchestra; 10-11, Waldemar Lind and the States Restaurant orchestra.
- KWSS, Pullman, Wash. (348.6),** 7:30-9 p. m., Cougar Collegians; "Planning a Girl's Room," Gladys Gallup; agricultural talk; book reviews, Alice Lindsay Webb.

Thursday, October 22

- Thursday, silent night for: CHIC, CHNC, CNRA, CNRE, CNRO, CNR, CNRT, CNRV, KFAB, KFAU, KFD, KFMB, KFMC, KFMD, KFMA, KFV, KFVB, KGW, KGB, KOB, KSD, KTL, KWSC, PWX, WAG, WCEE, WEAQ, WEBA, WHAD, WJJD, WLIT, WOR, WOS, WSUI, WTAM.

Eastern Time Stations

- KDKA, Pittsburgh, Pa. (309.1),** 6:15 p. m., dinner concert; 7:45, "Through the Saragossa Sea and the Galapagos Island," Jay F. W. Pearson; 8, "History of Communication," 8:30, "Edward MacDowell," Richard Kountz; KDKA Little symphony orchestra; 9, KDKA Little symphony orchestra; Evan Lloyd quartet; 11:15, midnight concert.
- WBBR, New York, N. Y. (272.6),** 8 p. m., Watchtower instrumental trio; 8:10, Stanley Gohlinghorst, baritone; 8:20, Sunday school lesson; 8:40, Stanley Gohlinghorst, baritone.
- WBZ, Springfield, Mass. (333.1),** 6:30 p. m., Leo Reil-

- man's Hotel Lenox ensemble; 7:05, Max Zides and his ukulele; 7:30, Winston Sharples, pianist; 7:45, to be announced; 8, program, Noyes-Buick company; 9, evening of opera, Madame Vinello-Johnson.
- WCAE, Pittsburgh, Pa. (461.3),** 6:30 p. m., dinner concert, William Penn hotel; 8, Larkin period; 9, Atwater Kent Radio artists; 10, Goodrich Silvertown Cord orchestra.
- WCAU, Philadelphia, Pa. (277.6),** 6:30 p. m., Billy Hayes and his Cathay tea garden orchestra; 7:30, Snellenburg symphony orchestra; 8, Kenneth Carney, Hawaiian guitarist; 8:30, studio feature; 9, Barry O'More, Irish tenor; 9:15, Radio artists; 9:30, Frank Cook, old time songs; 10, Sesqui Centennial hour.
- WCTS, Worcester, Mass. (268),** 8-8:30 p. m., Larkinites; 8:30-9, program from WFAF; 9-10, program; 10-11, Silvertown Cord orchestra.
- WCX, Detroit, Mich. (517),** 6 p. m., dinner concert, Book-Cadillac hotel; 8, musical program.
- WEAF, New York, N. Y. (491.5),** 4-4:15 p. m., Julius Behrendt, baritone; 4:15-4:45, Famous Players orchestra; 4:45-5, talk, Leonard Barron; 6-7, dinner music, Waldorf-Astoria; 7-7:30, services, Greater New York Federation of Churches; 7:30-8, Cushman's serenaders; 8-8:30, "The Larkinites"; 8:30-9, talk, George Elliott Cooley; 9-10, WFAF concert ensemble; 10-11, Silvertown Cord orchestra; 11-12, Vincent Lopez and his orchestra.
- WEAR, Cleveland, Ohio (389.4),** 7 p. m., Mariejo Moore's Melody Maids; 8, RTL program; 9, Chauncey Lee's orchestra; 10, Vincent Percy, organist.
- WEEI, Boston, Mass. (476),** 7:15 p. m., talk, Malcolm E. Nichols; 7:30, Chamber of Commerce organ recital; 8, WEAF; 11, talk, Malcolm E. Nichols.
- WGBS, New York, N. Y. (315.6),** 6-6:30 p. m., Uncle Geebee; 7-8, Voltaire hour of music; 8-8:30, Crystal Palace orchestra; 8:30-9, Footlight and Lamplight, Oliver Saylor; 9:30-10, May Singhi Breon, Peter de Rose and their three Jack Roses.
- WGCP, New York, N. Y. (315.6),** 8-5:30 p. m., musical program.
- WGR, Buffalo, N. Y. (319),** 2:30-4:30 p. m., Buffalo Radio show program, featuring the Erlenbach orchestra; 6:30-7:30, Vincent Lopez Hotel Stalter dance orchestra, Harold Gieser, director; 8-11, jointly with WEAF, including the Larkinites and the Goodrich Silvertown Cord orchestra.
- WGY, Schenectady, N. Y. (379.5),** 2:30 p. m., Stephen E. Boisclair, organist; 6:30, Ten Byck trio; 7:45, Linda Noble, soprano; 8:15, U. S. Army band; 9:30, Royal hour, WJZ; 10:30, Stephen E. Boisclair, organist.
- WHAR, Atlantic City, N. J. (275),** 7:30 p. m., lecture period; 8, Seaside hotel trio; 9, studio concert.
- WHN, New York, N. Y. (361.2),** 3:15-4:30 p. m., Lexington theater orchestra; 7:30-8, Miller, Piotti and Val songs and piano; 7:30-8, Iceland orchestra; 7:30-8, Cecil B. Kennedy's quintet; 8-8:30, Will Oakland's Chateau Shanley; 10-10:30, Caravan club orchestra; 10:30-11, Club Kentucky orchestra; 11-11:30, Swane club orchestra; 11:30-12, Bandbox orchestra and revue; 12-12:30, Ted Lewis and his orchestra.
- WJAR, Providence, R. I. (305.9),** 8 p. m., Larkinites; 8:30, musical program, Donald MacDonald, director and tenor; vocal and instrumental solos, duets; 10, Goodrich Silvertown Cord orchestra.
- WJR, Detroit, Mich. (517),** 7 p. m., studio orchestra, Jean Goldkette, director; 9, Jean Goldkette's serenaders; 10, Jean Goldkette's Victor Recording orchestra.
- WKAQ, San Juan, P. R. (340.7),** 7:30-9 p. m., music, La Cafeteria.
- WLIT, Philadelphia, Pa. (394.5),** 2:30 p. m., Edna Wyatt Webster, soprano; 7:30, Dream Daddy's bedtime stories.
- WMCA, New York, N. Y. (340.7),** 6-6:30 p. m., Olcott Vail; 6:30-6:45, Lulu Quinn Weyant, uke; songs; 7-7:30, Sunnyside orchestra; 7:30-8, Larson's orchestra; 8:30-9, Snedden Weir, baritone; 9-9:15, Uke Bob McDonald; 10-10:45, Twelfth Street band; 11-12, Ernie Golden and his Hotel McAlbin orchestra.
- WNYC, New York, N. Y. (526),** 7-7:10 p. m., market high spots; 7:10-7:30, Club Arcady orchestra; 7:30-7:35, police alarms; 7:35-8, Club Arcady orchestra; 8-10, studio program; 10-10:30, talk, Dr. Sydney N. Usher; 10:30-10:35, police alarms and weather forecast; 10:30-11:30, orchestra.
- WOO, Philadelphia, Pa. (508.2),** 7:30 p. m., Adelphia Roof Garden orchestra.
- WOR, Newark, N. J. (405.2),** 6:15-6:17 p. m., "Words Often Mispronounced"; 6:17-6:30, sports talk, Bill Wathey; 6:30-7:15, Hotel Shelton ensemble.
- WPG, Atlantic City, N. J. (299.8),** 6:30 p. m., sports, Billy Rocap; 6:45, Arthur Scott Brook, organist; 7, Hotel Ambassador dinner music; 8, world-wide excursions, Alfred James P. McClure; 8:15, studio program; 9, Hotel Traymore concert orchestra; 10:30, Silver Slipper.
- WRC, Washington, D. C. (469),** 7 p. m., Shoreham hotel orchestra; 8, Smithsonian talk; 8:15, concert, U. S. Army band, William Starnal, leader, WJZ; 9:15, announced; 9:30, WJZ Royal hour; 10:30, Meyer Davis LeParadis roof band.
- WTIC, Hartford, Conn. (475.9),** 6:30 p. m., dinner music, Hub Restaurant trio; 7:30, "Fall and Winter Motor Travel," Hon. R. B. Stoeckel; 7:45, dinner music.
- WWJ, Detroit, Mich. (352.7),** 6 p. m., dinner concert; 8, concert from WEAF.

Central Time Stations

- KFNF, Shenandoah, Iowa (266),** 7 p. m., Bohemian band, E. L. Dorland, director.
- KLDS, Independence, Mo. (441),** 8 p. m., Annual Independence Chamber of Commerce banquet, speakers, Colvin Brown, Walter B. Weisenberger; Independence (Continued on page 12)

J. OF MINNESOTA "PEP" FEST AT WAMD



WHAS, Louisville, Ky. (399.8), 7:30-9 p. m., concert, Louisville Music and Radio company; Gene Klingman, director; Sara King, pianist.

WHB, Kansas City, Mo. (365.6), 7-8 p. m., Sweeney orchestra.

WHO, Des Moines, Iowa (526), 7:30-9 p. m., program, Palo Alto Grange orchestra; 11-12, dance program.

WLS, Chicago, Ill. (344.6), 8:30 p. m., Ralph Emerson, organist; 7, lullaby time; 7:15, "Southern Songs," Rex Maupin, director; 7:45, Ruth Olt, soprano; 8, R. F. D. program; Evans Brothers' quartet; 9, Abe Lyman's College Inn orchestra; 9:10, Rodeheaver hour, Vivian Tripp, director; 10, College Inn orchestra; 10:10, Alice LaTarte, pianist; 10:25, Evans Brothers' quartet.

WMAQ, Chicago, Ill. (447.5), 6 p. m., Chicago theater organ; 6:30, Family Altar league; 6:30, Wide-Awake club program; 8, musical lecture, Mr. and Mrs. Marx E. Obendorfer; 8:30, Whitney trio; 9, U. of Chicago lecture; 9:20, Elizabeth Stokes, soprano.

WMBB, Chicago, Ill. (250), 7-8 p. m., Trianon duo, J. Bodewalt Lampe, Beatrice Teller, Florence Rush, Joel Lay, Jean St. Anne; 9-11, Trianon orchestra, Dell Lampe, conductor; Edward Hines, Morey Alsawang, Jack Murnane, Cecil and Esther Ward, Stokes and Agne.

WMC, Memphis, Tenn. (499.7), 8:30 p. m., Atwater Kent Radio company; 11, midnight frolic.

WOAW, Omaha, Neb. (526), 6 p. m., music review, Hester Bronson Copper; 6:40, Gilbert Jaffy and his little symphony; 7:10, sport talk, Ivan L. Gaddis; 9, DeLuxe program.

WOC, Davenport, Iowa (483.6), 8-10 p. m., musical program, Schmidt Music House concert orchestra.

WOK, Chicago, Ill. (217.3), 10-11 p. m., Harry Davis, tenor; Herman Sinaiko, violinist; Harriet Lee, contralto; Haymakers trio; Berger Wedberg, tenor; Arnold B. Stephenson, musical saw soloist; Rosemary Hughes, soprano; Ed Kemp, tenor; Banks Kennedy, organist; LeRoy North, pianist.

WORD, Batavia, Ill. (275), 8 p. m., Webster hotel concert trio; 8:15, WORD Radio study club; 8:30, I. B. S. A. orchestra.

WOS, Jefferson City, Mo. (440.9), 8 p. m., "The How and Why of Radio Market News," Homer L. Gobble; musical program, Helen Tolson.

WQJ, Chicago, Ill. (447.5), 7-8 p. m., Ralph Williams and his Rainbo Gardens orchestra; Everett G. Mitchell, baritone; Blanche Robinson, pianist; Maryl Larson, soprano; 10-1, Ralph Williams and his Rainbo Sky-larks; West brothers, Hawaiian guitarists; H. Lucille Long, harmonica player; Parrish and Ward, harmony singers; Larry Shay; Keithley and Kauffer, singing



and playing; Electa Kind, soprano; Ed McGinnis, piano-accompanist; Lean Terrill, baritone; 1-2, Ginger hano.

Mountain Time Stations

CNRE, Edmonton, Can. (516.9), 8:30-10:30 p. m., studio concert, Mrs. Hale, director, mandolin, guitar and banjo orchestras.

KFAU, Boise, Idaho (278), 8 p. m., recital, Mrs. Leslie Long, director.

KFWA, Oden, Utah (261), 9-10 p. m., studio program.

KOA, Denver, Colo. (322.4), 6:30 p. m., Herbert White and his Silver State orchestra; 7:30, Sunday school lesson; 8, scientific football, Tom McNamara; 8:10, dramatic features, Denver Community players; "The Man in the Stalls," "The Wonder Hat," "Her Tongue."

Pacific Time Stations

CNRV, Vancouver, Can. (291), 8 p. m., "Big Game Hunting in Canada," H. E. Melanson; 8:30, Sidney G. Horton, baritone; Dorothy Notzel, pianist; Betty Newton, violinist; Belmont Cabaret orchestra.

KFOA, Seattle, Wash. (454.3), 6:45-8:15 p. m., Sherman, Clay and company studio program; 8:30-10, "Times studio program; 10-11:30, Eddie Harkness and his orchestra.

KFPG, Hollywood, Calif. (238), 5-6 p. m., home hour, Georgia Starnes and neighborhood children; 8-9, KFPG concert hour; 9-11, Freeman Lang and his playmates, a frolic.

KFWB, Hollywood, Calif. (252), 7:30 p. m., microphone briefs; 8-9, California serenaders' dance orchestra, George Cronk, leader; Ray Kellogg and Bill Haleb, the jazz twins; 9-10, program, Paralta Photographic studios, Paralta orchestra, Drove Norton Lindsay, baritone; 10-11, Warner brothers' frolic, direction Charlie Wellman.

KGO, Oakland, Calif. (361), 6-7 p. m., dinner concert, Sherman, Clay and company.

KGW, Portland, Ore. (491.5), 9-10:30 p. m., Sherman Clay and company; 10:30-12, Hoot Owls; Rose City trio, Pantages acts.

KHJ, Los Angeles, Calif. (405.2), 5:30-6:30 p. m., Leighton's Arcade cafeteria orchestra, Jack Cronshaw, leader; 6:30-7:30, history story, Prof. Walter Sylvester Herzog, Simon Waronker, 10-year-old violinist; Bettlemac Pfefferkorn, readings; Mickey DeLano, pianist; 8-10, program, Western Auto Supply company, arranged by J. Howard Johnson in memoriam to father of Joseph Heindle, concert cellist; 10-11, Art Hickman's Billmore hotel dance orchestra, Frank Ellis leader.

Central Time Stations

Saturday, October 17: 6, KFAB, WENR, WMAQ, WOAW, WOK; 6:15, WCCO; 6:30, WGN; 7, KOIL, KSD, KYW, WGN, WMBB, WQJ; 7:30, WEBB, WHAS; 8, KFNF, KPRC, KYW; 8:15, WCCO; 8:30, KYW, KPRC, WFAA, WHAS, WMC; 9, WKRC, WMAQ, WOAW, WOC; 9:15, KPRC; 9:30, WOC.

Sunday, October 18: 6:30, KLDS, WHT; 6:45, WORD; 7, KYW, WLS, WORD; 7:30, WHO; 8, KFDM, KPRC, WCB, WFAA, WGN, WQJ; 8:30, WLW; 9, WQJ; 9:10, KTHS; 9:15,

Index to Classical Concerts

TABULATED below is a time table of the stations giving classical concerts this week. Stations are divided into the four different standard times in use. The hours are given in the kind of time in use at each listed station. By using this table as an index and referring to the complete programs below, full information will be obtained.

Classical

Eastern Time Stations

Saturday, October 17: 6, WCX, WFAF, WMCA, WRBO; 6:17, WOR; 6:30, WCAE; 7, WEAR, WNYC; WRC; 7:15, WFAF; 7:35, WFAF; 8, WBBR, WNYC; 8:15, WRC; 8:30, WCAE; 8:40, WBBR; 9:30, WFAF; 10, WFAF.

Sunday, October 18: 6, WCAU; 6:30, WCAE, WOR; 7, WEAR; 7:20, WCAE, WCTS, WFAF, WEEI, WWJ; 8, WBZ, WEAR, WGBS, WGCP, WKAQ; 8:30, KDKA, WBZ, WGCP; 9, WBZ, WEAR, WGY, WHAR, WNYC; 9:15, WCAE, WCTS, WFAF, WEEI; 9:20, WNYC; 9:45, WCTS, WGCP; 10, WNYC; 11, WHN; 11:15, WHAR.

Monday, October 19: 6, WCX, WFAF, WMCA, WRBO, WWJ; 6:05, WIP; 6:30, CFCA, WBZ, WCAE, WGY, WTIC; 7, WEAR, WEBJ, WJR, WOO; 7:15, WFAF; 7:30, WEEI, WGY, WMCA; 8, WBBR, WBZ, WCAU, WCX, WHAR, WTIC; 8:15, WBZ, WHAZ, WNYC; 8:30, CHNC, KDKA, WBBR, WBZ, WGCP; 8:45, WFAF, WOO; 8:55, WBBR; 9, WBZ, WCAE, WEEI; 9:10, WLIT; 9:15, WGCP; 9:30, WBZ; 10, CHNC, WFAF, WOO; 10:10, WEEI; 10:15, WOO; 10:30, KDKA; 10:40, WEEI; 11, WHN.

Tuesday, October 20: 6, WBZ, WCX, WFAF, WMCA, WRBO, WWJ; 6:05, WIP; 6:17, WOR; 6:30, WCAE, WGY, WTIC; 7, WEAR, WEBJ, WGBS, WJR, WOR, WTIC, WWJ; 7:20, WTIC; 7:30, WCAU, WFAF, WOO; 7:45, WEBJ; 8, WBZ, WCAE, WCAU, WCX, WEAR, WEEI, WGR, WHAR, WRC, WTIC; 8:05, WNYC; 8:15, WEBJ; 8:30, KDKA, WBZ, WCAE, WCTS, WFAF, WEEI, WFI, WGR; 9, WCAE, WCTS, WFAF, WEEI, WFI, WGR; 9:15, WREO; 9:30, WBZ, WHN, WRC, WTIC; 10, WCAE, WCTS, WFAF, WEAR, WEEI, WFI, WMCA; 10:30, WGR; 11:15, WHAR.

Wednesday, October 21: 6, WCX, WFAF, WMCA, WRBO, WWJ; 6:05, WIP; 6:30, WBZ, WCAE, WTIC; 6:45, WGY; 7, WEAR, WJR; 7:20, WTIC; 7:30, WFAF, WEEI, WOO; 8, WBZ, WCTS, WCX, WFAF, WEEI, WKAQ, WMCA, WWJ; 8:05, WNYC; 8:15, WCAU, WOR; 8:30, KDKA, WBZ, WCAE, WFAF, WOO, WOR; 8:45, WBZ, WCAU, WEAR, WEBJ, WFI, WGR, WHAR, WNYC, WRC; 9:30, WREO; 10, WCAE, WCAU, WCTS, WFAF, WEAR, WEEI, WGR, WGY; 10:15, KDKA; 11:30, WGY.

Thursday, October 22: 6, WBZ, WCX, WFAF, WMCA, WRBO, WWJ; 6:05, WIP; 6:17, WOR; 6:30, WCAE, WGBS, WGY, WOR, WTIC; 7, WFAF, WEAR, WGBS, WJR, WWO; 7:15, WFAF; 7:30, WEEI, WCAU, WWO; 7:45, WEBJ; 8, WBZ, WCAE, WCAU, WCX, WEAR, WEEI, WGR, WHAR, WRC, WTIC; 8:05, WNYC; 8:15, WEBJ; 8:30, KDKA, WBZ, WCAE, WCTS, WFAF, WEEI, WFI, WGR; 9, WCAE, WCTS, WFAF, WEEI, WFI, WGR; 9:15, WREO; 9:30, WBZ, WHN, WRC, WTIC; 10, WCAE, WCTS, WFAF, WEAR, WEEI, WFI, WMCA; 10:30, WGR; 11:15, WHAR.

Friday, October 23: 6, WHAD, WMAQ, WOAW, WOK; 6:30, WGN; 7, KYW, WHT, WLS, WLW, WMBB, WOAW, WQJ; 7:30, KFNF, KOIL, WHAD, WHO, WSAI; 8, KLDS, WBAP, WCB, WCCO, WOC, WORD, WSAI, WSB; 8:20, KYW, WMAQ; 8:30, KPRC, WFAA, WGN, WHAD, WMC, WOAI; 8:35, WMAQ; 9, KPRC, KTHS, KYW, WCCO, WHAD, WOAW, WOC, WSAI; 9:10, KTHS; 9:30, WPX; 9:45, KTHS; 10, KMA, KTHS, WLS, WLW, WOC, WSAI; 10:10, WSAI; 10:30, WLW; 11, WHAD, WLW; 11:30, WCCO, WLW; 11:45, WLW.

Saturday, October 17: 6, KFOA, KHJ; 6:30, KNX; 6:45, KFOA; 7, KNX; 7:30, KNX; 8:10, KGO; 8:15, KHJ.

Sunday, October 18: 6:30, KHJ; 6:35, KPO; 7, KHJ, KNX; 8, KHJ, KNX, KPO; 9, KHJ, KNX; 10, KNX.

Monday, October 19: 6, KFOA, KGO; 6:30, KNX; 6:45, KFOA; 7, KPO; 7:30, KNX; 8, KGW, KHJ; 9, KGW; 10, KHJ.

Tuesday, October 20: 6, KFOA, KGO, KHJ; 6:30, KNX; 6:45, KFOA; 7, KNX; 8, KGO, KHJ; 8:30, KFOA; 9, KGW, KPO.

Wednesday, October 21: 6, KFOA, KGO, KHJ; 6:30, KNX; 6:45, KFOA; 7, KNX; 8, KGW, KHJ; 9, KGW, KPO.

Thursday, October 22: 6, KFOA, KGO, KHJ; 6:30, KNX; 6:45, KFOA; 7, KNX; 8, KGW, KHJ; 9, KGW, KPO.

Friday, October 23: 6, KFOA, KGO, KHJ; 6:15, KPO; 6:45, KFOA; 7:30, KFAB, KNX; 8, KHJ, KNX, KPO; 8:30, KFAB; 9, KPO.

DANCING

Central Standard Time

Saturday, October 17: 8, Kgw, Wgy, Wmbb, Wpg, Wtas; 8:05, Wip; 8:30, Webh, Wgy, Wsmb; 9, Wfa, Wmbf, Wmca, Wgi, Wre, Wreo, Wtas; 9:30, Wcee, Wges, Wgn, Wjld, Wrc; 10, Kpo, Kths, Wwhg, Wwo; 10:30, Wkrc, Wmbf, Wreo, Wpg; 10:30, Webh, Wges; 11, Kfwb, Koa, Wwhg, Wcee, Wfaa, Wjld, Wdfr, Woc; 11:15, Wdad; 11:30, Wges; 11:45, Wdad; 12, Kgo, Kgw, Khj, Knx.

Monday, October 19: 8, Wkrc, Wmbb, Wtas; 8:30, Wfa, Wsmb; 8:45, Wrc; 9, Wcee, Wgr, Wmbf, Wtas; 9:05, Wwhg; 9:25, Kths; 9:30, Wges, Wjld; 10, Kpo, Wgr, Wwhg, Wmbf, Wwo; Wtam; 10:30, Wcee, Wjld; 11, Who, Wkrc; 11:30, Wjld; 11:45, Wdad.

Tuesday, October 20: 8, Wmbb, Wtas; 8:30, Wcau, Wwebb, Wip; 9, Wcx, Wfa, Wmaq, Wmbf, Wmc, Ww; 9:05, Wwhg; 9:15, Wwhg; 9:30, Wwhg; 9:45, Wwhg; 10, Wwhg; 10:30, Wwhg; 10:45, Wwhg; 11:30, Wjld; 11:45, Wdad.

Wednesday, October 21: 8, Kgw, Whad, Whn, Wkrc, Wmbb, Wtas; 8:30, Kgw, Wcau, Wwebb, Wwhg, Wwhg; 9:30, Wwhg; 9:45, Wwhg; 10, Wwhg; 10:30, Wwhg; 10:45, Wwhg; 11:30, Wjld; 11:45, Wdad; 12, Khj, Knx, Woi, Wqd.

Thursday, October 22: 8, Wfa, Wip, Wjar, Wmbb, Wrc, Wtas; 8:30, Wcau, Wwebb, Wmaq, Wsmb; 9, Wfa, Wip, Wmbf, Wmca, Wwd, Wre, Wtas; 9:25, Kths; 9:30, Wgn, Woi, Wsmb; 10, Wmbf; 10:30, Webh; 11, Kfwb, Wfaa, Who, Woc; 12, Kgo, Kgw, Khj, Knx, Kpo, Wqd.

Friday, October 23: 8, Kgw, Wcau, Wfaa, Wfa, Wmbb, Wtas; 8:30, Kgw, Wcau, Wwebb, Wwhg, Wtas; 9:25, Kths; 9:30, Wgn, Woi, Wsmb; 10, Wmbf; 10:30, Webh; 11, Kfwb, Wfaa, Who, Woc; 12, Kgo, Kgw, Khj, Knx, Kpo, Wqd.

central Atlantic City high school; 8:15, studio program; 9, Hotel Ambassador concert orchestra; 10:30, Silver Slipper.

WRC, Washington, D. C. (469), 5 p. m., WRC's foolish entertainers; George F. Ross and Ellsworth Tompkins; 6, book reviews.

WTIC, Hartford, Conn. (475.9), 6:30 p. m., Young People's half hour; 7, dinner music, Emil Heimberger's Hotel Bond trio; 7:30, dinner music; 8:30, Travelers Ladies' quartet; Sylvia L. Richard, pianist; Mary Zoller, Erlau H. Wilcox, xylophonists; 10:05, Hotel Bond orchestra; 11:30, popular period; Mary Zoller, xylophonist; Ed. F. Mahoney, tenor; Helen I. Dischert, ukulele soloist.

WWI, Detroit, Mich. (352.7), 6 p. m., dinner concert; 8, News orchestra; 9, dance program.

Central Time Stations

KFAB, Lincoln, Neb. (340.7), 5:30-6:30 p. m., Buick Little symphony; Belshaw's orchestra; 8:30-10:30, Utica band.

KFAX, Northfield, Minn. (337), 10-11 p. m., organ recital.

KFNF, Shenandoah, Iowa (266), 7 p. m., Sunday school lesson; 7:30, concert, Widney sisters.

KFVE, University City, Mo. (240), 10 p. m., Olin Gibson and Henry Miller, entertainers; Orchestra Romaine.

KMA, Shenandoah, Iowa (252), 9-11 p. m., musicale, May Seed and Nursery company.

KSD, St. Louis, Mo. (345.1), 7:30 p. m., "Commerce Hour," John Herget; 8:30, Nolte's dance orchestra.

KTHS, Hot Springs National Park, Ark. (374.8), 9-9:10 p. m., football results; 9:10-10, Meyer-Davis orchestra; Lawson Reid, organist; Meyer-Davis saxophone trio; 10-10:30, Southerners' orchestra.

KYW, Chicago, Ill. (535.4), 6:35-7 p. m., bedtime story, Uncle Bob; 7-7:30, dinner concert, Congress hotel; 7:30-8:30, Home Lovers' hour; 10-12:30, revue; Coon Sanders Original Nighthawks; Albert Hay Malotte, organist.

WAMD, Minneapolis, Minn. (243.8), 6 p. m., George Osborn's orchestra; 7, musical program, Minneapolis public schools; 8, football pep fest; 8:15, Minnesota male quartet; 10:30, Radisson Rondevo.

WBBM, Chicago, Ill. (226), 8-10 p. m., instrumental quartet; Leona Hayes, harpist; Devon Comedy four; Lew Russell; Pete Kules; Montmartre orchestra.

WCCO, Minneapolis-St. Paul, Minn. (416.4), 6:10 p. m., Biley's St. Paul hotel orchestra; 7:30, Minneapolis Community fund talk; farm lecture, dairy farming, lesson 1; 8, musicale; 10:05, Arnold Frank's St. Paul hotel orchestra.

WDAF, Kansas City, Mo. (365.6), 6-7 p. m., address; Tell-Me-a-Story lady; Trianon ensemble; 8-9:30, Star's Radio orchestra; 11:45-1, Merry Old Chief, Plantation players; Earl Coleman's orchestra; Eddie Kuhn's Kansas City Athletic club orchestra; Earl Coleman's orchestra.

WEBB, Chicago, Ill. (370.2), 7-8 p. m., Oriole orchestra; Uptown theater; 9-10, Oriole orchestra; Katherine Forbes, soprano; Beulah Landon, violinist; 10-11 a. m., Oriole orchestra; stories, Wayne Myers; Paul Small.

WENR, Chicago, Ill. (266), 6-7 p. m., Rauland lyric trio; Russell Hendricks, cellist; Marie Tulley; 8-10, Frank Westphal and his All-American Pioneers; Grace Hegseth; Floyd Patch; 12-2, midnight frolic.

WFAA, Dallas, Texas (475.9), 6:30-7:30 p. m., Hauluca School of Hawaiian Music; 8:30-9:30, Daisy Polk, soprano; Mrs. Juanita Blair Price, pianist.

WGES, Oak Park, Ill. (250), 7-9 p. m., John Rankel, baritone; Ruth Kathoff, soprano; Emma Butler, contralto; Gladys Welze, violinist; John Stamford, tenor; 6:45-7, lecture, E. L. Richards; 11-2 a. m., Novelty Broadcasters' orchestra; Marie Wright, Evans Lloyd, Coyne Banjo trio; Kenneth Nelson.

WGN, Chicago, Ill. (370.2), 6:30-7:30 p. m., Drake concert ensemble, Blackstone string quintet; 8-9, WGN string trio; 10-11, jazz scamper program, Jack Chapman's and Blackstone dance orchestras.

WHAD, Milwaukee, Wis. (278), 6-7 p. m., Arthur Richter, organist; 7:05, Bill Juhre's Radio Cartoon game; 8:30-10, Wisconsin theater revue.

STATIONS IN ORDER OF WAVE LENGTHS USED

Table listing radio stations with columns for Meters Call, Call, and Meters Call. Includes stations like KTAB, WJAS, WGBS, etc.

AN EVENING AT HOME WITH THE LISTENER IN CENTRAL TIME

Large table showing radio station schedules for Saturday, Sunday, Monday, Tuesday, Wednesday, Thursday, and Friday. Columns include Call, Location, Met., and broadcast times.

WORLD COURT TALK NEW WLIT FEATURE

“CRIME PSYCHOLOGY” ALSO EDUCATIONAL SUBJECT

Philly Station Maps Out Several Big Educational Projects for Coming Radio Season

PHILADELPHIA.—Station WLIT, one of this city's five big broadcasting stations, has completed arrangements for the broadcasting of a number of big educational features during the coming winter.

Then, there will be a series of lectures on the "Psychology of Crime," conducted by Robert Edwin Pride, author, who has spent a number of years investigating various prisons and penitentiaries.

Current Events and Forum Dr. George Earl Raiguel, lecturer at Columbia university, will continue his series of talk on "Current Events."

The Sunday evening forum will again come into being with the beginning of the winter season. These meetings, so popular last year, are conducted along the lines of the "round table" idea.

The establishment of a Friendly Aid bureau for people in distress, is another feature, to say nothing of a series of five concerts by the Friends of Chamber Music.

Plan Half Hour Programs to Feature Famous Composers

PITTSBURGH.—"Half hours with famous composers," a weekly program taking up the life story of noted musicians and giving some of their best loved music, is being given over Westinghouse Station KDKA on Thursday evenings at 8:30 eastern time.

Richard Kountz, a Pittsburgh composer, is telling the Radio audience about the life of the different composers taken up in this series, while the KDKA Little Symphony orchestra and vocal soloists are presenting the music.

Install Radio Amplifiers in Italian Senate Building

ROME.—Radio amplifiers have been installed in the Italian senate. The speeches from the government bench will be heard in the anterooms and notices broadcast throughout the building indicating the beginning of each speech with the subject and name of the speaker.

Friday, October 23

(Continued from page 13)

KNX, Hollywood, Calif. (336.9), 5:30-6:15 p. m., Wurlitzer pipe organ studio, Town Tattler; 6:15, travel talk, W. P. Alder; 6:30-7, Atwater Kent Radio orchestra, Paul Finstein, leader; 7-7:30, dinner music; 7:30, program, Eastern Outfitting company; 8-9, West Coast theaters by remote control; 9-10, Order of Optimistic Donuts; 10-11, dance music; 11-12, Ray West's Coconut Grove dance orchestra from Ambassador hotel.

Daggett and Artists Go on Hawaiian Trip

Chose KHJ Entertainers to Accompany Chamber of Commerce

LOS ANGELES.—Another honor has been conferred upon KHJ, Los Angeles times station, "Uncle John" Daggett, veteran studio director of that station, and four musicians who appear regularly there have been selected by the Los Angeles chamber of commerce to accompany them on their annual excursion to the Hawaiian islands.

The lucky ones, in addition to Mr. Daggett, are Mary Newkirk Bower, soprano; Bernice Neal, cellist; Helen Mead Little, flutist, and Carolyn Le Fevre, violinist.

This annual excursion by the world's most energetic chamber of commerce is one of the big events of the southern California fall season. The party set sail on October 10 on the steamship City of Los Angeles which arrives at Honolulu October 16.

During their stay on the beautiful islands the KHJ party will broadcast over KGU, the Honolulu broadcaster heard regularly on the Pacific coast.

WDAF POWER GOES IN 1,000-WATT CLASS TOO

Double Old Strength of Kansas City Star Plant

KANSAS CITY, Mo.—The Kansas City Star has announced the installation of a new and more powerful broadcasting station. The new transmitter now being installed is one thousand watts power, twice the power of the present WDAF set.

The 1,000-watt station will be entirely new. The towers and antenna above the Star building will be the only part of the old equipment to remain. The 500-watt station now used by WDAF has been sold to the Hotel Lassen at Wichita, Kan.

The old transmitter has an enviable record for distance. It was heard five times in London last year. It has also been received in South America, Australia and Alaska.

Something New for Kiddies in CNRW Radio Mystery Bag

WINNIPEG, Canada.—Youthful Radio fans found a new interest in listening to CNRW recently when the first of a series of "Grab Bag Parties" was staged with the cooperation of Aunt Aimee who now presides over the children's half hour which is a feature of every program broadcast from the Canadian national station in the Fort Garry hotel.

The party was limited to children under eight years of age, and was the first of many to be held during the next few months. A telephone call or telegram sent to Station CNRW during the broadcast is all that is necessary in the way of entrance fee, and the initial experiment along this line brought a flood of messages to the studio which kept Aunt Aimee busy for hours distributing prizes to the little fans.

FOLLOWING SPORTS THROUGH MIKE

CARLIN, McNAMEE IN TWIN BROADCASTING

FAMOUS PAIR AT MIKE FOR BIG FOOTBALL GAMES

New Technique Will Enliven Radio Accounts of Exciting Eastern Gridiron Battles

NEW YORK.—The WEAF twin announcers, Phillips Carlin and Graham McNamee, will alternate in broadcasting descriptions on the WEAF schedule of the important intercollegiate football games, employing for the first time in sport announcing a new technique of cooperative observing and announcing.

On Saturday, October 17, Phillips Carlin will be at the microphone at the Yankee stadium to describe the Army-Notre Dame game, while McNamee will work with him in observing the details of the play, which one man cannot possibly see for himself.

WEAF has the unique distinction of having two announcers equally capable of handling a sport assignment and the advantages of having both on the scene are many. In the first place since both are experienced announcers and know what is necessary for a vivid description of the game, the one acting as observer will be able to pick out the essential details much more effectually than the ordinary observer who might be carried away by the excitement of the game or by a feeling of partisanship.

How Two Will Work

Next, since each will see all the games on WEAF's schedule, the familiarity and knowledge of the teams will grow accumulatively with each succeeding game. For example, following the Army-Notre Dame game, Carlin will announce the Yale-Army contest and so will be extremely familiar with the Army line-up.

It is evident that the success of the announcing will be practically dependent on both men. The man at the "mike" will observe the distance gained and the type of the play, while the observer will pick out the name of the man carrying the ball, the opponent who tackles him and the other details necessary for a clear understanding of what is going on.

Football Broadcasts

Saturday, October 17

- Army-Notre Dame, WEAF (491.5), WGR (319), WGY (379.5), WJZ (454.3).
- Chicago-Northwestern, KYW (535.4), WBBM (226), WMAQ (447.5).
- Cincinnati-Otterbien, WSAI (325.9).
- Harvard-Holy Cross, WBZ (333.1).
- Iowa-Illinois, WSUI (483.6).
- Michigan-Wisconsin, WGN (370.2).
- Navy-Princeton, WCAP (468.5).
- New Mexico State College-State Teachers' College, KOB (348.6).
- Ohio State-Chicago, WEAO (293.9).
- Oregon Aggies-Whitman, KGW (491.5).
- Pittsburgh-Gettysburg, KDKA (309.1).
- Rolla-Missouri, WOS (440.9).
- Wabash-Minnesota, WCCO (416.4).
- Washington-Nebraska, KFOA (454.3), KFAB (340.7).

MORE STATIONS LIST GAMES ON SCHEDULES

KOB, KFOA and WSUI Announce Football Broadcasts

Three more stations have announced full schedules of football game broadcasts to be added to the already long list. Indications are that every progressive Radio station located anywhere near schools where the great autumn game is played is endeavoring to tie up with the athletic department in order that the less fortunate followers of the sport may see the games through the eyes of "Mike," the popular sport describer. The latest broadcasters to fall in line are KOB, the station of the New Mexico College of Agriculture; WSUI, whose call stands for the State University of Iowa, and KFOA, the Seattle Times plant.

Followers of the gridiron games via air will be exceedingly fortunate if they have receivers that will pick up KFOA in the daytime, because that station will broadcast the games of the University of Washington team. This organization has been making quite a name for itself during the past few years and the 1925

schedule includes every important eleven on the western slope.

The schedules of the three stations mentioned above follow:

- New Mexico, KOB (348.6)**
Oct. 17, New Mexico Aggies-New Mexico State Teachers college.
Oct. 24, New Mexico Aggies-Sul Ross college.
Nov. 14, New Mexico Aggies-Junior college, El Paso.
Nov. 26, New Mexico Aggies-New Mexico Military institute.
- Iowa State, WSUI (483.6)**
Oct. 17, Iowa-Illinois.
Oct. 31, Iowa-Wabash.
Nov. 1, Iowa-Wisconsin.
- Washington, KFOA (454.3)**
Oct. 17, Washington-U. of Nebraska.
Oct. 24, Washington-Whitman.
Oct. 31, Washington-Washington State.
Nov. 7, Washington-Stanford U.
Nov. 14, Washington-U. of California.
Nov. 26, Washington-U. of Oregon.

Announcer Gets Autograph of Author for His Reading

NEW YORK.—The world is small and with the modern means of Radio communication it is getting smaller day by day.

Announcer John B. Daniel is conducting a series of readings for the benefit of the blind and invalid of the Radio audience from Station WJZ here. On the morning following one of his recent readings, he found in his mail a very pleasant letter from the author of the story which he had read the afternoon before. The author thanked him for the splendid manner in which he had handled the reading and notified Daniel that he would receive an autographed copy of the story in the near future.

Seattle Has Interference Trouble

SEATTLE, Wash.—Difficulty is experienced by Seattle fans in eliminating the two local stations, KTCL and KJR, when attempting to get KGO, Oakland, Calif. There is also difficulty noticed in cutting out KFOA, Seattle, when searching the air for KPO, San Francisco. The increased power of the former station adds to the difficulty.

The progress of Radio was at first rather slow in Norway, but it is now taking rapid strides forward. The main society, "Kringkastingsselskapet," has at present one broadcasting station at Oslo and is constructing two relay plants.

Here's How to Eat to Be Football Star

Tom McNamara, KOA Gridiron Coach, Gives Sidelights on Training —Outlines Menus

DENVER.—Secrets of physical fitness—an essential in training for the gridiron or any other grueling physical test—are knowing how and what to eat, according to Tom McNamara, internationally known football coach at KOA here.

"Drink plenty of water, don't hurry your meals and refrain from eating while fatigued," are a few of his tips to football players. "Another thing, warnings of certain theorists regarding overeating should not be considered too seriously."

In prescribing a diet for football players, Mr. McNamara favors the following: Morning: Fruit, cereal, milk or cocoa, bread, toast, rolls or biscuits and a protein food, either eggs, bacon or meat.

Noon: Vegetable or chicken soup, meat or meat substitutes, two green vegetables, potatoes, rice or macaroni, plenty of bread, one glass of milk or cocoa, fruit desserts and rice or bread puddings with milk.

Night: Steak, lamb, fresh fish or roast beef, two green vegetables, potatoes, rice or macaroni, plenty of bread, milk, fruits in season and sometimes a salad or ice cream.

Mr. McNamara's discussions are featured by KOA every Monday, Wednesday and Friday evening at 8 o'clock, mountain time.

Bureau of Standards Warns About Misuse of Its Name

WASHINGTON, D. C.—The attention of the bureau of standards has again been called to the frequent misuse of its name in connection with the sale of dry batteries for Radio receiving sets.

Claims have been made by some dealers that the superiority of their particular brands of batteries has been shown by tests made at the bureau of standards. These tests are made to aid the government in the purchase of batteries. The bureau does not publish the results.

Therefore, statements that any make or brand of battery is superior as shown by tests made at the bureau of standards are unwarranted.

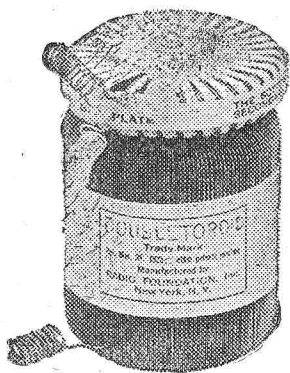

Patented Mar. 31, 1925

The Doubletoroid Coil

"Doubletoroids" can be mounted at any angle or spaced at any distance.

"Doubletoroids" make more selective sets possible, since they do not form miniature loop aeriels.

"Doubletoroids" hold static and other disturbances to a minimum since no current from an external source can influence them.

Outstanding Features of the Doubletoroids

Both primary and secondary are true toroids.

The magnetic path is shortest. It is the most compact.

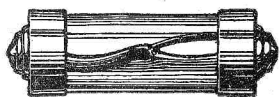

Patented June 16, 1925

It's Variable

The Nonoise Gridleak improves reception because it can be adjusted for every station. Fits standard brackets. Absolutely noiseless. At all dealers and in the better sets.

Nonoise Gridleak

Radio Foundation, Inc.
25 West Broadway New York

Building a Super?

Ryan's Simplest Possible Super-het Manual

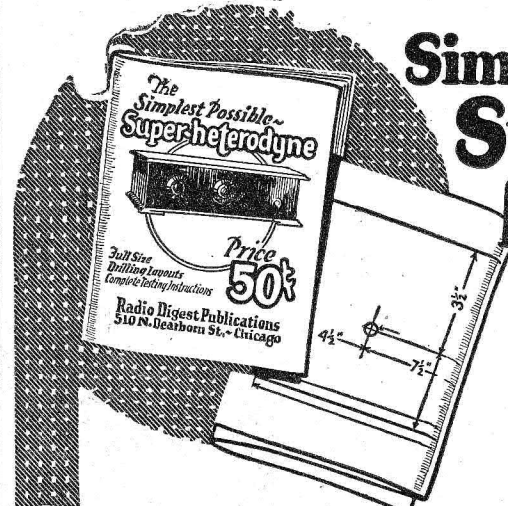

50¢

Full Size Drilling Templates-Loop Aerial Construction

ANYONE who has built a crystal set or single-tube can follow Mr. Ryan's concise, simply worded instructions and enjoy the range available only from a super-heterodyne. Every wire, every lug, is placed by his directions and you cannot go wrong.

The construction of loop aeriels, storage "B" batteries, a charger and even the cabinet are gone into thoroughly. This manual covers the complete installation of a selective, quiet, long range Radio outfit. Send money order, stamps or currency to

Radio Digest Publications
510 N. Dearborn St. - Chicago

Radio Digest Illustrated

Published by the Radio Digest Publishing Company, Inc.
510 North Dearborn Street
Chicago, Illinois
Telephone State 4372, 4373, 4374, 4375

E. C. RAYNER, Publisher

Eastern Office, Park-Lexington Building, 247 Park Ave.,
New York. Telephones: Ashland, 8144, 8145, 8146

Member of the Audit Bureau of Circulations

241
PUBLISHED WEEKLY

SUBSCRIPTION RATES

Yearly in U. S. and Possessions and Canada, \$5.00
Foreign postage, \$1.00 additional. Single copies, 10 cents

Vol. XV Saturday, October 17, 1925 No. 2

That Fourth Radio Conference

THE fourth national Radio conference will be held at Washington beginning Monday, November 9. Many important problems are to be discussed. The three previous conferences, without aid of the much delayed legislation (which is still delayed), solved many of the problems confronting broadcasting and helped Radio's progress to a great extent. It is believed that the fourth conference will do even more in the way of accomplishments than its predecessors.

Why should representatives of the public and all concerns interested in the Radio art, send their representatives to a conference at the national capital? What is to be gained by these representatives sitting at meetings lasting for a week of entire days? What is the good of all this talk when action is what we need?

We shall defend the national Radio conferences. We do not say that each of the three so far held have been of equal success, but at least much worth while has been achieved at each. If we were to summarize them, we would say that the first conference, held before individuals or organizations could predict what Radio would be like today, did all that it could and all that was expected of it. The second conference, the most successful to date, accomplished more than was expected, and as a result, the Radio industry prospered and listeners were able to hear what they wanted when they wanted it, for the whole year following. The third conference, held last fall, however, was in our opinion a most miserable and hardly excusable failure.

The conferees last year met in good faith with a plan of action before them, as was the case in years previous. The biggest part of that plan was to provide an allocation system by which the present (at that time) broadcasters and the future stations would be assigned to wave lengths which would not conflict. The conference did not terminate that business, else we would not have that same problem before us at the fourth meeting. As a result, throughout the past winter, listeners were compelled to submit to the worst broadcast congestion and interstation interference it has ever had the misfortune to know. Did all this help Radio? Hardly.

It is conservatively estimated by several well-known authorities that eighty per cent of the many sets returned last winter to dealers as unsatisfactory—lacking in selectivity—were not at all unsatisfactory or non-selective, but that the broadcast congestion was the root of all trouble. Think of it! Eighty per cent of returned sets were faultless, but returned nevertheless, just because the third Radio conference did not visualize the winter season and the results of an overcrowded air.

The limitation of stations and allocation of wave lengths is to be discussed (and acted on, we hope) at the fourth conference. Methods of doing that which will be proposed will no doubt number about the same as the number of representatives at the conference. Regardless of what plan is accepted, the conferees unable to have their plan accepted must remember that any plan is better than none at all, as was the case this last year.

Let us say, before someone accuses us of attacking Secretary Hoover, under whose jurisdiction Radio falls, that we think he has proved himself the most capable executive ever to hold a cabinet position. He has kept Radio level, despite its rapid growth, and has done it with hardly a law to help him. He has done all by obtaining the cooperation of the public, broadcasters and Radio manufacturers. If you have ever tried to get cooperation out of such a mixed group, you know his task.

We still believe in the national Radio conferences, regardless of the failure to overcome a serious difficulty which loomed before the nation last year. Many other topics are to be thrashed out at the fourth of these meetings besides limitation of stations and the systematic allocation of wave lengths, and we hope that, in the rush, none of these which may prove vital during the ensuing year, is overlooked and left to paralyze broadcasting.

Let's all get behind our various representatives to the coming meeting in Washington, and instruct them not to be spellbound, but TO ACT.

RADIO INDI-GEST

The Voice in My Radio

Tonight, in the magic of midnight
In my study alone;
Around my heart entwines a song,—
Sung through a megaphone.
The singing sounds like an angel,—
I dream of other years,
As through the air the dead days rise
And fill my eyes with tears.

Atuned to the memory of long ago
When she sang the old songs;
And though she is far away from me
Amidst the cities throngs
Tonight, she seems to be singing to me;
O God if she could know,—
That I am tuned in on the ether
Across the hills of snow.

Through misunderstanding we parted
Tonight, my heart's in tune;
Thrilled to hear the songs from her soul
Carols she used to croon;
Who knows but God in heaven,—
Sends her message to me
That we might be united through love,—
That binds Eternity.

RHEA SHELDON.

His Home Companion

It was a dark and stormy night. Alone, seated by the comfortable fire in his well appointed home, sat a man. He paid little heed to the raging and tearing gale without; he sat deep in thought. His train of thought centering on the beautiful music that filled the room.

Over in the corner she did her best to produce melodious tones that would take his mind off the day's work and carry him to the opera, organ recital, dance hall, musical comedy and finally off to Dreamland. He turned toward her. She was pretty. He admired her, not only for the sweet voice that she possessed but for the beautiful effect she caused with the light falling on her that way. Not a blemish and such attractive curves. She was so very versatile, too. Just when he was about to nod off to sleep she broke in with a lively dance tune that set his foot a-tapping.

He was ready to admit that he was well pleased and did not begrudge the price he had paid for her.

Tomorrow he would tell the boys in glowing terms all about his new loud speaker. D. N. M.

After that, Dave, we guess you had better fill the paste pot, there might be some more bears in them mountains!

Stanley, Shall I Jump?

(Continued from the other time)

Synopsis—(Last week's copies contain the story in full, so why should we waste space to tell you something for nothing when we might sell it to you for money? Yah, shure!)



"We were happy—Mae and I—and after a while the baby came. Oh how happy we were—Mae, the baby and I. But I could not leave my secret vice. Every night when all were sound asleep I stole off into the attic and made Radio sets. One night, after many trials, I hit upon the great idea—the superblooper. Flushed with success I dashed to the office of the Radio Corporation of Columbia and offered it to them in exchange for Radio tubes for the rest of my life. But alas! the slickers done me out of my idea and threw me out in the streets. After that drink got me—Coca-cola and Peruna soon made a mockery of what was once a proud man."



"But what become of your wife?" asked the baby, a tear in her blue eye as she kicked the family cat, "what become of the wife, I say?"

"She is now eking out a miserable existence winding low-loss coils for the self same soulless corporation that done me out of my idear."

"And the baby?" added Ma Rayjo, scarcely able to hold the cork back on a bottle of orange crush, "what becomes of baby squawker?"

"The baby is now posing for ads for this same corporation showing how happy home life can be made with electrical appliances."

"Here, kid," said Baby Rayjo, "here's a doughnut coil for you thickly powdered with arsenic trioxide. And the next time you invent something have your lunch checked at the baggage station. Then you can always get your feed back."

Simianly yours,
THE THIRD TROMBONE PLAYER.



Ending the Worst Announcer's Contest

Some time ago some person down in the Crescent city took a crack at a certain New Orleans announcer by nominating him for a place in the Worst Announcers' contest. Since then the mail has been crowded with letters telling us that the Louisianian who took said crevice was all wet. Maybe so, we don't know. He slammed the announcer for the long winded ballyhoo he gave the station owners. Since then we have been able to tune in this station ourselves on many occasions and find that the announcements are now short, thus automatically eliminating the man from the Worst Announcers' contest. But what we wanted to say was this: The contest is closed. We made a short announcement over the air the other night! The cup therefore goes to Indi-himself. There will be no recount.

Pointing the Way



Condensed BY DIELECTRIC

WCAP, Washington, put on the air a concert from the Wardman Park little symphony orchestra which I found to be one of the most enjoyable programs of the week. Those seated in the hall from which it was broadcast apparently entertained the same sentiments, for applause was generous and often spontaneous. Gretchen Hood pleased with her rendition of Gounod's Ave Maria, singing with expression and warmth. Grieg's familiar Peer Gynt suite was likeable if lacking in precision, while Mr. Landon's clear diction was another instance of what may be done by singers to enhance their favor with listeners. We should tune to more of them.

Does the broadcasting of fistic encounters between world renowned boxers make a dent in the box office receipts or not? That is a question which does not require a lengthy answer, I think. If one liked that sort of entertainment and could attend, would he be content to hear only? No. I do not know the percentage of listeners who desire such a feature on their programs, but seldom it is nowadays that the wish is granted. WHN, New York, broadcast the altercation between Dave Shade and Mickey Walker. The static was bad that night, yet the exciting progress of the scrap kept one on edge. Mickey knew I would be listening in—so he won the decision.

Whether has flown the cleverness and originality that marked the paid advertising programs from the Los Angeles and Hollywood stations? It used to be we could turn to them with the assurance that the paid programs would be the best on the air and the advertising features presented in such a way that it did not detract from the musical part. Lately these programs seemed to be quite bald of originality and we miss the sugar coating. Perhaps it is just a summer slump and KHJ, KNX and KFVB will soon be with us again better and bigger than ever.

Scotch dialect has a fascination for most of us whether we be from Bonnie Scotland or not and Scottish airs have a lilt to them which breathes optimism. The majority of the programs broadcast by WNAC, Boston, find some interested listeners to each feature, while few can willingly miss their special broadcasting from theater, opera house, or the Checker Inn. One especially agreeable feature presented not long ago was the concert given by the Royal Scottish entertainers. That deserves mention.

Only admiration is possible when tuned to WTAM, Cleveland, for the splendid transmission from that station—regardless of the form of entertainment. There have been singers appearing before their mike whose contributions added little to the enjoyment of Radio auditors, though few occasions when orchestra concerts fell within that class. Rubenstein's Kammenoi Ostroff has a haunting charm all its own and loses none of it when heard by Radio, unless the orchestration is at fault, which it certainly was not the other evening when presented through the Willard station.

Time spent in listening to one of the Quaker City broadcasting stations, WIP, was not wasted when we were treated to a well-balanced program of piano, violin, cello, and vocal selections by artists of attainment. Bertrand Austin knows his instrument (the cello) as Will Rogers knows his lariat; both compel their mediums to obey implicitly. A repetition of this style of program could displease no one.

The Dos and Don'ts of Antenna Construction

Part III—Construction of Outdoor Masts

By William Fenwick

IN THE present article, the construction of a suitable support for either or both ends of an outdoor antenna shall be described in detail. One which has always been quite popular among the amateurs, and which is also very strong, durable and—one of its best points—quite inexpensive, the total cost being well under \$10, is constructed as follows:

It consists mainly of three two-by-four's supported by guy wires (see figure 1). Although in the sketch a 41-foot mast is shown, this may be made higher or lower according to the builder's fancy, but it is advisable not to lower it below

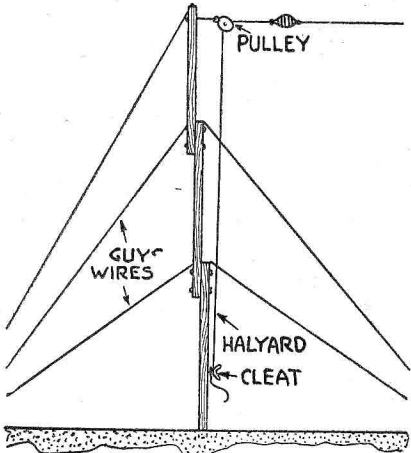

Figure 1

30 feet. The first and second sections are 18 feet in length and the top one, 10 feet. Each joint is bolted together with 1/2-inch bolts and the overlapping at each joint is two feet, as shown in figure 2.

Stranded Galvanized Guys

Stranded galvanized iron, clothesline wire is excellent for the guy wires, as it possesses good strength and will not rust quickly. Four guy wires are fastened to each of the first two joints and one wire

to the top. This latter must be attached to the side opposite that of the pulley so as to take the strain of the aerial. For receiving purposes, one insulator is sufficient in each guy wire, although it is best to insert one every 20 feet if the antenna

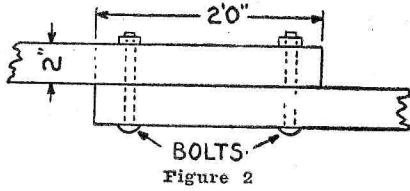

Figure 2

is to be used for transmission as the absorbing power of the metal wires is much greater for the latter purpose.

Erecting Mast

Erecting the above mast, it should be remembered, is not a one-man job nor can it be erected in the usual half hour. A hole one foot deep should be dug where it is to stand and the end slipped into place. Next, your two or three assistants should stand a small distance away, each having hold of a guy wire, finally hoisting it into place, and then fastening each guy to a firm peg or stake driven into the ground, a fence, or to other surrounding objects which you consider strong enough.

The pulley should not be forgotten nor should the halyard, as it will mean an unpleasant climb to the top later, or possibly the undoing of the complete mast merely to secure the pulley in its proper place.

Why Not Iron Pipe?

Although the beginner will perhaps fancy an iron pipe being better than a scantling, he will find on erecting that it is a much bigger proposition to install a 30- or 40-foot length of the former on account of its wabbliness; also it is more costly than wood.

For masts over 50 or 60 feet in height, however, it is advisable to use some material other than wood for construction, as the strain at this height is too great for wood to withstand for a very long

period of time. The best design of masts to employ for antennas which are higher than the above, are those composed of lattice-work.

It might be asked, then, why a commercial station sometimes uses the type sketched in figure 1, having them several hundred feet in height. The reason is that the guying necessarily has to be very elaborate and generally is beyond the capabilities of the average listener. Moreover, there is seldom sufficient space around the mast's location for the fastening of the numerous guy wires.

Slant Roof Mast

If the opposite end of the antenna is to be attached to the roof top and if the roof is of the slanting variety, the two

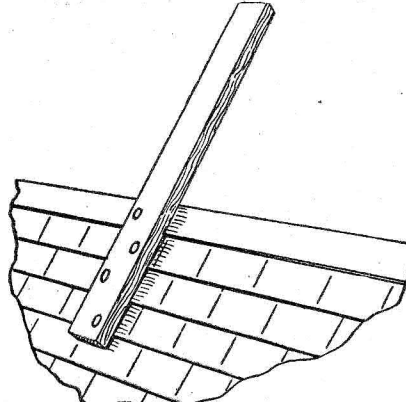

Figure 3

methods illustrated in figures 3 and 4A show about the easiest ways of doing it.

If the peak runs at right angles to the antenna, a piece of wood, preferably a two-by-four, is fastened as in figure 3 with 5-inch screws. To add more strength, the screws should be driven in slanting as in figure 4B.

The exact length of the piece will depend on just how steep an angle the roof slants; the steeper, the shorter

the length of wood needed to keep the antenna a required height above the roof.

Size of Stock

If the peak runs in the same direction as the aerial, then you should make use of the method shown in figure 4A. The

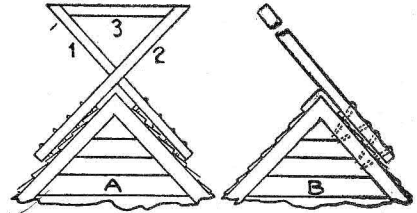

Figure 4

cross pieces (1 and 2) may be of two-by-four's or smaller stock in this case.

The best length for these is approximately five feet as the aerial wires can be stopped a few feet from them thereby providing ample clearance of the roof with the consequence that the support need be only two or three feet high.

The cross piece (3) at the top may be omitted if two wires are used, but is necessary if the antenna is a 1- or 3-wire type.

Precautions in Aerial Stringing

When installing your antenna keep the following foremost in your mind:

Do not under any circumstances run the aerial near to any wires which happen to be in the vicinity. If there are some such wires, have the aerial not less than 20 feet away from them, are more if possible. It is bad practice to cross wires at right angles, for should the top wires, carrying high voltage perhaps, collapse, the receiver may be damaged and ruined, and if the operator has the phones on he may receive a serious shock. This is impossible, of course, if the antenna is disconnected from the set.

Remember, if the antenna is run close and parallel to power or telephone wires, a continual buzzing sound will always be present in the receiver.

(TO BE CONTINUED)

Underground Aerial Aid

I do not know whether I am original in this idea but I have never seen it published. I tried the underground aerial described in Radio Digest, and made an addition to it which improves it very much. I have a 75-foot long piece of No. 14, rubber and braid covered wire and a No. 14 bare copper wire buried with it, 18 inches deep in the ground. (Editor's Note.—The depth should be 4 feet.) I insulated the end of the covered wire by putting the end in a small bottle and filling with battery wax. The bare wire is attached to the ground binding post and the covered wire to the aerial post. Where the two wires come out of the ground

and to the set I wound the bare wire around the other one.

While this does not completely cut static, it muffles it and cuts the harsh crackling. It is not directional and there seems little if any difference in volume

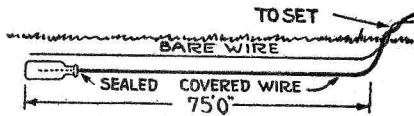

when compared to the outside aerial. The set tunes sharply on the antenna system, and requires but slightly more regeneration.—J. A. McCartney, Larimore, N. D.

Assemble Your Own Radio Cabinet and SAVE \$20.00

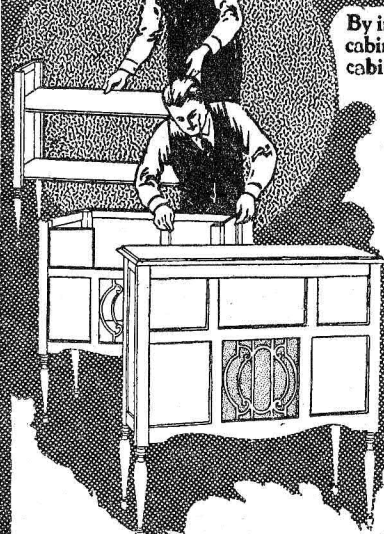

By installing your radio set in this handsome console cabinet you increase its value \$50 to \$100. Similar cabinets ready-made cost \$40 or more in stores. Buy direct—assemble it yourself—and save 50%.

Easy To Assemble

... No bolts, nails, or glue. Just 10 minutes easy work and you have a beautifully finished Rembrandt Radio Console, 36 in. high x 34 in. long x 13 in. deep. Rigid patented construction: front of cabinet adjustable to any standard panel size. Roomy compartments for loud speaker, charger and batteries. Makes your set just like expensive ones seen in best radio shops.

Free 30-Day Trial Satisfaction Guaranteed

... Just mail coupon and we'll ship cabinet in corrugated carton, by express prepaid, to any point in United States. Just deposit \$19.95 with expressman—assemble and use cabinet 30 days—then if you're not convinced it's a wonderful bargain, return cabinet and we guarantee to refund your money at once, less shipping costs only.

SEND NO MONEY

Just Mail Coupon Now!

Name _____
Address _____
City _____ State _____

Earn Your Own Cabinet ... Be Our Agent ...

... Because this console is such a sensational value at \$19.95 you can easily take orders from friends and visitors. We supply No-Money-Down order blanks and give you 20% Commission. Five orders pay for your Console.

Make it a GOOD Set by Using Belden Products

TWO things are important when you build a radio set: First, the workmanship in arranging and connecting the units, and second, the quality of material used.

No amount of good workmanship can compensate for poor material. For this reason, Belden radio products are used by many of the largest radio manufacturers. Belden radio products are available to you, too, in handy cartons, each labeled and guaranteed for your protection. There are dozens of items, each designed especially for some place in your circuit. Our attractive booklet, "Helpful Hints for Radio Fans," describes them all, with diagrams and illustrations. Every set builder should have this booklet.

Send for Free Illustrated Booklet

Belden

BELDEN MANUFACTURING CO.
2310F South Western Ave., Chicago

Please send me your booklet entitled "Helpful Hints for Radio Fans."

Name _____
Address _____
City _____ State _____

The Reader's View

Favors Superpower

In reply to the article written in the columns of the Radio Digest, issued August 29, pertaining to unnecessary interference, written by a professor of Rensselaer Polytechnic Institute and pertaining to WHA's experiments in regard to Radio reception, I will state that I beg to differ with him.

He states in his article that Radio noises cannot be entirely eliminated except by sacrifices. He is correct, so to speak, in one sense of the word, but not as he states. He says that the problem consists in obtaining a low power level and that there is no need of superpower as the 500-watt station can be heard consistently throughout the cold weather all across the continent. He also states that to limit this noise they must limit the amount of power in the broadcasting medium and states that problem consists in the low power level.

I differ with Professor Williams by upholding that superpower is far superior to any broadcasting since stations took the air. First, because it produces Radio reception clearer with less static and more volume. In linking several broadcasting stations together when there is something of national importance to be broadcast, instead of a benefit in any way, it is a hindrance to clear reception as it distorts the signals, whereas coming from one superpower station it has a direct force back of the broadcast and renders reception clear and distinct.

Static and all the other atmospherics are in the air and always will be, and the only way to eliminate this troublesome bugbear to Radio reception is to build a receiver that will receive only the broadcasts clear and distinct.

You may say this cannot be done, but it is done as I have a set of my own construction which will receive all broadcasts through static and all other atmospheric conditions. As I stated, static and all other atmospheric conditions exist and always will and I can hear the same on this set, but it does not interfere with the reception inasmuch as the set sifts all reception right through this bugbear to Radio.—E. A. Lamb, Waterbury, Conn.

Against Chicago Silent Night

I am a listener in to Chicago on the so-called "silent night" and I hope the Chicago stations keep on the air every night of the week.

I have a five-tube set. It is not a superselective one, but can tune out both KDKA and WCAE at any time although about nine miles distant and they hog the air sometimes the entire evening. If I want to hear them I have to tune them in the same as other stations.

We do not have silent nights here in the East and I for one do not want any.

One writer has said that there were tens of thousands of fans in the Chicago district who had costly sets that would like to have a silent night. I suppose he is right, but there are hundreds of thousands of fans that do not have costly sets that would not be able to get any good entertainment at all.

I am for entertainment every night. If I do not care to listen to the local stations, I cut them out and get the ones I want. My vote is cast that way.

I have been a constant reader of Radio Digest for a long time and have obtained some very valuable information from reading it, some of which told how to cut out local station interference.—W. J. L., New Kensington, Pa.

Football's Not So Bad

Allow me to take exception to the published view of P. C. H., Stanford, Conn., in re the relative dangers of football and baseball.

I played four years in both sports while in high school and have played as a semi-professional in both for four years since. In my opinion it is fifty-fifty as to injuries.

There are just as many players hit by balls, spiked and run into, just as many break a leg sliding, take hard falls in base running and fielding in baseball, and the injuries, taken as a whole, are just as serious as in football.

How to fall in football and how to slide in baseball are the chief points players must know to avoid injury. Ask anyone who has played both. K. C. R., Mason, Mich.

Football Must Be Good

In the "Reader's View" column recently, P. C. H., Stanford, Conn., says he is correcting an erroneous statement that you made about football not being any more dangerous than baseball. You were right at first. P. C. H.'s statement is very much in error.

If you will look at statistics you will see that about four men are killed in baseball every year to one in football. Does that sound as if football is more dangerous?

Tell P. C. H. to watch the number of fatalities in football and baseball and then change his statement. P. L., Russellville, Ark.

An Undeserved Bouquet

Ever since your paper came on the news stands I have faithfully followed each issue with increasing enjoyment. Whenever I desire to have company listen

to a good program, Radio Digest supplies the station and date.

That advance program material is worth a year's subscription alone.

More recently I have chuckled over "Distilled by the Third Trombone Player," for he certainly takes a crack at "Dielectric," who seems to furnish plenty of material for his fire.

I always read everything on the editorial pages and believe they represent the future aim of listeners in and broadcasters—at least you are doing your share to help Radio broadcasting.

With best wishes for Radio Digest.—W. V. C., Philadelphia, Pa.

Removable Spider Web Former

I am herewith describing an improved spider web coil form. The coil, instead of being wound on a cardboard or fiber form, is wound on an iron form (brass or aluminum would do as well), the segments of which can be removed with great ease. Besides removing the segments with greater ease, this form has the advantage of being able to withstand the use of large size wire such as Nos. 16 or 18, whereas other forms break when this size is used.

The segments, cut from a circular disk as shown in the sketch, are mounted to

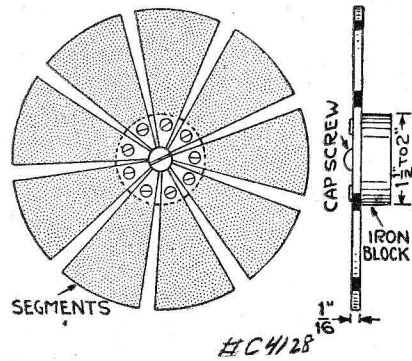

an iron block (round), one and a half to two inches in diameter. A cap screw holds each segment to the center block while another screw in the exact center further holds all the segments in place. Bolts extending through the block can be used instead of cap screws which, of course, require threading of the holes in the block. The edges of the segments are rounded to prevent cutting of the wires.

The finished form will be the same as any other spider web form in appearance, and winding is done as in winding other

similar coils. When a coil is wound, bind the connections with thread or apply a little collodion on the places where the wires cross. This will hold the coil together. The screws are then taken out and the segments removed with ease. A finished low loss coil remains.—Allen Bartlett, Milwaukee, Wis.

Bus Bar Eyelet Forming

This is an easy method of making a good connection at the ends of bus bar wiring which is much better looking at least than the soldered variety. Turn a well-formed eye in the end of the wire, the eye to be a little smaller than the threaded portion of the terminal post over which it is to go. With a smooth faced hammer, on a smooth iron surface, flatten the eye. It may be hammered down as thin as you may wish. This will give you a good flat surface.—W. C. VanNess, Fayette, Iowa.

It is better to get moderate, clear signals than loud, distorted ones.

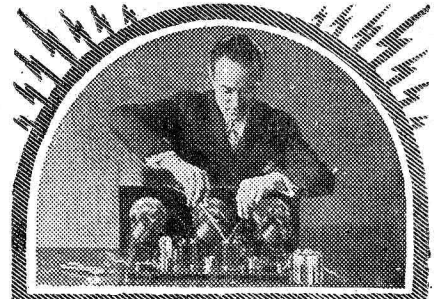

EARN \$50 to \$200 A WEEK!

Become a Radio Expert

THIS is the time to get into Radio—the new, fast growing, uncrowded profession. Stop working long hours for small pay at work that is drudgery. Men from all walks of life are taking advantage of the big opportunities now open in this wonderful new industry. Salaries of \$100 a week—and more—not at all uncommon!

Learn at Home

You can train for this "big money" field right in your own home—in spare time. No matter how little you know about electricity or Radio, the National Radio Institute—the largest and oldest home-study Radio school in the world—established 1914—can quickly make you an expert through a marvelous method of practical instruction—which includes all necessary parts for building up-to-date receiving sets.

Big Demand Now

Almost every day we get urgent calls for our graduates. The big jobs hunt you when you are a Radio expert. Radio offers you more money than you ever dreamed possible—a chance to travel or to take any one of the many Radio positions all around you at home. Offers you a glorious future!

Send for FREE Book

Write today for free book "Rich Rewards in Radio." Tells all about this great new money-making field—and describes our amazing practical method which trains you for the bigger paying jobs in Radio. No obligation. Mail coupon now. National Radio Institute, Dept. 55MB, Washington, D. C.



The National Radio Institute, Dept. 55MB, Washington D. C.

I am interested in Radio as a profession. You may send me, free and without obligation, your interesting book, "Rich Rewards in Radio," all information about your spare time, home-study plan and about your free employment service. Also, the details of your Special Offer.

Name..... Age.....

Street.....

City..... State.....

The Console Master Speaker

for ANY RADIO set

RETAIL PRICE
\$49.50

Complete with Loud Speaker Unit

"Makes Radio a thing beautiful in your home"

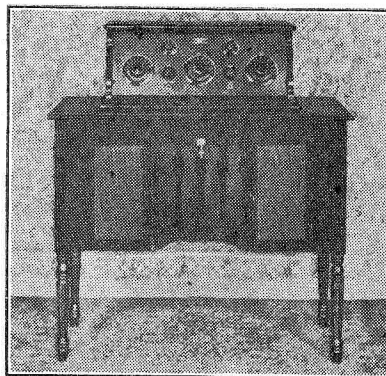

One pull of the handle opens the front for adjustment of batteries or Loud Speaker Unit.

A magnificent table on which to stand your Radio Set with ample space to hold and conceal all batteries, charger, wires, etc. The Loud-Speaker is built-in, like a phonograph, and is vastly superior in tone to the old fashioned horn speaker.

No more ugly horns, or wires, or batteries visible, everything concealed—shut out of sight. Yet—everything instantly accessible! One pull of the handle opens the whole front for adjustments, etc. Ours is the only Console Speaker with this feature.

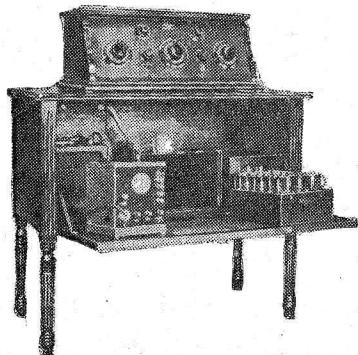

This is why the CONSOLE MASTER SPEAKER is the most practical Console Speaker built. Refuse imitations. Insist on the genuine.

CONSOLE MASTER SPEAKER CO.
15 East 40th Street
NEW YORK CITY

Inquiries from responsible Dealers and Jobbers solicited.



Oh boy!

KESTER
Rosin Core
Radio SOLDER

Sure is Safe and Simple

APPROVED BY
RADIO ENGINEERS
A Genuine Solder

CHICAGO SOLDER COMPANY
4236 Wrightwood Ave., Chicago, U.S.A.

Originators and World's Largest Manufacturers of Self Fluxing Solder
Your Dealer Can Supply You

'Traveler' Doughnut Coil Tuned R.F. Receiver

Part II—Drilling and Assembly

By John G. Ryan

IF THE parts listed in the first article of this series are all at hand we are now ready to drill the front and sub-base panels and mount the various pieces of apparatus on them. The reader has two alternatives at this stage of construction; the directions and diagrams given below can be followed to lay out three full size drilling templates, or, he can write in to Department 5, Radio Digest, 510 N. Dearborn street, Chicago, Ill., and enclose 25c for full size blue print templates. They

The outer edge of each should be 1/4 inch in from the ends of the front panel, as we are later going to take half an inch off the sub base which amounts to 1/4 inch at each end. Now, with the pencil, mark through onto the back of the panel. Measure the distances these marks are from bottom and ends and put crosses corresponding to them on the 24 by 7 template. Now paste the template to the front of the front panel with four little drops on the corners, or use clamps if you have

drilled so that just a paper thin wall separates each hole. This is the method used by the writer. Then, with a sharp screw driver and hammer, cut through the thin walls all the way round and the disk should drop out. Now with a half round file, smooth down the edges of the hole to the line. Figure 4 shows where each of the parts goes; the condensers should be mounted at an angle with the short edge of each horizontal. The jack in the lower right corner of figure 4 is a

one end, so it will slide into the cabinet. Two diagrams are necessary to show the holes to be drilled in the sub base. You can combine them on one template or make two templates to avoid confusion. The holes necessary for mounting parts are shown in figure 5, while those through which wires pass are indicated in figure 6. The writer would suggest making a template per figure 5, pasting it on, center punching, and drilling the holes required as one operation. All holes shown there

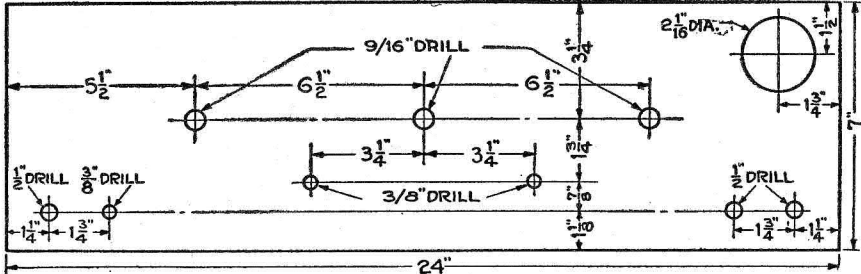

Figure 3

will be sent promptly on receipt of this amount in stamps, silver, or money order. If the former course is chosen, figure 3 shows the exact location of all holes necessary on the front panel. To get these holes marked on the panel, first cut a sheet of paper to 24 by 7 inches for a template and then, with ruler and pencil,

them. Lay the front panel on a flat surface back down, and with hammer and center punch, prick each hole through into the panel. This should require but one moderate tap of the hammer. When this is done for each hole, lift off the template and wash the corners of the panel. Now drill according to figure 3, starting

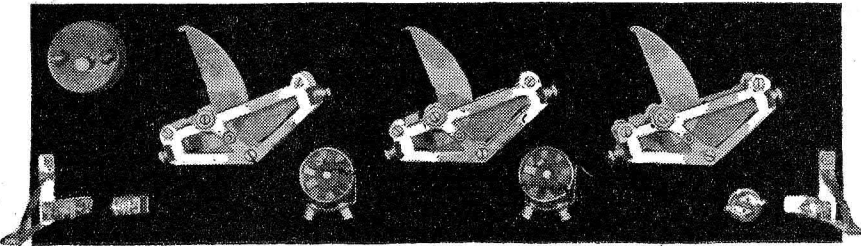

Figure 4

make a small cross where each hole is to go, following figure 3.

Bracket Holes

Bracket holes have not been shown in this illustration as these will vary depending on the brackets used. To get them just right, lay the front panel face down on the table; on it set the panel which is to be the sub base, with one long

the large holes with a small drill, about 3/32-inch or No. 27. Then use the large drill. If your collection of drills does not contain one large enough for the condenser mounting holes, a reamer is necessary to bring them up to size.

Mounting the Meter

The meter hole may present some difficulty if you have never installed a meter

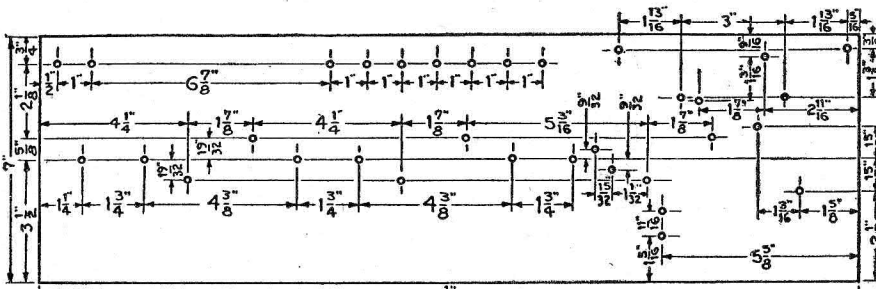

Figure 5

edge down and so that one surface of the sub base is 1/8 inch from the edge of the front panel that will later be the bottom. The upper surface of the sub base will then be 3/8 inch from the bottom as the panel is 1/2 inch thick. Now place the brackets in the angle just formed.

on a panel before. There are two ways of doing this. You can either use the fly cutter made for the purpose by the Jewell company, which is perhaps the easiest way, or, you can draw a circle 2 1/8 inches in diameter and drill about twenty small holes just inside this line. They are to be

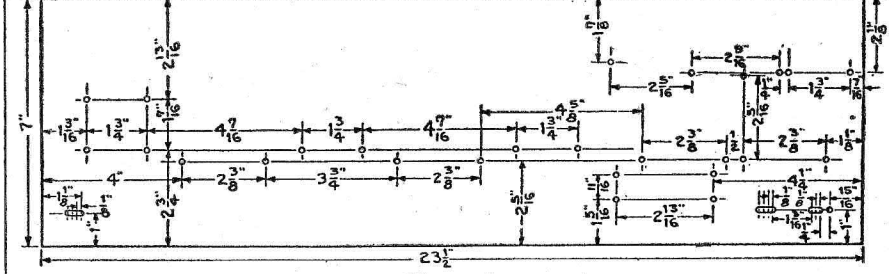

Figure 6

four-spring two-circuit jack; that in the lower left corner is the filament control jack. The one next to it is the second two-circuit jack. It will be noted that the writer hung his baseboard on the underside of the brackets. These brackets were bought from the Chicago Salvage Stock Store, 509 S. State street, Chicago, at 15c each.

The sub base panel should now be cut to 23 1/2 inches long by taking 1/2 inch off

are for 6-32 screws and a No. 27 drill is correct. Then make the template as per figure 6, paste it on, center punch and drill with as small a drill as will pass the bus wire you have purchased. This will be about 1/8 inch. To determine the positions of the bracket holes, and presuming you have the brackets on the front panel, place the sub base under the brackets so that the rear edge is 9 inches from the (Continued on page 20)

Tuning Through Static

The deafening effect of static when the sensitivity of a receiver has been increased to the utmost and one is tuning through for a distant station, may be decreased considerably by placing the phones just in front of the ears instead of directly over them. The fact is, that, even if the phones are placed completely over the ears, in front of them, the desired signals can be heard.

phones are placed with the edge just over the ear opening, the desired program and announcements can be heard very distinctly, and the static will be found to be decidedly diminished not only causing less shock to the ear, but, in addition, causing much less interference to the reception.—H. A. Fackboner, Terre Haute, Ind.

However, for ordinary stations, if the

It is important to have a test buzzer if a crystal detector is used.

The New Radio Book

HOW TO

Operate Sets

Construct Parts

Improve Reception

Understand Radio

Assemble Circuits

The greatest assemblage of facts and hints, from actual everyday practice, ever gotten together. Edited by the technical staff of Radio Digest, it supplies the demand for a book covering every phase of Radio. Starts at the beginning with simple explanation of Radio reception, with technical explanations of the different parts and leads right on to the more advanced instruction. A complete handbook serving as a ready reference in the Radio field. It gives suggestions on parts and sets which will prove to be a money saver. Blue prints and diagrams are essentially an important part of this book. Special chapter is devoted on "How to Operate," which gives detailed information on the operation of many well known sets.

A general information is vital to the knowledge of anyone interested in Radio. It gives a complete list of all broadcasting stations with a colored map showing their location. The workshop kinks will save you time and money. Now is the time to take advantage of this exceptional offer. **Mail coupon today!**

RADIO DIGEST,
510 N. Dearborn Street,
Chicago, Illinois.

Enclosed find \$5.00 for one year's subscription to Radio Digest. The new Radio Book, "Radio Receivers," will be mailed FREE, postage prepaid. This offer only good on subscriptions sent directly to this office, not through agents or agencies.

Name

Address

City State

10-17-25



Vigilance
Constant vigilance
is the price of
uniformity
and constant vigilance
is maintained
over Magnatrons.
That is why Magnatrons
are uniform, and
uniformly good.

The Magnatron DC-201A, DC-199, and DC-199 (large base) now list for only \$2.50 each.

CONNEWY ELECTRIC LABORATORIES
Magnatron Building Hoboken, N. J.

MAGNATRONS

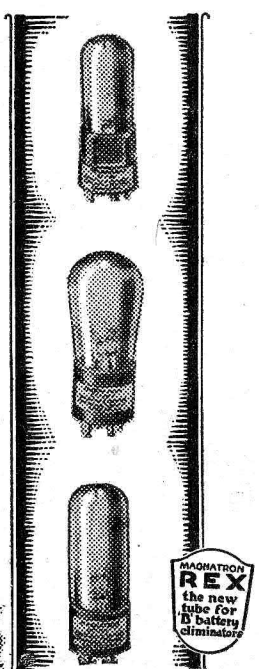

MAGNATRON
REX
the new
tube for
B Battery
eliminators

A. B. C. Course in Radio Fundamentals

Chapter XXX—Applications of the Electron Tube Oscillator—Continued

By David Penn Moreton

THE three electrode vacuum tube oscillator circuits have found wide application in undamped wave Radio telegraph receiving as well as in undamped waves is the heterodyne method, most efficient methods of receiving undamped wave is the heterodyne method, which involves the generation at the receiving station of a high frequency alternating current, having an adjustable frequency near that of the incoming undamped oscillations. The generation of this high frequency current may be effected by means of a three electrode vacuum tube connected as an oscillator. It is possible to use a single vacuum tube for both detection of the incoming oscillations and for the generation of the local oscillation.

An arrangement operating with a single tube is shown in figure 122. The grid and plate circuits of the tube are coupled to each other by means of the coils L_p and L_g . The locally generated oscillations are set up in the circuit $L_g C_2$, and the circuit is thus seen to be similar to the one shown in figure 113, in a previous chapter. The plate circuit is energized by the battery B and includes the telephones T. The incoming signals are received on a tuned antenna circuit coupled to the grid circuit of the tube. The grid circuit also contains a condenser D shunted by a high resistance R. The

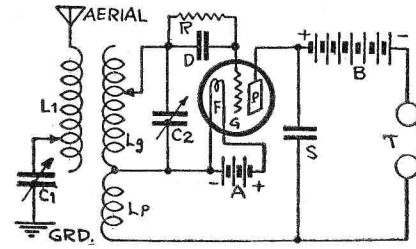

Figure 122

operation of this circuit may be described briefly as follows: The antenna circuit is tuned to the frequency of the waves to be received. These waves then set up in this circuit, strong oscillations of their own frequency which, by induction, produce corresponding oscillations of the grid potential of the tube. But the tube being in an oscillating condition, locally generated oscillations are also set up. The locally generated oscillations are of the frequency of the circuit $L_g C_2$, which is adjusted to a frequency slightly different from that of the antenna circuit. There are, thus, two alternating electrical pressures of slightly different frequencies impressed upon the grid. The operation of the tube resulting from these two frequencies is such that a plate current having a beat frequency equal to the difference of the two frequencies is produced. For suitable values of grid, plate and filament battery voltages, it is then possible to bring the direct current operating point of the tube where it will act as a rectifying detector for incoming oscillations while still oscillating. Variations in

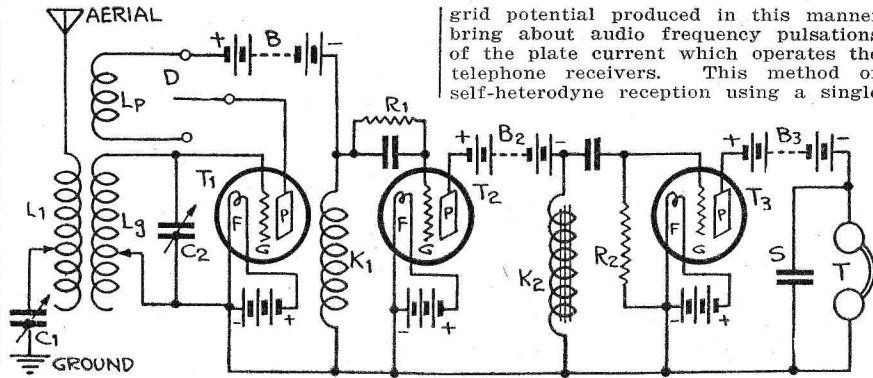

Figure 124

tube for the operations of detection and oscillation generation is called the auto-dyne method of reception. The purpose of the condenser S is to bypass the locally generated high frequency oscillations which would otherwise be absorbed in the plate battery and telephone receivers. The audio frequency, that is, the pitch of the sound in the telephone receivers, is directly dependent upon the original oscillating frequency. By using an audio frequency tuned telephone circuit, it is possible to increase greatly the intensity of the received signals and to increase considerably the selectivity of the receiving circuit by the use of several tuned oscillatory circuits in succession. A circuit illustrating this suggestion is shown in figure 123, which differs from the circuit shown in figure 122, only in that the telephone receivers instead of being directly connected to the plate circuits of the tube, are connected to an oscillatory circuit coupled to the plate circuit, and tuned to the beat frequency, that is, to the difference between the frequency of the locally generated currents and of the incoming oscillations. A circuit that might be called a universal receiving circuit is shown in figure 124. It comprises an antenna circuit tuned to the frequency of the signal waves being received, and three vacuum tubes in cascade. The first tube T_1 is coupled to the antenna circuit through its tuned grid circuit. There is a switch D connected in the plate circuit of the first

tube, which, when closed in the upper position, disconnects the coil L_p and, when closed in the lower position, connects the coil L_p in the plate circuit of the tube. When the coil L_p is disconnected the first tube acts as a high frequency amplifier and the circuit may be used for the reception of damped or modulated wave signals.

With the switch D in the lower position, or when the coil L_p is connected in the plate circuit, the plate circuit is coupled to the grid through the coil L_p , frequently called a "tickler coil." If this coupling is very loose, then the first tube acts as a regenerative amplifier, for use with damped wave signals. If the coupling of the plate and grid is close, the first tube generates oscillations, and is used for heterodyne reception of undamped waves. The second tube T_2 is a rectifying detector and the third tube T_3 is an audio frequency amplifier. Choke coil coupling is shown in figure 124, but transformer or

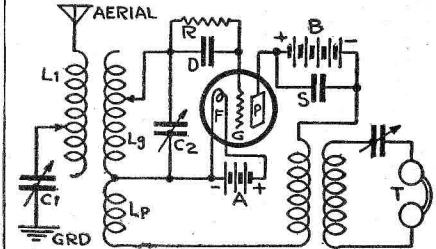

Figure 123

resistance coupling may be used equally well.

With the heterodyne method, the note in the telephone receivers may be adjusted as desired to correspond to the frequency at which the telephone receiver diaphragm is most sensitive, or to suit the ear of the receiving operator, or to be easily read through interfering signals from other stations so that interference from other stations is reduced to a minimum. A slight difference in the frequency of the interfering signal would give a note of entirely different pitch, or a note which would be entirely inaudible.

(Prof. Moreton will next show how oscillators are coupled to voice frequency modulators.—Editor's Note.)

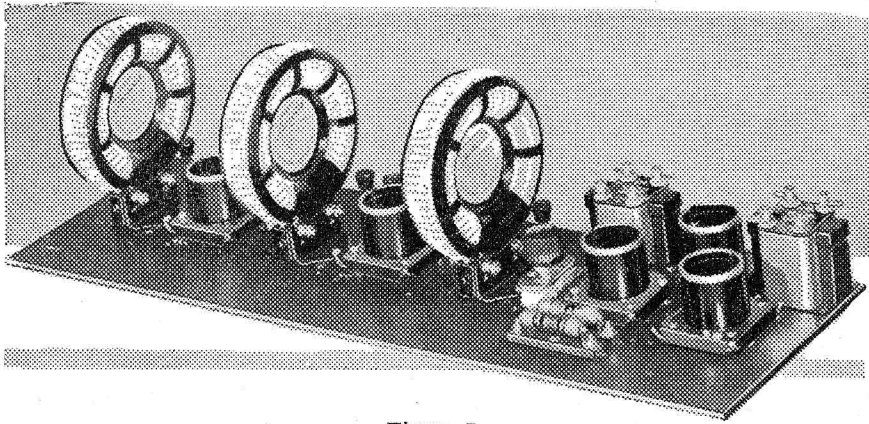

Figure 7

"TRAVELER" RECEIVER

(Continued from page 19)

front surface of the front panel. Now mark with a pencil through the bracket holes and drill for 6-32 screws. The positions of the parts on the sub base are shown in the photograph figure 7.

Since first building and testing this set, and making the template drawing figure 6, the writer found a way of simplifying the writing at the right end of the sub base which makes necessary three holes not shown in figure 6. To get their locations, mount the two audio frequency (Continued on page 21)

A FACT!

The only man who doubts that a 3-tube set can give better results than a 5-tube set, is the man who has never made a performance comparison between the Crosley Super-Trirdyn and the best 5-tube set built.

Super-Trirdyn Regular, \$45

THE CROSLEY RADIO CORPORATION, Cincinnati, Ohio

CROSLEY RADIO

BETTER · COSTS LESS

Guaranteed
AIRLINE
RADIO
Sets and Parts

MONTGOMERY WARD & CO.
Baltimore Chicago Kansas City St. Paul Portland, Ore. Oakland, Calif. Fort Worth

Ward's New Radio Catalogue Is Yours Free

Yours Free—the newest, most interesting book published on Radio. A book prepared by Radio experts—a complete Radio manual.

52 fully illustrated pages showing what is new in Radio and what has been approved by the best experts.

It shows sets from one tube to five tubes, the new one dial control, parts and supplies, batteries and cabinets. It gives a list of stations, a radio log for recording stations.

Headquarters for Radio

Ward's is today one of the greatest Radio stores in the world—selling

Write for your free copy of Ward's new Radio Catalogue
Address Dept. 41-K

Montgomery Ward & Co.

ESTABLISHED 1872
The Oldest Mail Order House is Today the Most Progressive
Baltimore Chicago Kansas City St. Paul Portland, Ore. Oakland, Calif. Ft. Worth

everything in Radio without the usual Radio Profits. And besides, we sell only the tested and approved equipment—selected and tested by our own experts, who are up to the minute in Radio. Thousands of customers write us of their delight and saving on Ward's Radio sets.

Our 53 year old Policy

For 53 years we have sold only quality merchandise under a Golden Rule Policy. You can rely absolutely upon the quality of everything shown in this Radio Catalogue.

Complete Data for British Circuit

Fans Call for Details and Fill Writer's Mail

IMAGINE yourself, fellow fan, a quiet, peaceful citizen of the sovereign state of Pennsylvania. You have an unusually good Radio circuit which gives you excellent results on DX and you decide

WORKSHOP KINKS EARN A DOLLAR—

THERE are many little kinks worked out at home that would aid your fellow Radio worker if only he knew about them. There are new hook-ups, new ways of making parts and various unique ways of operating sets that are discovered every day. Radio Digest is very much interested in obtaining such material. Send them in with full details, including stamped envelope, so rejected copy may be returned. The work must be entirely original, not copied.

RADIO KINKS DEPARTMENT
Radio Digest
510 North Dearborn St., Chicago

that, for the good of all fandom, you will send it in to your favorite Radio magazine that all may try it. Nothing happens for several weeks, then suddenly you get an avalanche of mail to the extent of over 600 letters in a week. It is manifestly impossible for you ever to answer all that correspondence; you're not Sears-Roebuck nor Montgomery Ward. You hate to seem unobliging, yet you naturally can see no reason why you should be burdened with the work and expense of answering that pile of mail.

That is what happened to Mr. Joseph Stevenson when he contributed his kink and it was published in the August 29 issue. Mr. Stevenson sent in the data with his kink but the technical editor purposely omitted it for two reasons. First, it did not appear necessary since it seemed to the editor that by this time most of the experimentally inclined knew the size condenser to use with certain coils, etc. Second, he wanted to see what the readers would do with it. The necessary information was all in Radio Digest copies of this year, particularly the issues of February 28 and March 21. This action is sincerely regretted now, and apologies are extended Mr. Stevenson for the inconvenience this may have caused

M-B-G RADIO CABINETS



No. 31 Radio or All Purpose Table \$3.50
15 x 31 x 29". Substantial, rigid table that can be used for a thousand purposes.
Our Radio Cabinets are furnished in the natural wood only. Beautiful color card with instructions for finishing sent with each cabinet. Made of beautifully grained Fir Wood.

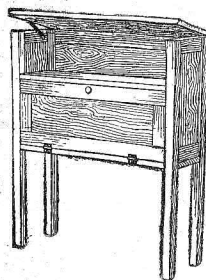

NEAT FIT K. D. CABINETS
Made in a variety of sizes sold knocked down, easily set up. Holes bored for every screw. No other cabinets offer such unusual values.

No. 37 Cabinet 7 x 18" panel, 9" deep. Battery Compartment \$10.50
Additional door in front of panel forms arm rest when open.....\$3.00 extra.
No. 37—panel sizes 7 x 24", 7 x 26" and 7 x 28". Other sizes carried in either size.....\$11.50

At \$5.00 extra our Console Cabinets can be furnished with built-in loud speakers. The tone chambers of our speakers are made of Pyralin and give forth a full resonant tone. No better made; neat, compact, efficient.

Illustrated circular on request.
RADIO CABINET DEPARTMENT
Express Body Corporation
43 Lake St. Crystal Lake, Illinois

HOOK-UP THAT TUNES IN AMERICA

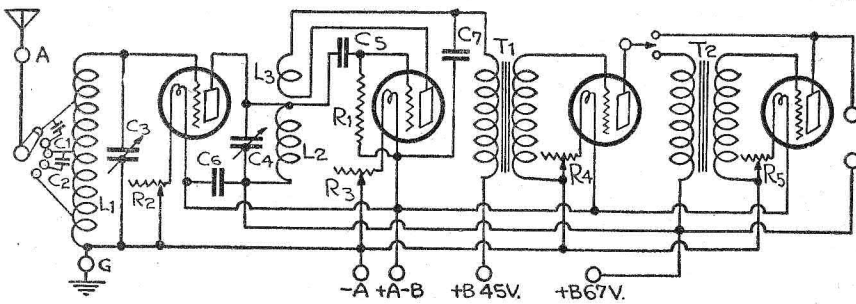

him. Here is the list of values for the various parts used in this circuit:

If the builder has two variable condensers of .00025 mfd. capacity for use as C3 and C4, the coils L1 and L2 should contain 99 turns of No. 22 dcc. or 82 turns of No. 24 dcc. wire if wound on 3-inch tubing. If the condensers available are .00035 mfd. the coils should contain 70 turns of No. 22 dcc. or 66 turns of No. 24 dcc. on this same size tubing. Should the condensers be of the .0005 mfd. size, the coils are to have either 55 turns of No. 22 dcc. or 51 turns of No. 24 dcc. wire on 3-inch tubes.

The fixed condensers C1 and C2 are to be of .00025 mfd. capacity, as is condenser C5. This latter unit may also be .0005 mfd. if you have it. C6 is a bypass condenser of .5 mfd. capacity and C7 is another of .001 mfd. or .002 mfd. capacity. The tickler L3 will contain from 20 to 40 turns depending on the size tubing used and the coil (among those listed above) with which it is to be used.

The grid leak R1 should preferably be variable, but if of the cartridge type, will be between 3 and 5 megohms depending on the tube used as detector. R2, R3, R4 and R5 are each 30-ohm rheostats. When choosing the audio frequency transformers T1 and T2, use care not to get two of too high a ratio nor two of too low a ratio. For example you could have the first be a 6 to 1 and the second 2 to 1, or you could have both be 4 to 1 or 3 1/2 to 1. Both should not be 6 to 1 or 2 to 1.

There you have it all, readers, and let the technical department know how you come out. A number of those who took the trouble to figure out the probable constants themselves have advised splendid results. You can use either the 201A or the 199 tubes; the antenna can be of any length between a 40-foot indoor and a 110-foot outdoor installation. You do not necessarily have to use tube wound coils; space wound, spider web, basket weave, honeycomb or bank wound inductances may be employed.

"TRAVELER" RECEIVER

(Continued from page 20)

transformers and the socket which goes between them. The Fil. and Grid terminals of each transformer go toward the rear while the P and G terminals on the socket also go to the rear. It will be noted that mounting holes for the right hand transformer have been drilled only for the holes in the transformer in the rear right and front left corners. With the pencil, mark through the hole in the rear left corner onto the sub base. Now mark a small cross on the sub base 1/4 inch to the left of the rear left mounting hole of the left hand transformer. Another cross is to be marked just to the right

FREE!

Autoformer Hook-up Bulletin. Write today

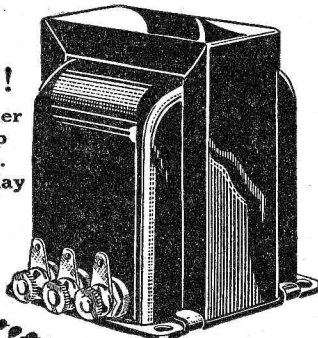

There is no variation in amplification over the entire range of musical frequencies with Thordarson Autoformers. No note is too low—no note is too high to be fully amplified by the Autoformer. In addition there are three other advantages as stated below. Price, \$5 each.

Bass Note Amplification —at last!

AS THE world's oldest and largest exclusive transformer builders, we have led for years in extending the amplifying range of transformers to lower and lower frequencies. In the Autoformer we have finally perfected an instrument capable of (1) giving full amplification of those bass notes hitherto largely "lost"; (2) greater clarity on all signals; (3) improved reception of distant programs; (4) better volume control. Autoformer amplification is for those who seek the finest reproduction of programs to be had. It may be used with any set in place of the regular audio transformer hook-up. Full directions, with diagrams, supplied with each Autoformer. Dealers everywhere.

Write for Autoformer Hook-up Bulletin.
THORDARSON ELECTRIC MANUFACTURING CO
WORLD'S OLDEST AND LARGEST EXCLUSIVE TRANSFORMER MAKERS
Chicago, U.S.A.



All Frequency Amplifier

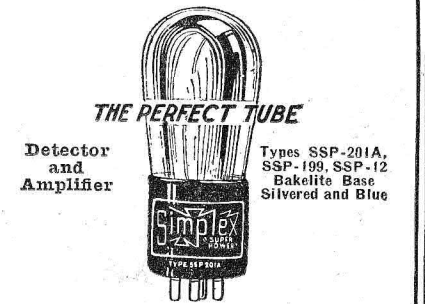

Detector and Amplifier

THE PERFECT TUBE

Types SSP-201A, SSP-199, SSP-12
Bakelite Base
Silvered and Blue



THE ELIXIR OF Set LIFE

JUST as the heart is the most vital organ of the human body—the tube is the most vital part of the radio set. The Simplex Super Power Tube performs its function in the radio set with the same sensitiveness, accuracy and regularity as a healthy heart in the human body.

Rejuvenate your set with the Simplex Super Power tubes, they mean longer life and better reception.

PRICE

Silvered tube \$2.00
Blue tube 2.50

GUARANTEE: Your dealer is authorized to exchange or return money for any defective tube within ten days.

Titania Manufacturing Company
makers of the
"SIMPLEX SUPER POWER" RADIO TUBES
105 West 40th Street, New York City

and slightly in front of the P terminal of the socket between transformers. Take off these three pieces of apparatus and drill holes at the spots just marked.

Now with the sub base in front of you and the front edge nearest you, mount the Thorola C on the two holes at the left end with G and GN to the right; the first radio frequency amplifier socket comes next with P and G at the rear; then Thorola T-1 with G and A to the right; then another socket with P and G to the rear; next comes Thorola T-2 with G and A to the right; then the detector socket with P and G at the rear; then the second audio frequency amplifier socket with P and G to the right. These units are all in a straight line across the panel. The three instruments previously mounted and taken off can now be put on again. The Bradleyleak is mounted between Thorola T-2 and the socket to its right; the Bradleyleak terminals and condenser go to the right. It will be necessary to use two 4-36 machine screws one inch long for this. The Amperite units are mounted, each with a single flat head 6-32 machine screw, in the two holes in front of the detector socket.

The antenna and ground binding posts go in the two holes at the rear left corner of the sub base, while the other seven go in the seven holes about midway the length of the panel near the rear edge. Insert them, from left to right, plus 90, plus 45, minus B, plus A, minus A, plus C and minus C.

It will be noted from careful examination of figure 7 that the two sockets between the Thorola coils, and the one to the right of Thorola T-2, are raised above the sub base about 1/4 inch. The reader can do this or not, as he pleases. The writer slipped binding post nuts over (Continued on page 22)

The Wilson "B" Radiopower Unit

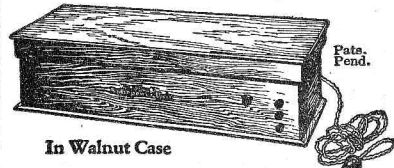

In Walnut Case

Operates from light socket. Supplies the uniform voltage necessary for perfect reception. Absolutely noiseless. Guaranteed not to set up the slightest hum.

No acid to spill. No moving parts to get out of order. Requires no attention. As easy to operate as switching on a light. Convenient and dependable. The least expensive plate current supply because of its long life. In handsome walnut case. Price complete, \$35. Your dealer can supply you.

The Andrews Paddlewheel-Coil

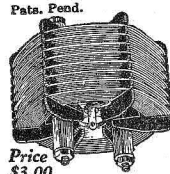

Price \$3.00

Improves tone quality. Increases selectivity, range and volume. Losses are negligible. Has exceptionally high ratio of inductance to resistance with minimum distributed capacity.

Used in well-known receivers such as the Deresadyne and Buckingham. Can be used in any standard hook-up. Ask your dealer for blue-prints of circuits employing this coil.

Our Technical Dept. will answer inquiries.

Duo-Spiral Folding Loop

Highly directional and very selective. Reduces static and helps to cut out interfering stations.

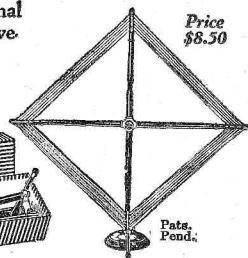

Price \$8.50

Handsomely finished in silver and mahogany. Easily portable. Has long handle and graduated dial. A special model for every circuit.

See these standard units at your dealer's or write for complete information.

Radio Units Inc.
Maywood, Illinois
1306 First Avenue
Perkins Elect. Ltd., Montreal, Toronto, Winnipeg

Questions and Answers

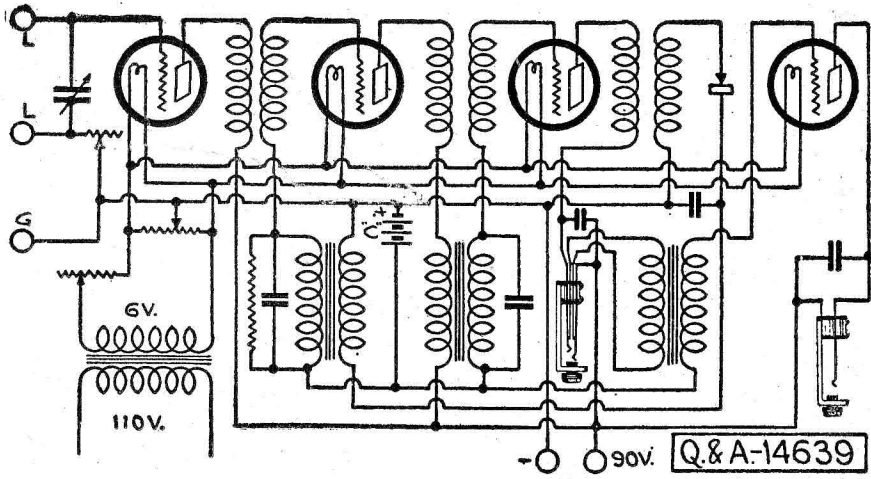

110 Volts on Acme Reflex
(14639) BKR, Cleveland, O.
I have a four tube Acme reflex receiver that has been giving me good service for some months. Your recent article on the use of 110 volts lighting current for the filament supply looks good to me but I cannot work out the circuit for applying it to my set. Will you please set me right on this? The diagram of my set is enclosed.

A.—While it may be subject to a few changes, we believe the diagram shown above will be correct for combining your set with the Cope unit described. The chief change lies in the potentiometer used to get the correct bias on the grid of the first tube. Since we no longer have a D. C. line with 6 volts, this potentiometer cannot be put across the filament circuit for securing grid bias.

It is now in the filament return of the first grid circuit where it introduces losses sufficient to keep the first tube

from oscillating. Its use here may broaden the tuning slightly but not a great deal. The key wire to which all grids return and to which the negative B is connected may or may not have to be grounded but we believe it will, as shown.

B Battery Eliminators
(14591) GG, Johnsonburg, Pa.
I would like to have your opinion of B battery eliminators and if there is one on

Better Edison Elements 7½c pair. Sample 10c. Chapelle, Woodburn, Oregon.

Long Distance Radio \$2.95. Lambert's newest crystal success. No tubes. No batteries. No grief. Always ready. Works 600 miles. Fully guaranteed. We pay postage. Order direct from this ad. Leon Lambert, Wichita, Kansas.

Station after station pops in as you turn one dial. More selective, distance and volume. Daytime service from distant stations. All say 'NOTHING EQUALS IT.' Tuner with dial \$10
F. C. BRADLEY, Union, Miss.

the market that you would advise me to buy.

A.—You can, we are sure, buy with confidence the Balkite, Freshman, Gould, Philco or Cooper. The last named two also make combinations of A and B eliminators.

"TRAVELER" RECEIVER

(Continued from page 21)

the mounting screws on those sockets, between the sockets and the sub base to raise them and reduce any dielectric absorption of energy by the sub base from the socket springs, and reduce the tendency of dielectric placed close to them to cause greater capacity between plate and grid springs.

(The wiring of the sub base and the

25 RADIO FREE STAMPS

With World Radio Stamp Album and Log. Contains ruled spaces for stamps of stations in U. S., Canada, Europe, etc. Stick stamps in proper spaces as stations are heard. Also contains convenient Log and complete list of stations, call letters, wave lengths, etc. Send \$5c for Album and get 25 genuine radio stamps. FREE. Order NOW.

WORLD TRADING CO., Dept. 9417, 366 Wrigley Bldg., Chicago

AMBASSADOR
LONDON
SEND FOR FREE 4 PAGE COIL FOLDER
COILS HAVE RECEIVED ROME AND LONDON BOTH VERIFIED
AMBASSADOR SALES CO., 108 Greenwich St., N.Y.

COMPLETE 500 WATT TRANSMITTER FOR SALE CHEAP

A transmitter favorably known from Coast to Coast and from Alaska to South America. Built by one of the country's foremost Radio Engineers.

Southern Equipment Company
San Antonio, Texas

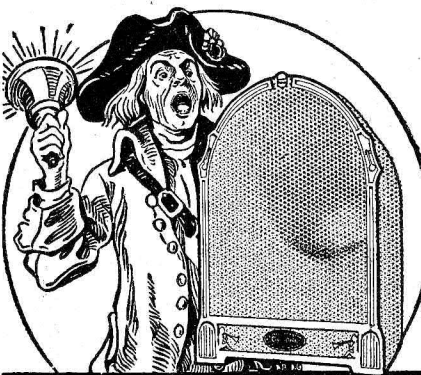

The TOWN CRIER

Radio's Most Beautiful Speaker

WRITE today for illustrated description in colors of this beautiful instrument—"The Speaker with the Voice that Thrills." You will be delighted with the artistic stippled finish and the gorgeous colors of the Town Crier models in Green and Golden Polychrome. Ask your Dealer to show you a Town Crier—you will recognize its surpassing excellence instantly.

PRICE
\$17.50 West of the Rockies \$18.50
GALE RADIO LABS.
2513 Irving Park Blvd. CHICAGO

wiring between the sub base and front panel will be taken up next week by Mr. Ryan. This will complete the construction, and the fourth article will contain adjusting and tuning instructions.—Editor's Note.)

Telegraphy—Both Morse and Wireless taught thoroughly. Big salaries. Wonderful opportunities. Expenses low; chance to earn part. School established fifty years. Catalog free. Dodge's Institute, Sixth St., Valparaiso, Ind.

RADIO EXPERTS EARN BIG MONEY
Thousands of big pay opportunities open to the radio trained man. Success easily won in the fastest growing industry of all time. From land and sea comes the urgent call for men who can construct, install, operate, repair, maintain and sell radio equipment.
CASH for Your Spare Time!
Take orders from your neighbors for radio sets. Get big fees for your services and advice. Home study qualifies you—short course, low cost, easy terms, money back guarantee.
FREE Wonderful tube receiving set of latest design. Range over 1000 miles. Write today for FREE copy of "Radio Facts."
A. G. MOHAUPT, Radio Engineer
RADIO ASSOCIATION OF AMERICA
4513 Ravenswood Ave., Dept. RD 1 Chicago



It's OUT—Complete everlasting ready to run non-acid, non-sulphating 22½-volt rechargeable "B" storage battery, \$2.95. Includes chemical. Does not lose its charge standing idle. Special 2-22½ volts (45 volts) \$5.25; 90 volts \$10.00. 112½ volts \$12.50; 135 volts \$14.75; 157½ volts \$16.80. Nearly 3 years sold on a non-red tape, 30-day trial offer, with complete refund if not thoroughly satisfied. Further guaranteed 2 years. Knock-down kits at still greater savings. Complete ready to run "B" battery charger \$2.75. Sample cell 35c. Order direct—send no money—simply pay expressman its cost on delivery, or write for my free literature, testimonials and guarantee. Same day shipments. My large 36-page radio goods catalogue 10c. B. D. Smith, 31 Washington Ave., Danbury, Conn.

Make \$100 WEEKLY in spare time. Sell what the public wants—long distance radio receiving sets. Two sales weekly pays \$100 profit. No big investment, no canvassing. Sharpe of Colorado made \$955 in one month. Representatives wanted at once. This plan is sweeping the country—write today before your county is gone. OZARKA, Inc., 128D West Austin Ave., Chicago.

Wanted—
Commercial operator for 100-watt Radio station. In town of 100,000. Regular or part time. Radio department sales work in connection with the operating. Steady employment year round. Good salary. Pleasant place to work. Advise fully about yourself in first letter.
X. Y. Z., CARE OF RADIO DIGEST
510 North Dearborn St.
CHICAGO, ILL.

Any Radio Map a Month Old Is Out of Date

Unless It Has a Monthly Supplemental Service THE AIR-LINE RADIO MAP and LOG With Patented Movable Mile Scale Has This Service

Lists stations by call letters, also by wave lengths. UNIQUE BROADCASTING SCHEDULE. LOG shows location; difference in time; power, meters and kilocycles; spaces to list dial settings; time heard, distance, signal strength. Whether you use outdoor aerial or loop, direction of loop, phones or loud speaker.

An Individual Log for Every Station
If you do not find this the most complete serviceable RADIO MAP and LOG published, we will refund your money.
Price 50 Cents

At your dealers, or sent postpaid. Dealers and Jobbers Write at Once.
MULTIVIDER CO. ST. JOHN and ASKEW
KANSAS CITY, MO.

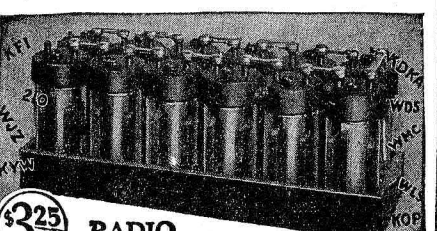

RADIO Storage "B" Battery

32 Cells 24 Volts
Lasts Indefinitely—Pays for Itself

Economy and performance unheard of before. Recharged at a negligible cost. Approved and listed as Standard by leading Radio Authorities, including Pop. Radio Laboratories, Pop. Sci. Inst. Standards, Radio News Lab. Letfax, Inc., and other important institutions. Equipped with Solid Rubber Case, an insurance against acid and leakage. Extra heavy glass jars. Heavy, rugged plates. Order yours today!

SEND NO MONEY Just state number of batteries wanted and we will ship day order is received. Extra Offers: 4 batteries in series (96 volts), \$12.75. Pay expressman after examining batteries. 6 per cent discount for cash with order. Mail your order now!

WORLD BATTERY COMPANY
1219 So. Wabash Ave., Dept. 76 Chicago, Ill.
Makers of the Famous World Radio "A" Storage Battery
Prices: 6-volt, 100 Amp. \$11.25; 20 Amp. \$13.25; 140 Amp. \$14.00.
All equipped with Solid Rubber Case.

World STORAGE BATTERIES
Set your Radio Dials at 210 meters for the new 1000 watt World Storage Battery Station, WSBC, Chicago. Watch for announcements.
KOA-WEAF-WGN-WJZ-KHL-KGO-KFJ-WJW

Manufacturers! A Service You Need

A director of sales and advertising. A personal producer with the following credentials. Wide experience with manufacturers' problems and how met, gained through manufacturing, advertising agency and publishing training. Ability to create sales plans, that sell goods, knowledge of how to coordinate advertising and sales departments to produce maximum results. Thoroughly versed in radio, publisher and agency service. Willing to demonstrate ability. Will accept modest salary and share of increased profits. Only well financed proposition considered. Manufacturers invited to correspond with Box 200, care of Radio Digest, 247 Park avenue, New York, N. Y.

Jones Cabelug
Completing Cables and Solenoid Leads Little Brother to the Tune
MULTIVIDER
4 Foot \$100
8 Foot \$125
HOWARD B. JONES 618 S. CANAL ST. CHICAGO, ILL.

Announcing a new and very practical battery connector, the Jones Cabelug consists of a five wire coded cable, anchored to an insulated block, cable ends projecting from the block serving as terminals for the set leads. The block is permanently mounted on the panel or sub-panel, allowing the set builder to complete his wiring arrangement, and leaving nothing to connect but the battery ends. No binding posts required.
HOWARD B. JONES
618 S. Canal St. CHICAGO

Wow that Static!
KILL STATIC
Enjoy clear reception of all stations without annoyance. The Static Eliminator—the newest and most startling thing in Radio—cuts out practically all static without loss of volume.
And in addition it will help increase selectivity, tune out local stations, sharpen signals, remove noises, lessen interference and stop re-radiation!
Use it with any receiving set—hook it up in less than a minute and enjoy perfect reception unmarred by static.
\$1.00 Postpaid
Mail Your Order Today. Satisfaction Guaranteed. Money refunded at once, if returned within 5 days.
Static Eliminator Company
610 United Bank Bldg. CINCINNATI, OHIO
Not a Bit of Static Now!



Tower

Little Spitfire Loud Speaker

\$4.95

Equipped with adjustable unit

Covers EVERY Chromatic in the Entire Scale

Equipped with an attractive fibre horn with 8½" bell, the Little Spitfire is light in weight though producing a volume equal to the highest priced Speakers. Horn and base are finished in black crystalline lacquer with nickel plated ferrule. Hear the Little Spitfire today! You will be agreeably surprised at its pure, clear tone and attractive appearance.

Wherever there are ears that hear there is a Tower Quality Product to Fit your Taste and Pocketbook.

ON SALE AT ALL GOOD DEALERS FROM COAST TO COAST

**TOWER MFG. CORPORATION
98 BROOKLINE AVE. BOSTON, MASS.**

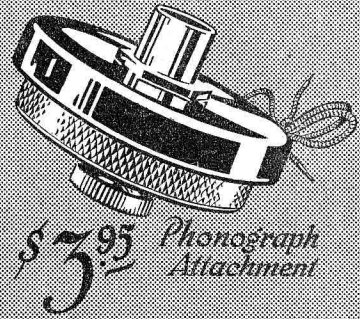
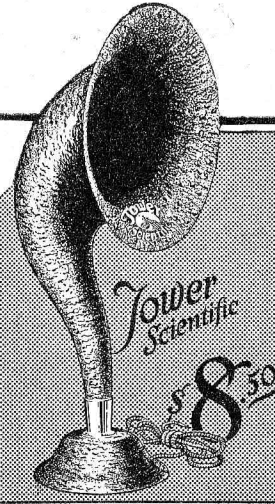

WORLD'S GREATEST LOUDSPEAKER VALUES